

Floating Bed Frame

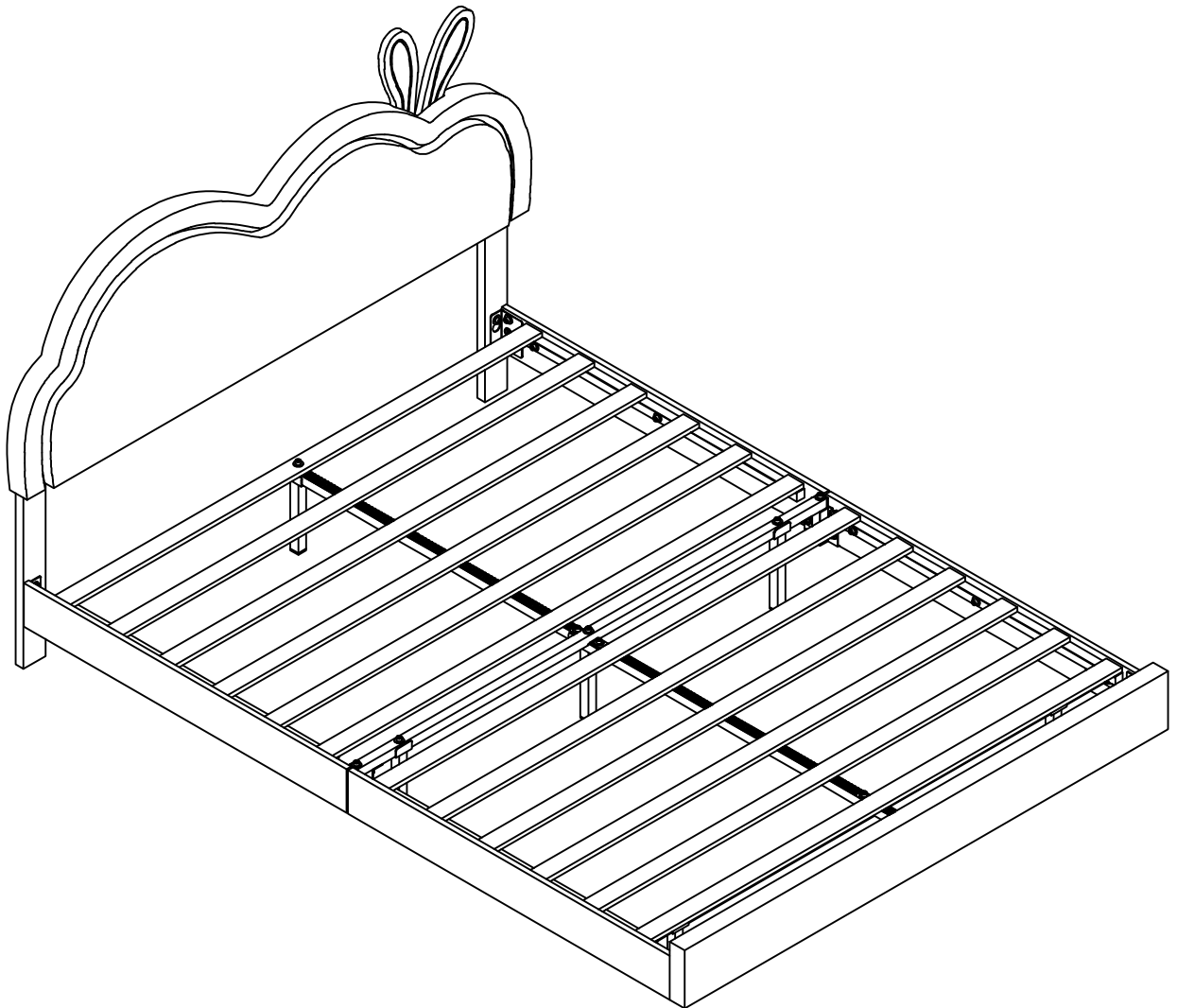

Friendly Customer Service
Satisfaction Guarantees: Any problems with assembly,
quality, or return, please feel free to contact us directly.

Contact us
Phone: +1 (901) 347-2181 (US) Mon-Fri 9am - 5pm (PST)
E-Mail: support@jocisland.com (Get efficient feedback within 12 hours)

! IMPORTANT

Please follow the instruction manuals and use a pad to protect the product during your assembly.

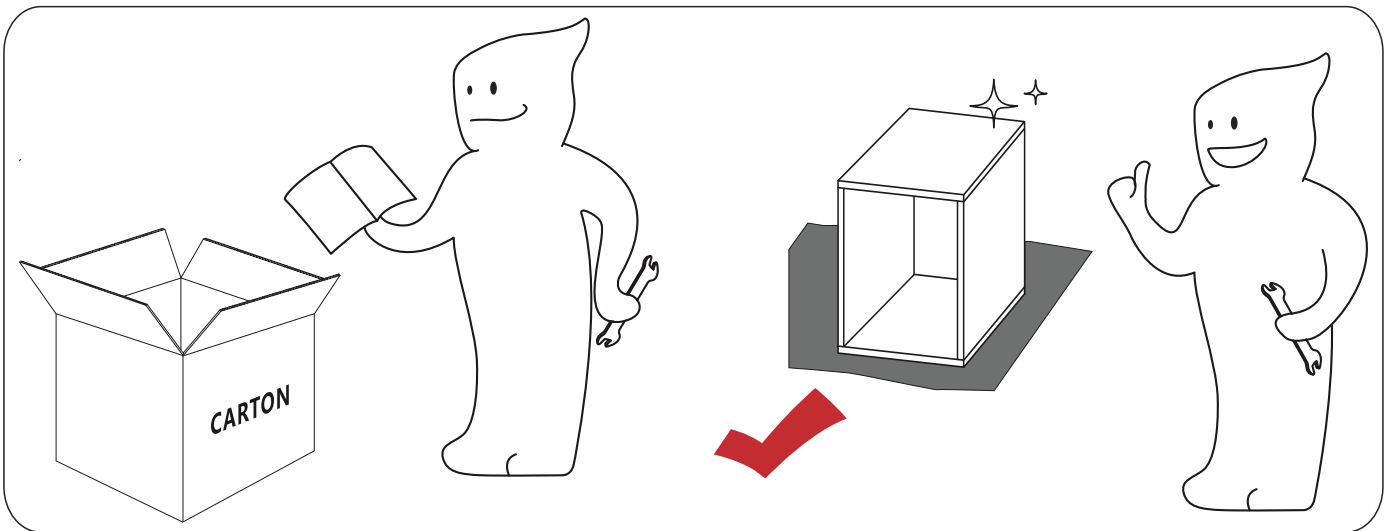
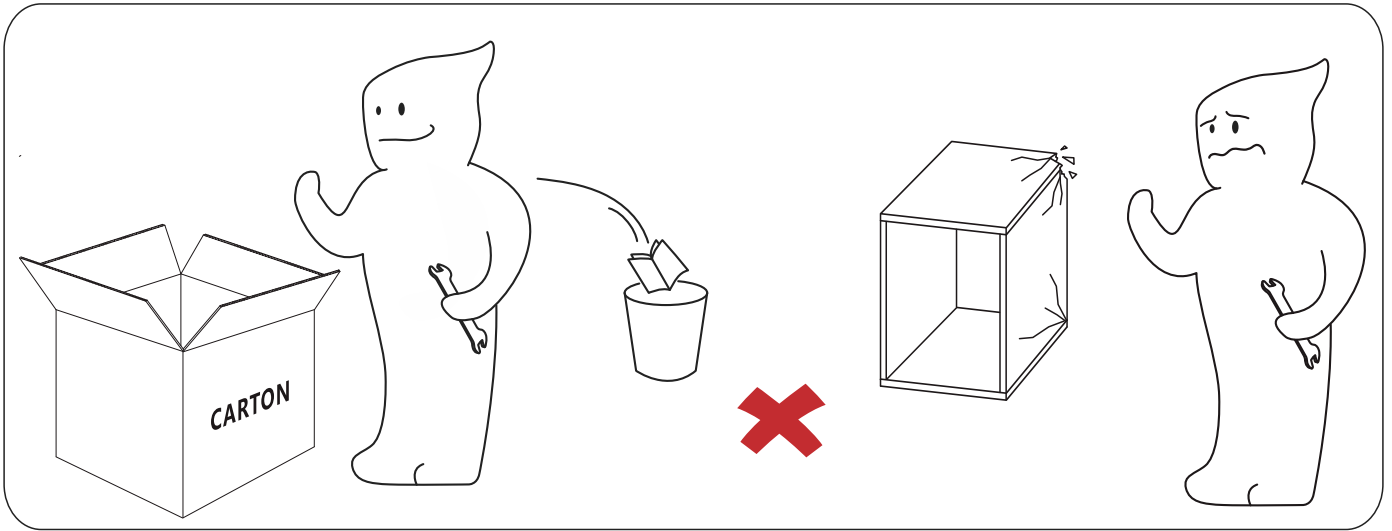

Note:

1. Should be assembled on flat ground to keep balance.
2. Before completing the installation, do not tighten the screws.





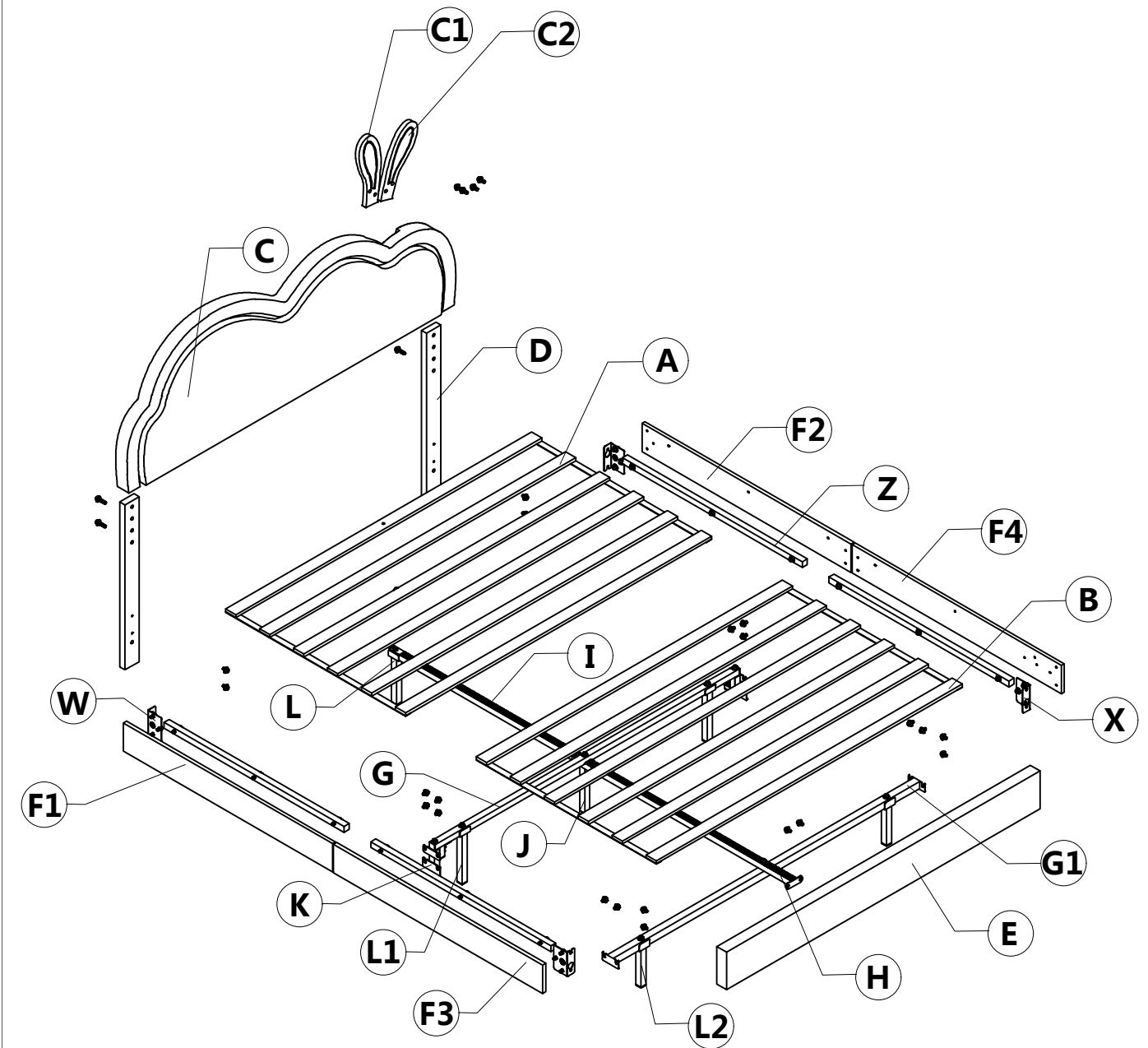

For easier and better assembly, **2** or more adults are required.

ASSEMBLY INSTRUCTIONS

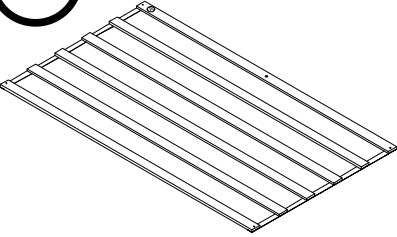
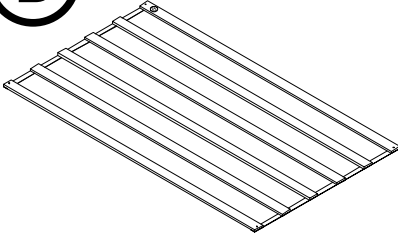
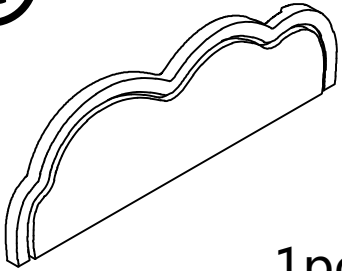

BED FRAME PARTS LIST

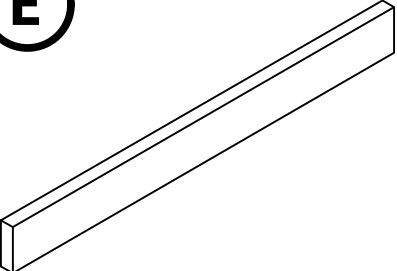
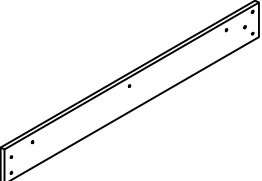
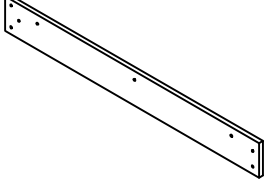
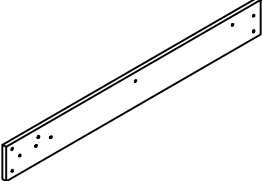
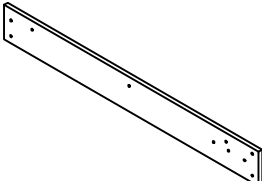
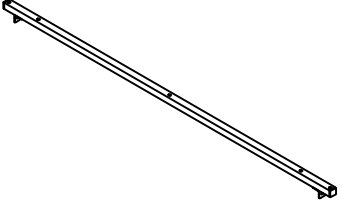
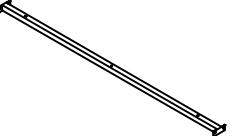
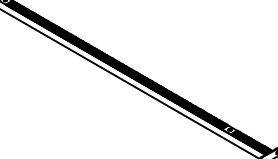
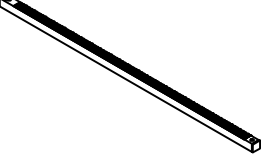
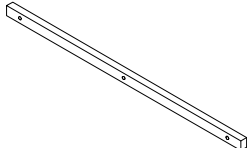
<p>(A)</p>  <p>1pc</p>	<p>(B)</p>  <p>1pc</p>	<p>(C)</p>  <p>1pc</p>	
<p>(C1)</p>  <p>1pc</p>	<p>(C2)</p>  <p>1pc</p>	<p>(D)</p>  <p>2pcs</p>	
<p>(E)</p>  <p>1pc</p>	<p>(F1)</p>  <p>1pc</p>	<p>(F2)</p>  <p>1pc</p>	
<p>(F3)</p>  <p>1pc</p>	<p>(F4)</p>  <p>1pc</p>	<p>(G)</p>  <p>1pc</p>	
<p>(G1)</p>  <p>1pc</p>	<p>(H)</p>  <p>1pc</p>	<p>(I)</p>  <p>1pc</p>	<p>(Z)</p>  <p>4pcs</p>

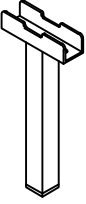
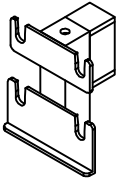
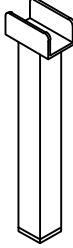
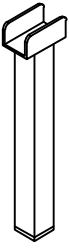
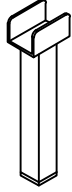
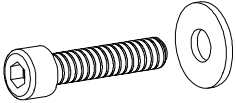
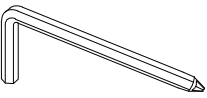
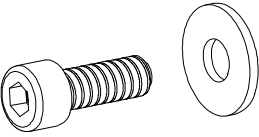
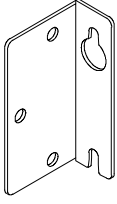
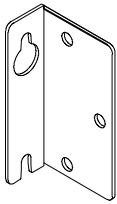
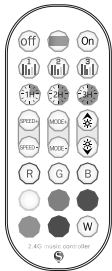
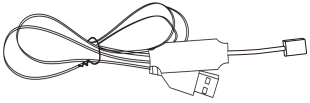
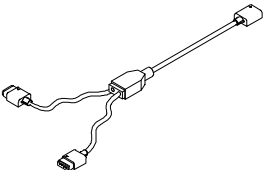
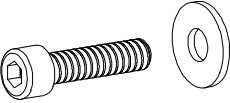

FITTING PARTS LIST

<p>(J)</p>  <p>1pc</p>	<p>(K)</p>  <p>2pcs</p>	<p>(L)</p>  <p>1pc</p>
<p>(L1)</p>  <p>2pcs</p>	<p>(L2)</p>  <p>2pcs</p>	<p>(N)</p>  <p>M8 X45mm 11pcs+1pc</p>
<p>(P)</p>  <p>M8 Spanner 1pc</p>	<p>(Q)</p>  <p>M8 X25mm 2pcs</p>	<p>(W)</p>  <p>2pcs</p>
<p>(X)</p>  <p>2pcs</p>	<p>(W1)</p>  <p>1pc</p>	<p>(X1)</p>  <p>1pc</p>
<p>(X2)</p>  <p>1pc</p>	<p>(Y)</p>  <p>M8 X40mm 20pcs+1pc</p>	

ASSEMBLY INSTRUCTIONS

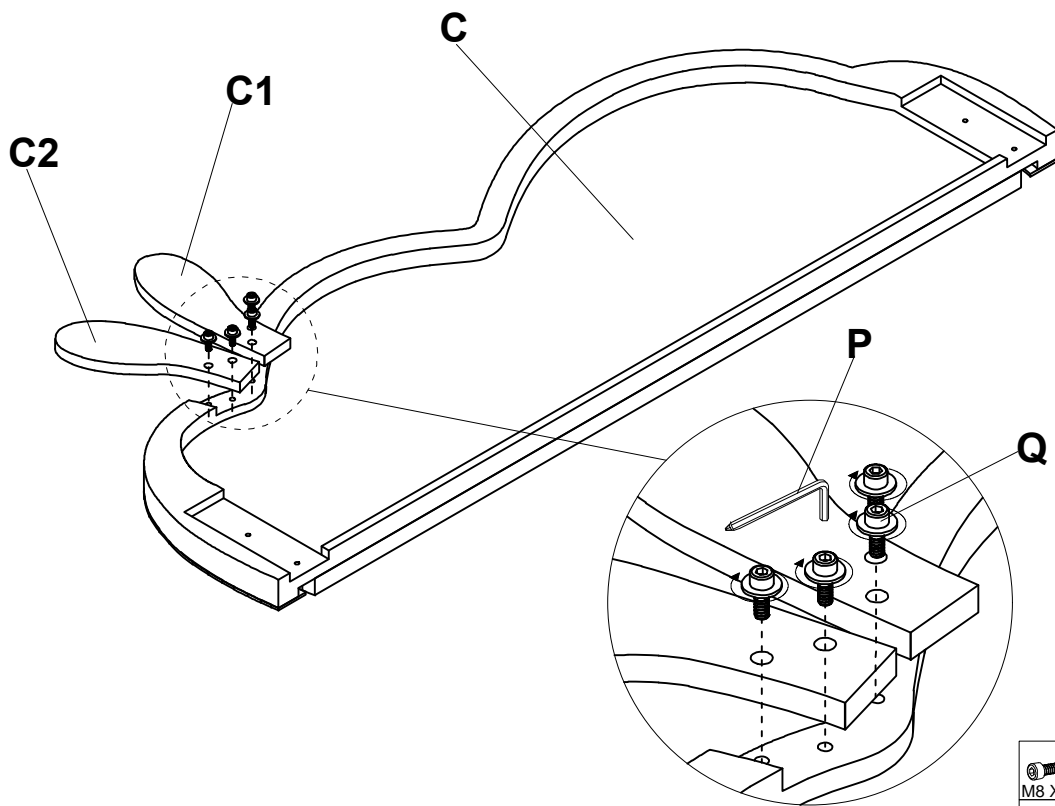
STEP 1



 M8 X40mm	Y x 4pcs
	P x 1pc

STEP 2

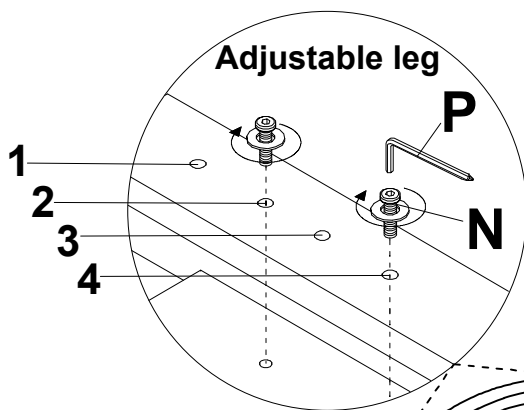

Plan A

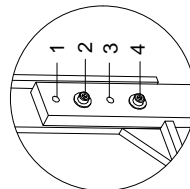

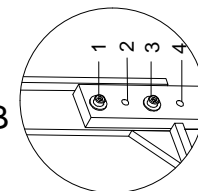

Fits a 10 inch thick mattress when attach screws to Hole 2 & Hole 4.

Plan B



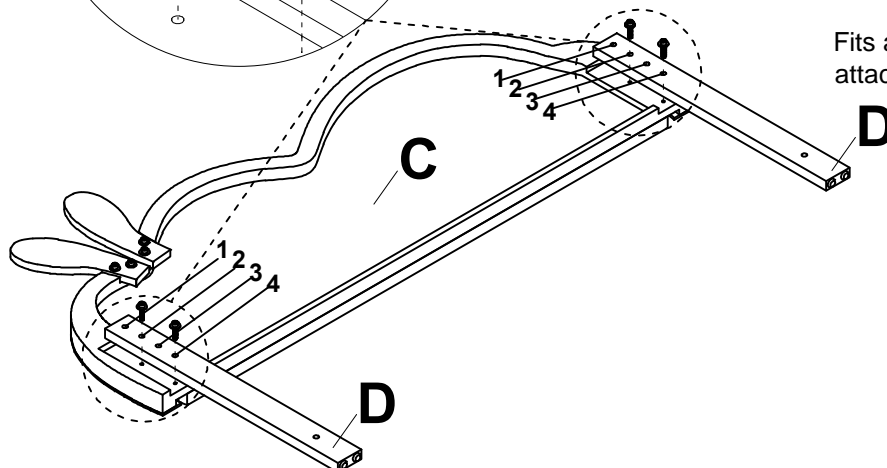

Fits a 12 inch thick mattress when attach screws to Hole 1 & Hole 3.



 M8 X40mm	Y x 4pcs
	P x 1pc

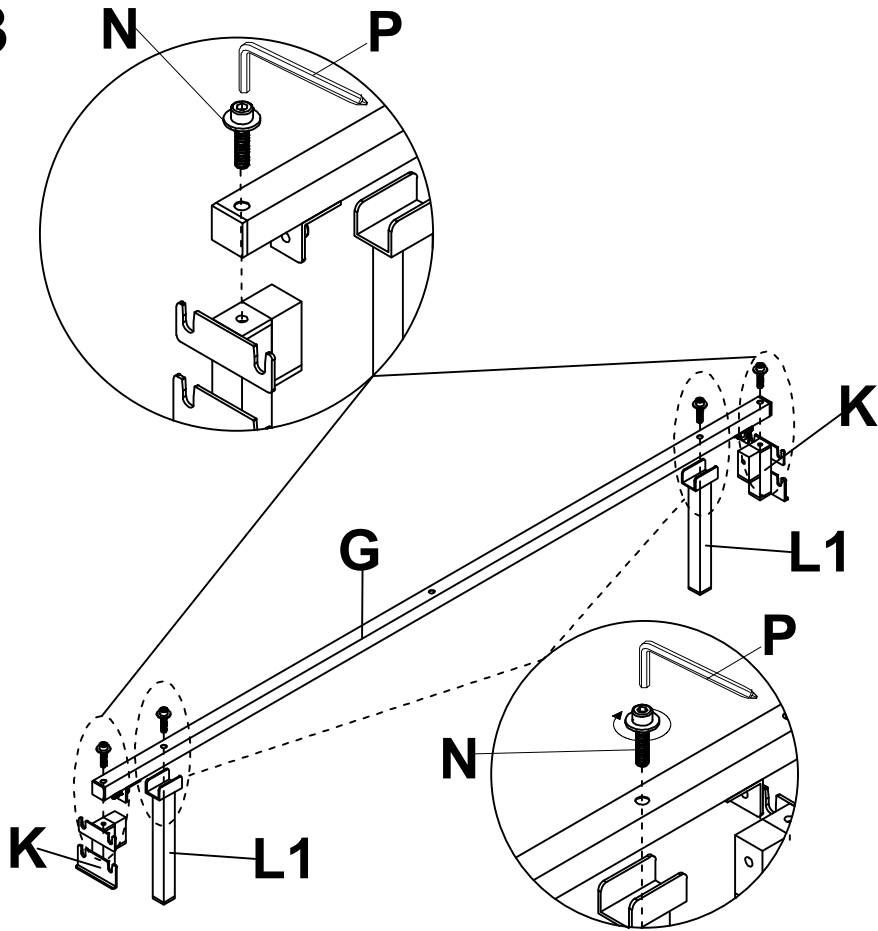

STEP 3



 M8 X45mm	N x 4pcs
	P x 1pc

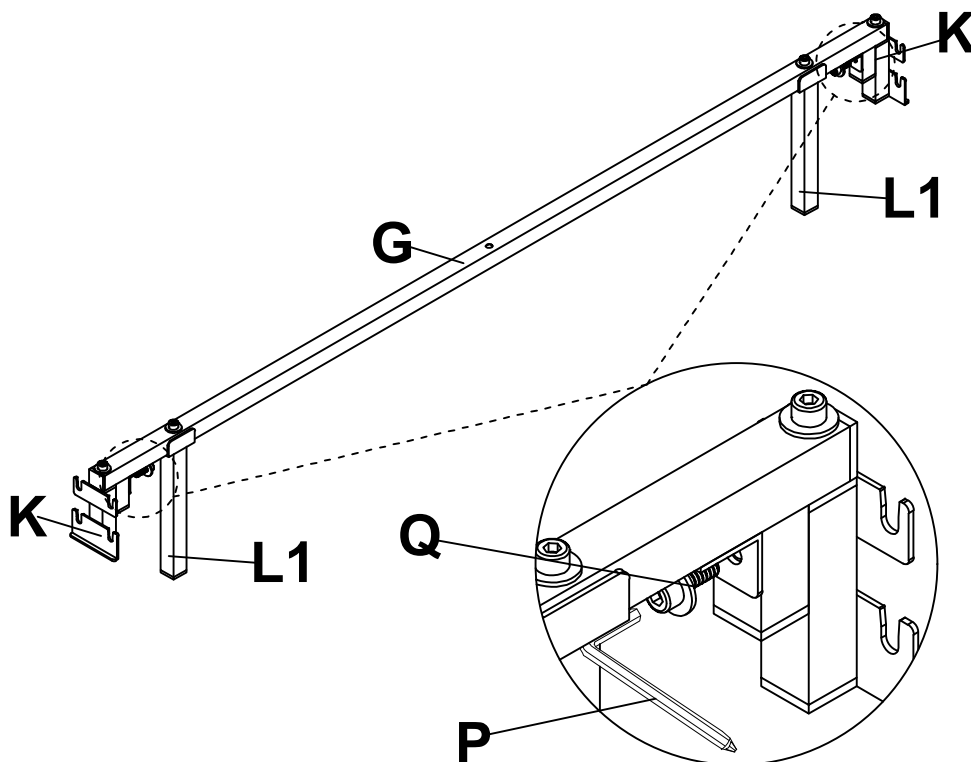

STEP 4

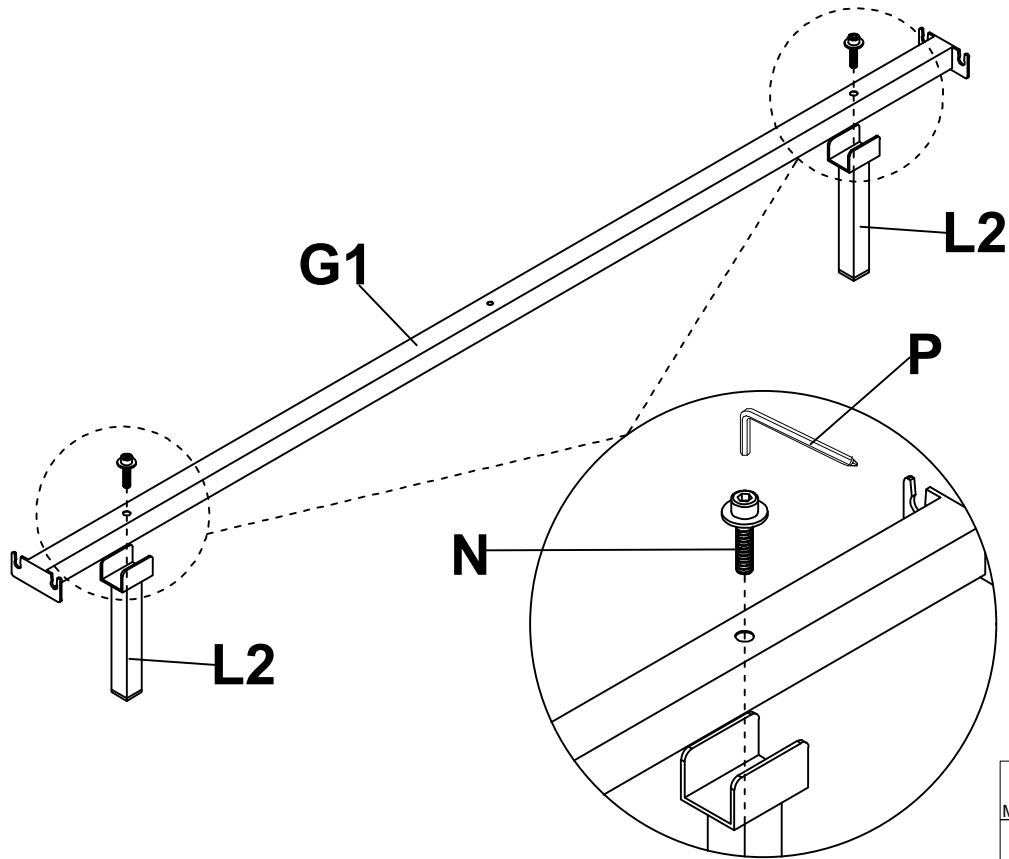

 M8 X25mm	Q x 2pcs
	P x 1pc

STEP 5





	N x 2pcs
M8 X45mm	
	P x 1pc

STEP 6

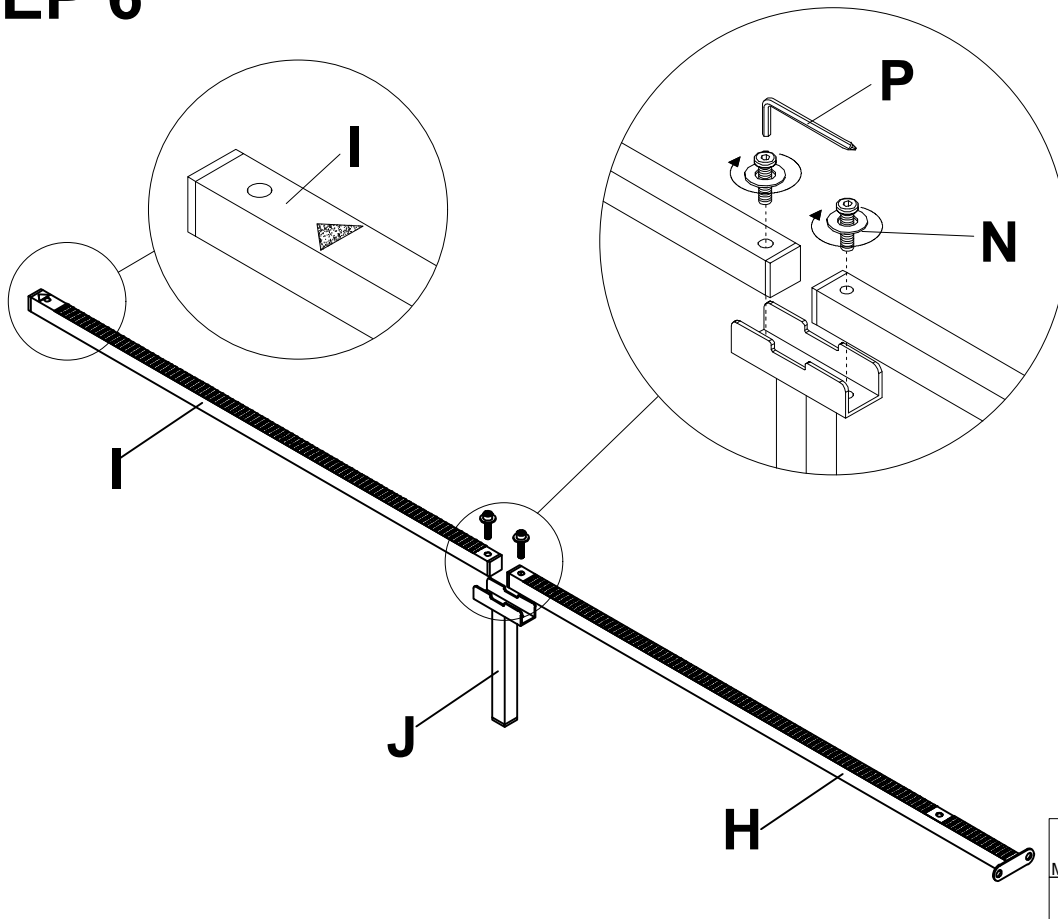

Noted that the red arrow is pointing towards the front.

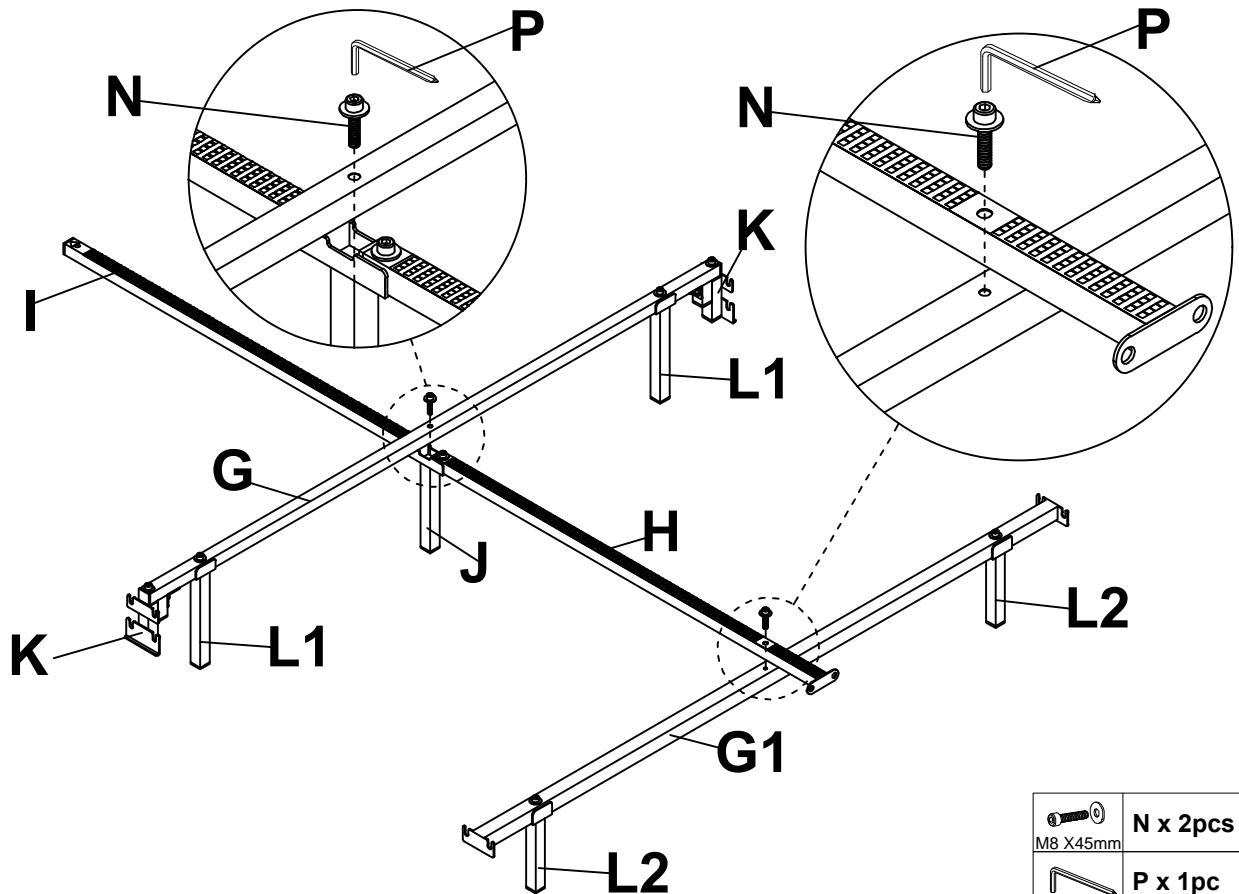

	N x 2pcs
M8 X45mm	
	P x 1pc

STEP 7





	N x 2pcs
	P x 1pc

STEP 8

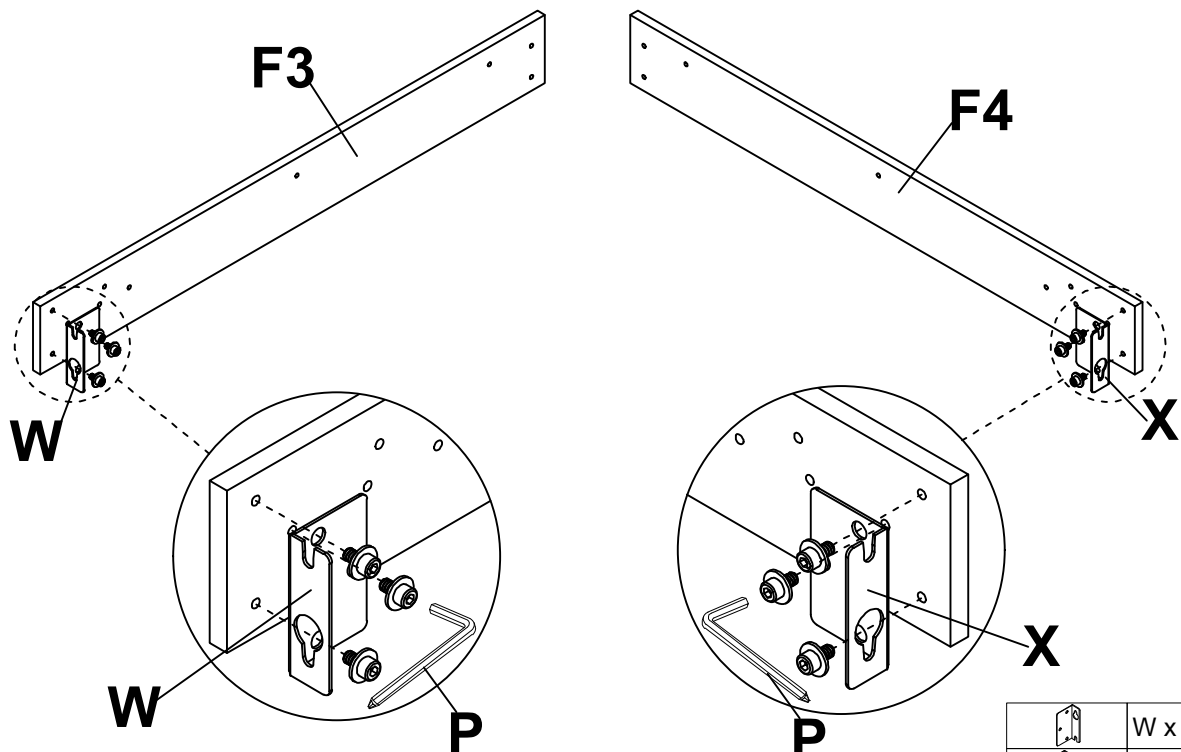
Remove the pre-screwed screws on the panel first, and using these screws to cross the holes on the bracket and tighten the inner screws to lock the bracket.
 Note: The installation direction is as shown in the picture.



	W x 1PC
	X x 1PC
	P x 1PC

STEP 9

Loosen the screw of side panel, then hang the bracket on and tighten the inner screws.

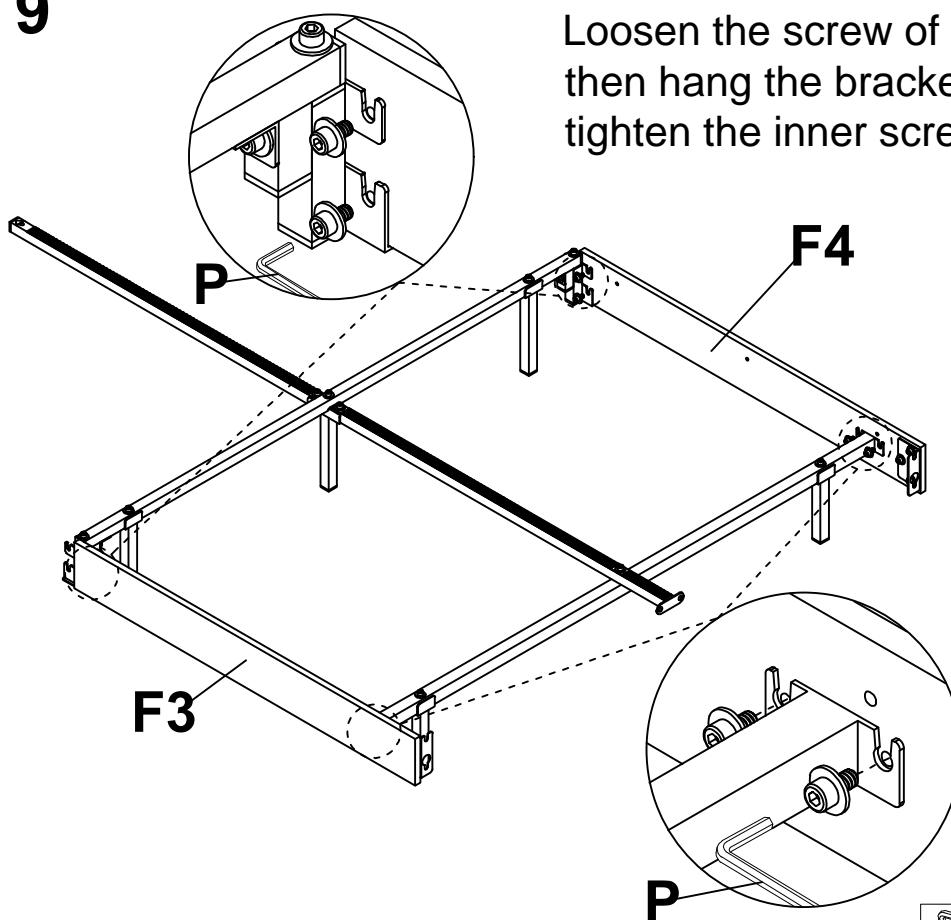



	P x 1PC
---	---------

STEP 10

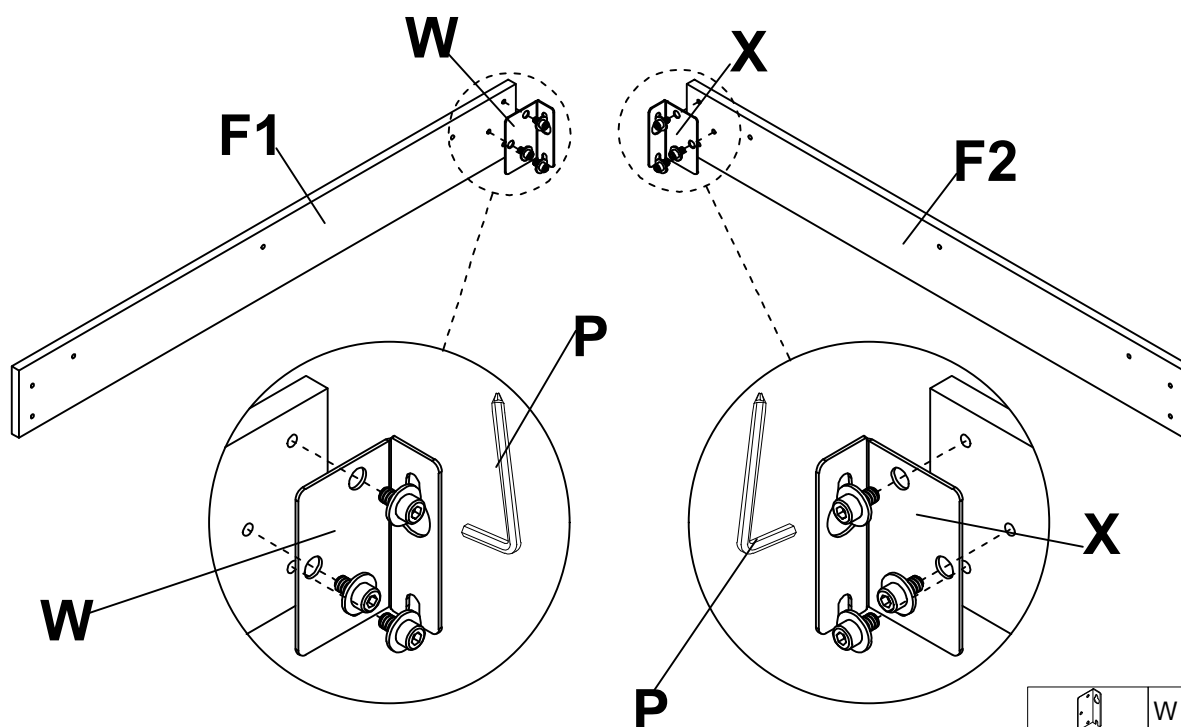
Remove the pre-screwed screws on the panel first, and using these screws to cross the holes on the bracket and tighten the inner screws to lock the bracket.
Note: The installation direction is as shown in the picture.



	W x 1PC
	X x 1PC
	P x 1PC

STEP 11

Loosen the screw of headboard side leg, then hang the bracket on and tighten the inner screws.

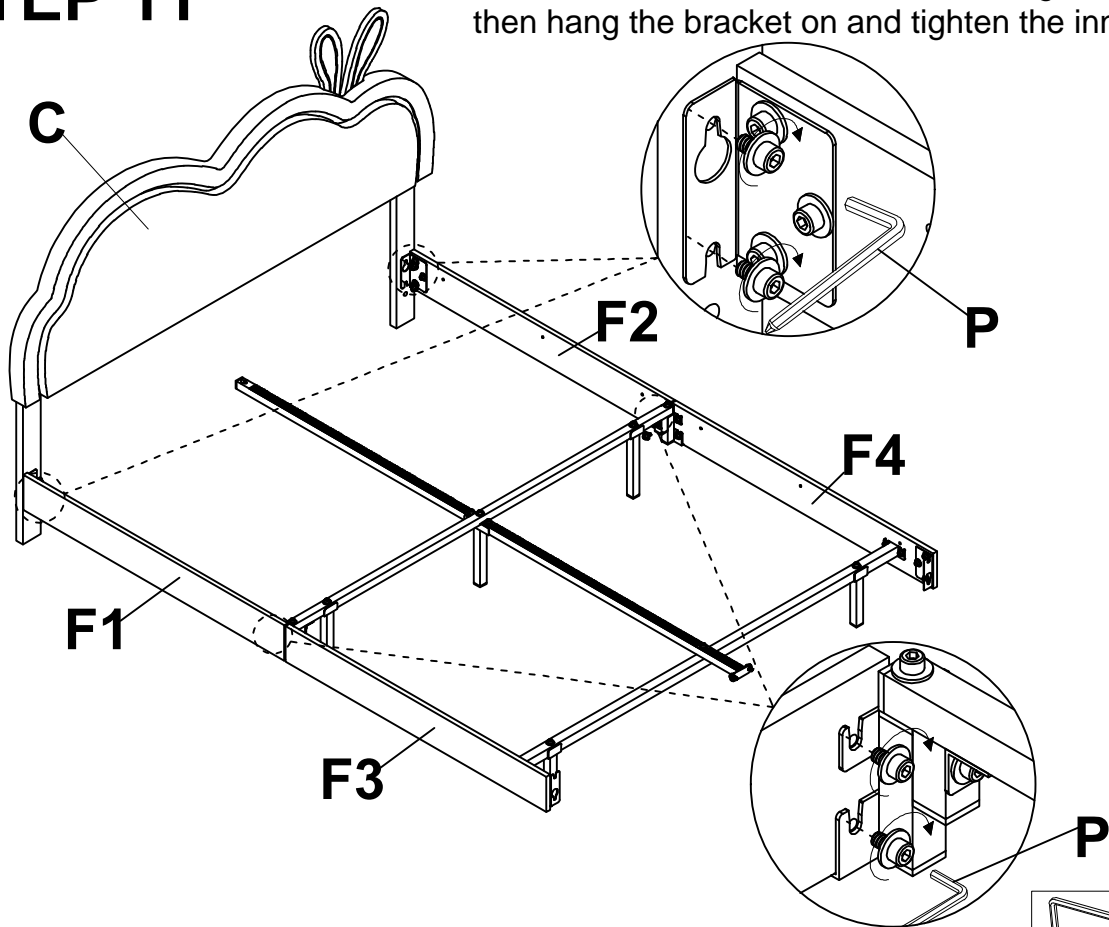

STEP 12

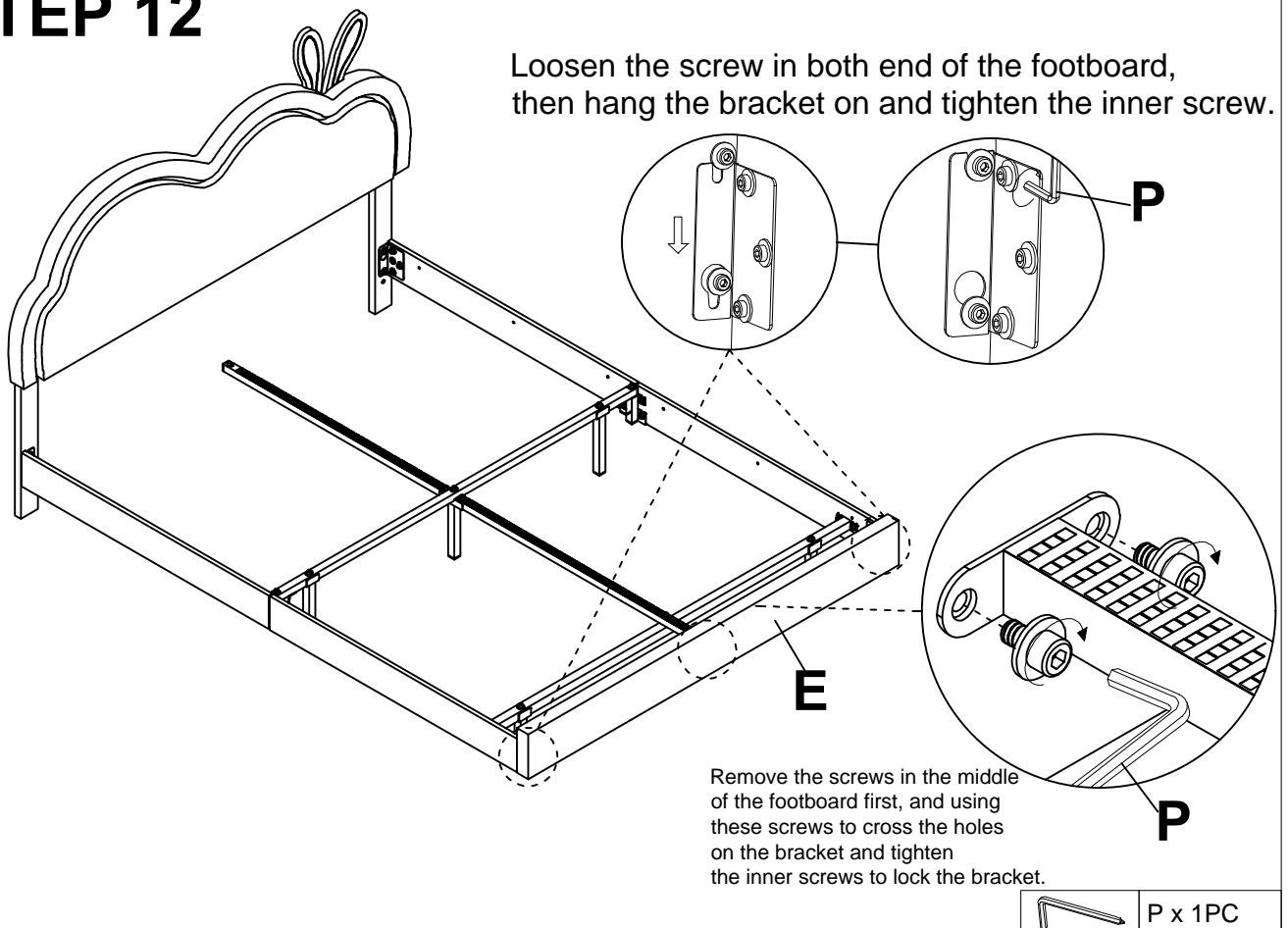

Loosen the screw in both end of the footboard, then hang the bracket on and tighten the inner screw.

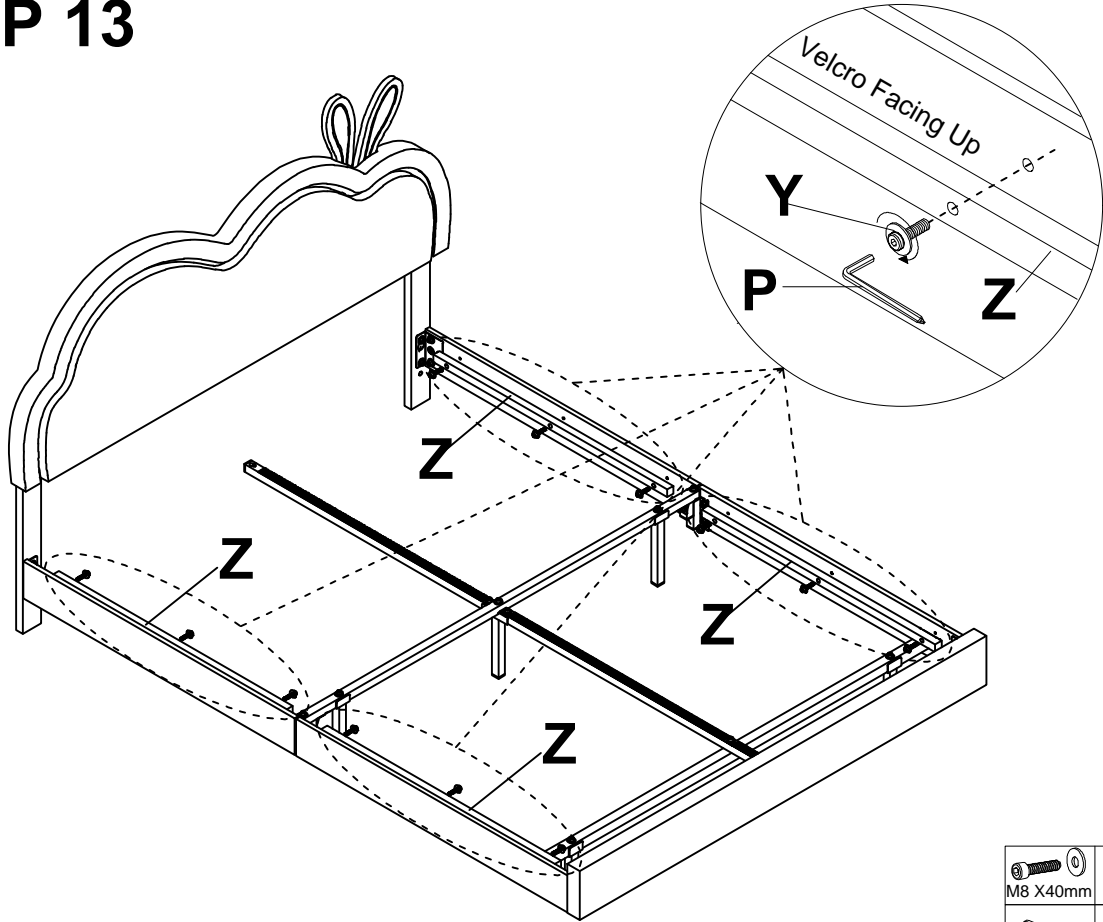

Remove the screws in the middle of the footboard first, and using these screws to cross the holes on the bracket and tighten the inner screws to lock the bracket.

STEP 13



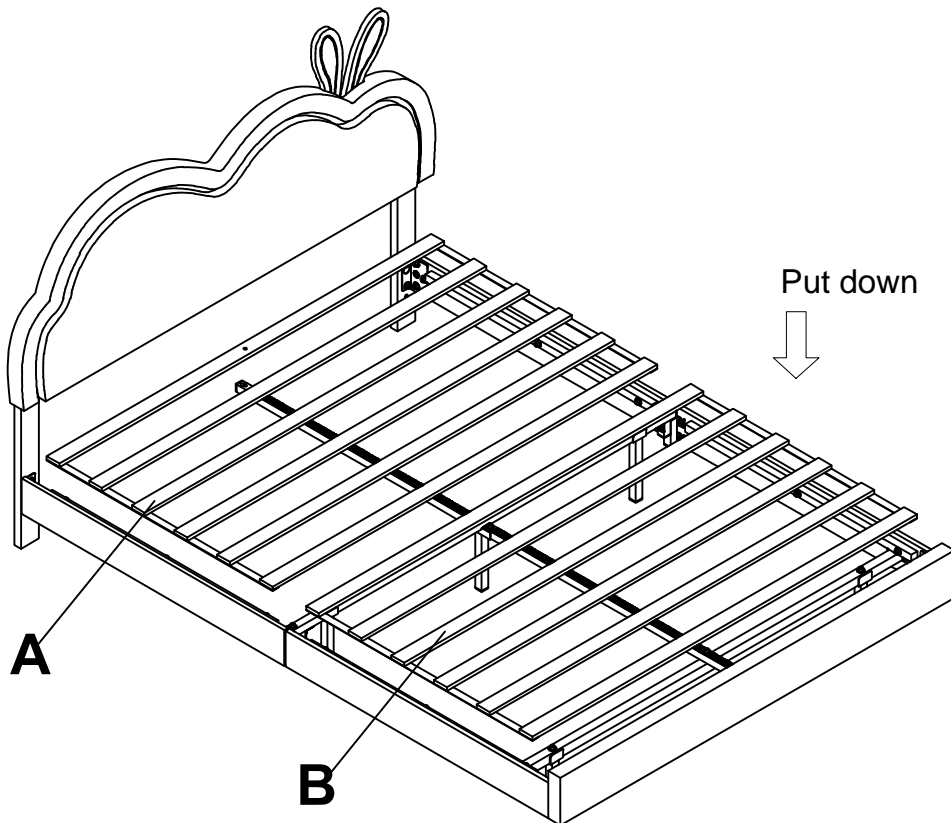

 M8 X40mm	Y x 12pcs
	P x 1pc

STEP 14

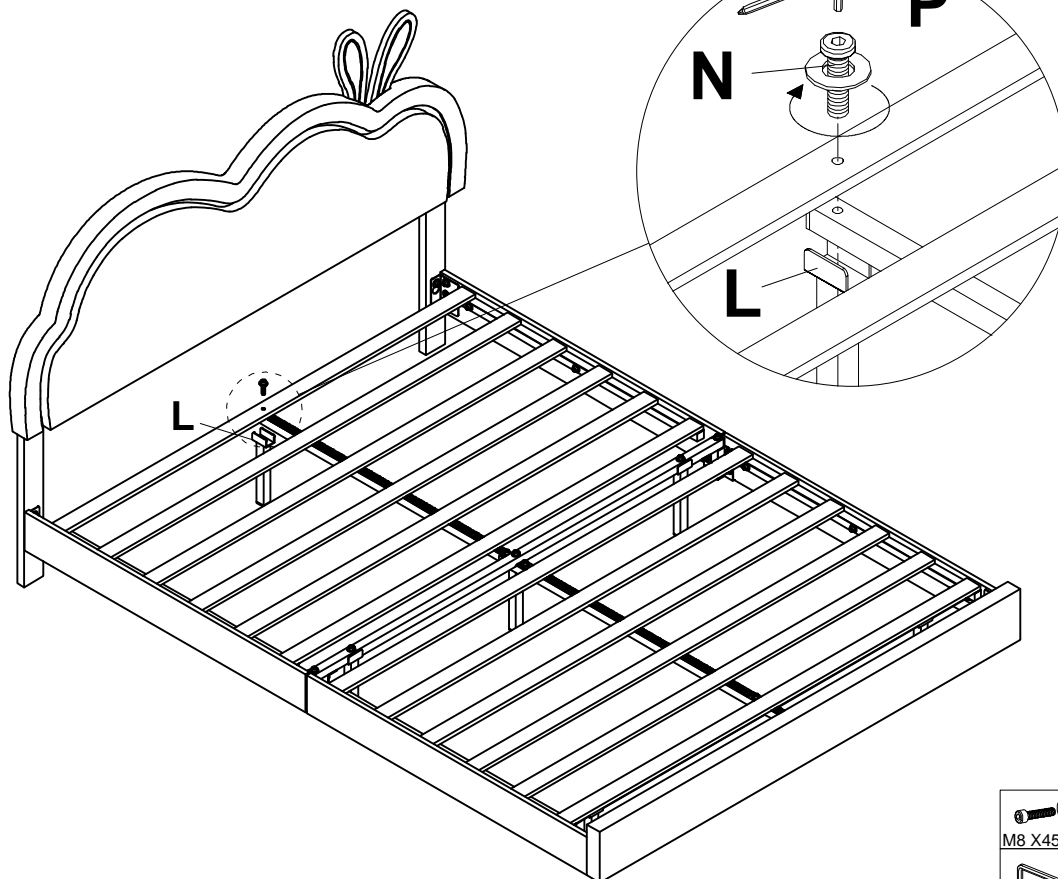

STEP 15



 M8 X45mm	N x 1pc
	P x 1pc

STEP 16

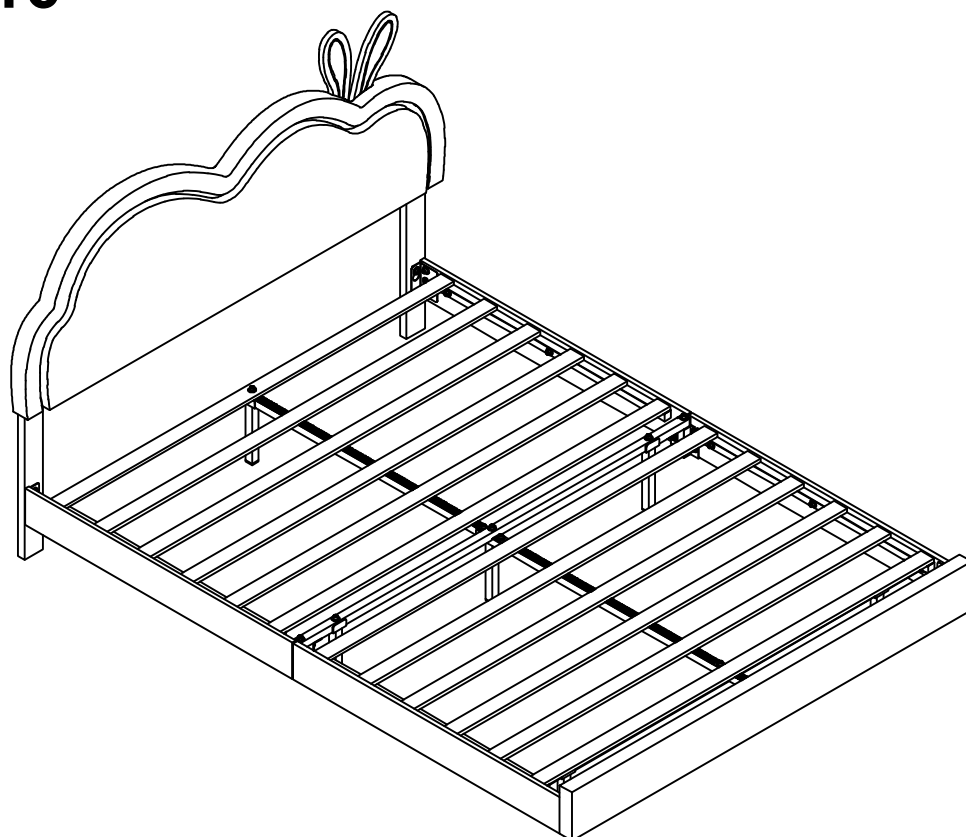

STEP 17

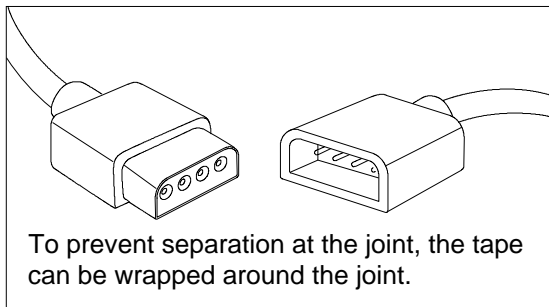

NOTE: The black part of the receiver (X1/X2) needs to be exposed to air in order to better control the LED light.

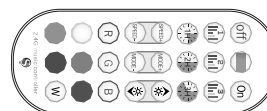

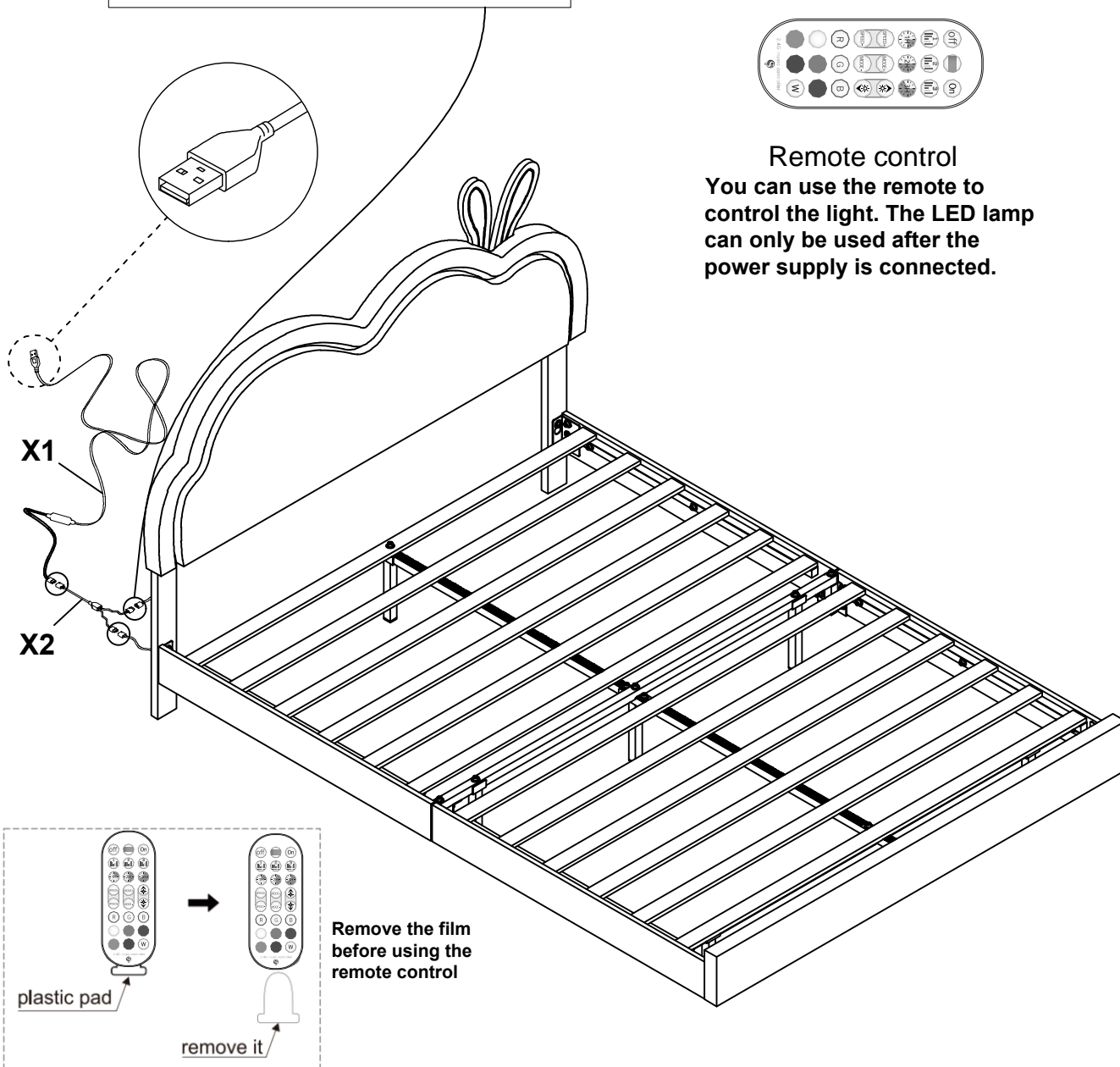

Remote control
You can use the remote to control the light. The LED lamp can only be used after the power supply is connected.

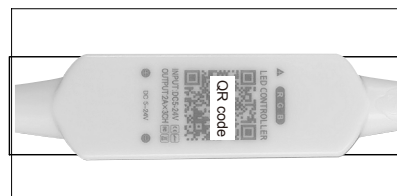

Please scan the QR code on the manual/controller and install the application.
Step1: Please make sure your phone has bluetooth enabled.
Step2: The LED light will automatically connect to the APP.



	X1 x 1pc
	X2 x 1pc

STEP 18

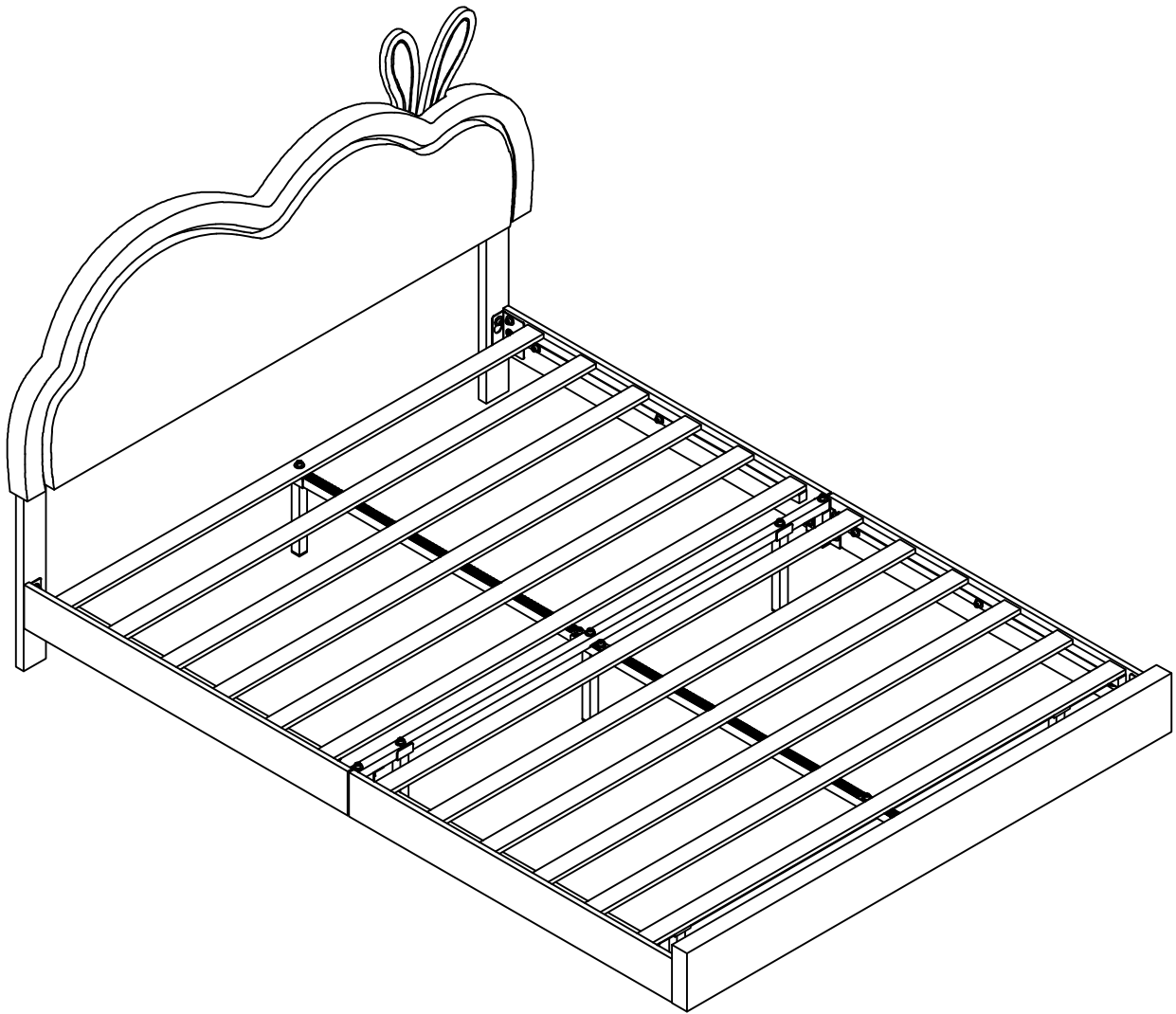

Installation Complete