

## Upholstered Platform Bed with Tufted Wingback Headboard(Y102H-K)

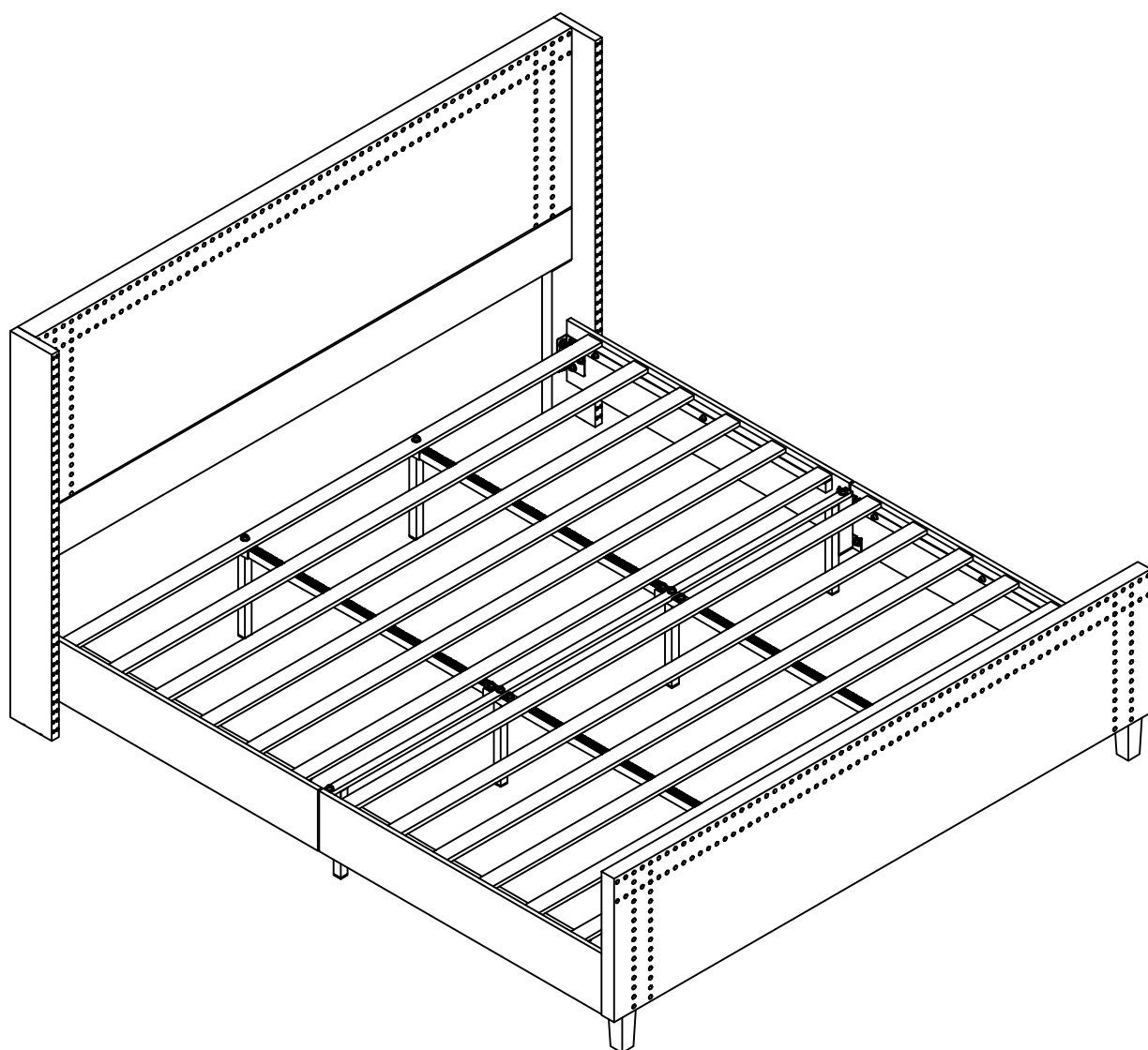

### **Friendly Customer Service**

Satisfaction Guarantees: Any problems with assembly, quality, or return, please feel free to contact us directly.

### **Contact us**

Phone: +1 (901) 347-2181 (US) Mon-Fri 9am - 5pm (PST)

E-Mail: [cs@howedirect.com](mailto:cs@howedirect.com) (Get efficient feedback within 12 hours)

# ! IMPORTANT

Please follow the instruction manuals and use a pad to protect the product during your assembly.

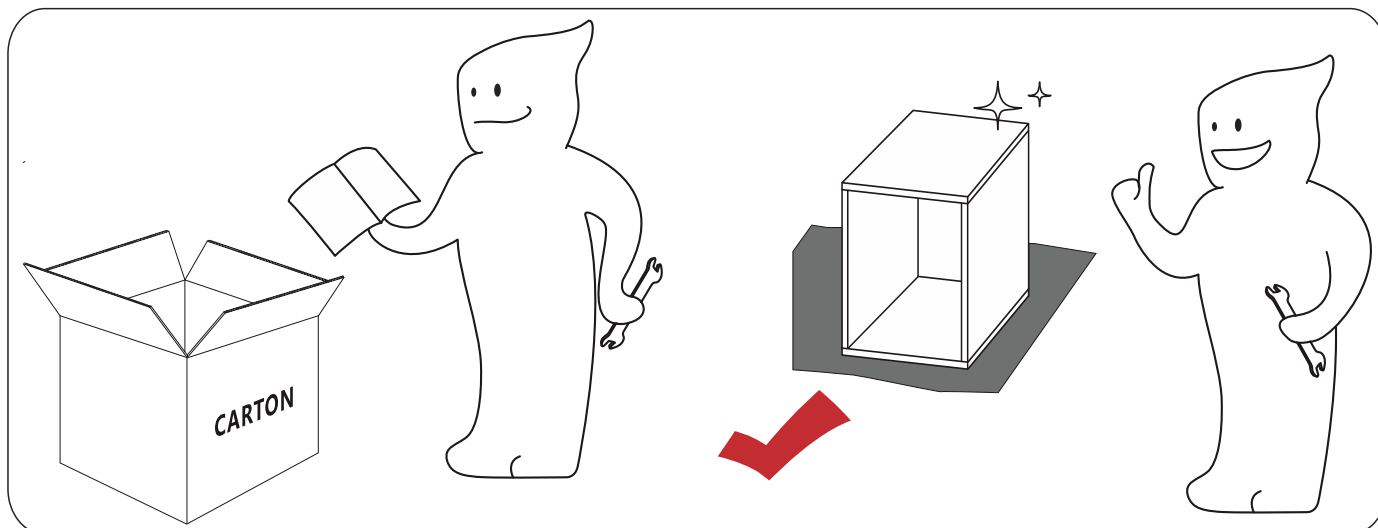
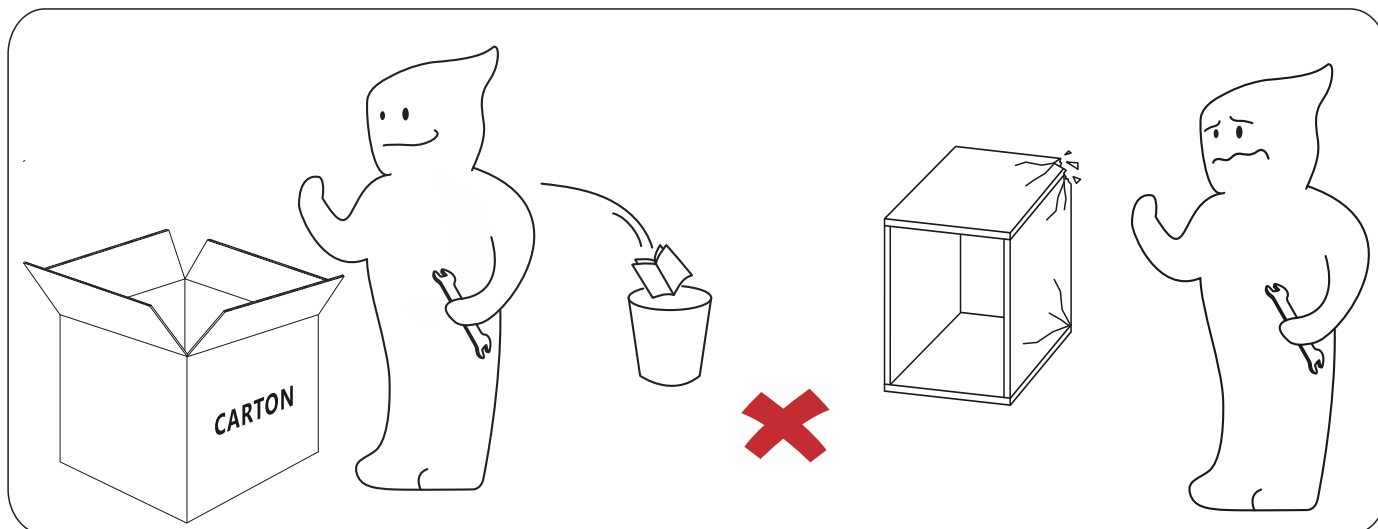

**Note:**

1. Should be assembled on flat ground to keep balance.
2. Before completing the installation, do not tighten the screws.

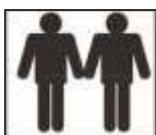

For easier and better assembly, **2** or more adults are required.

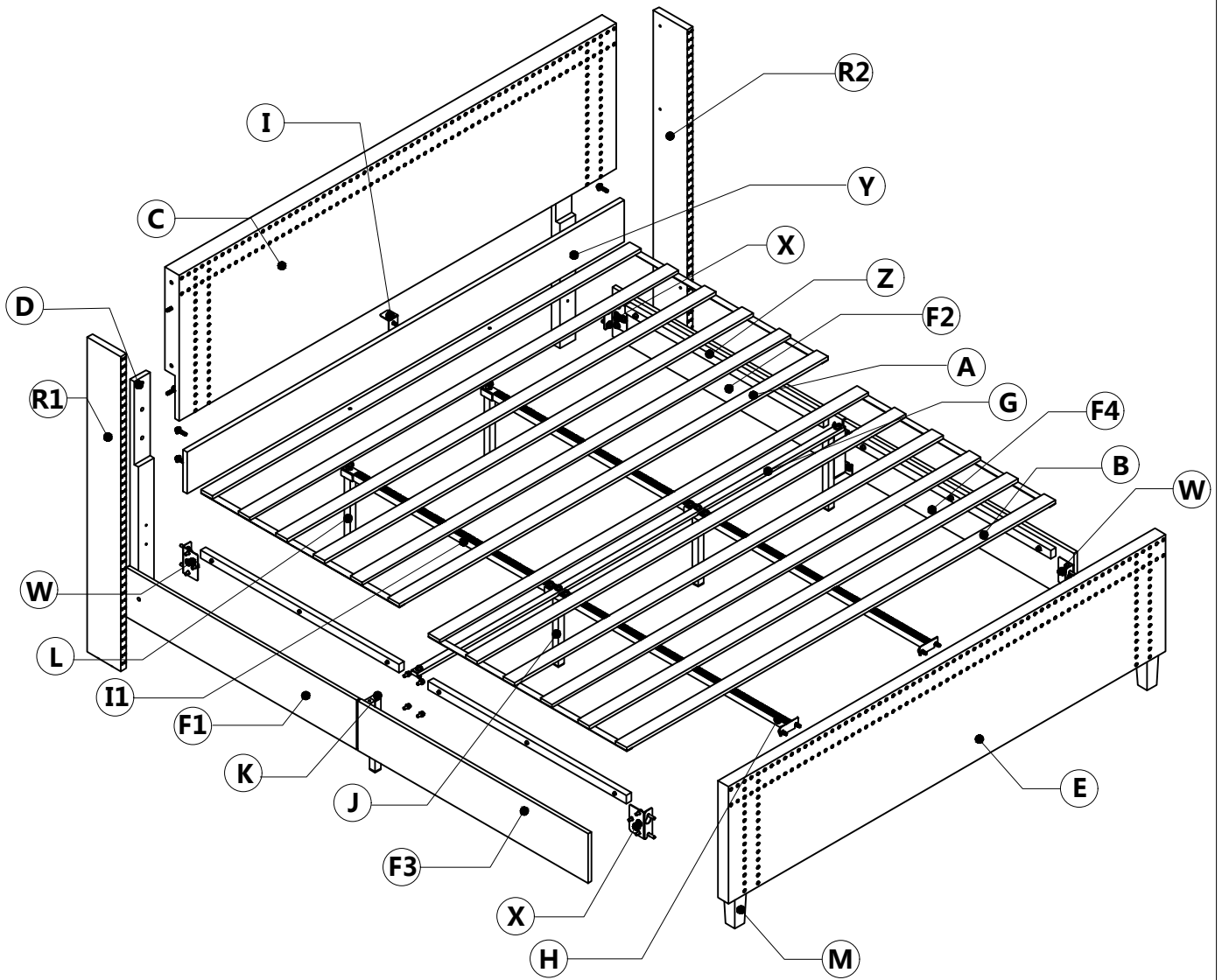

# ASSEMBLY INSTRUCTIONS

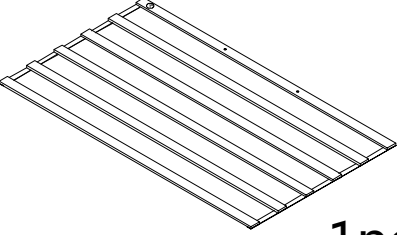
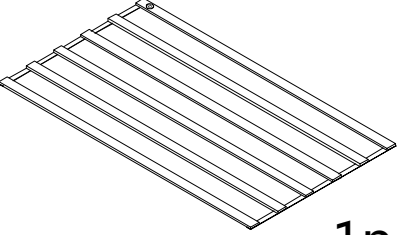
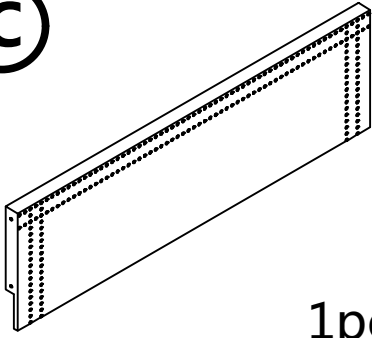
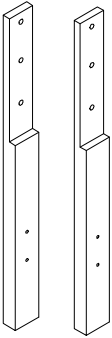
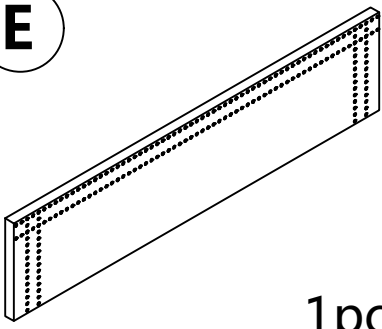
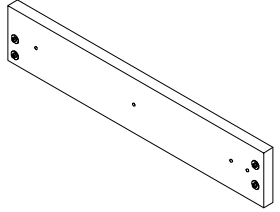
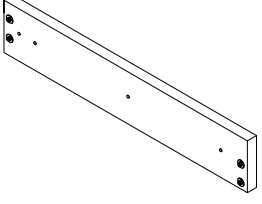
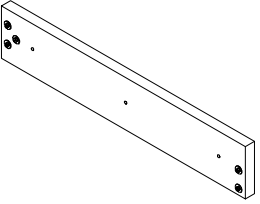
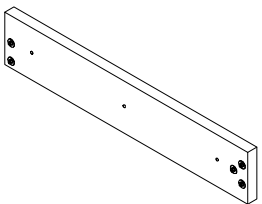
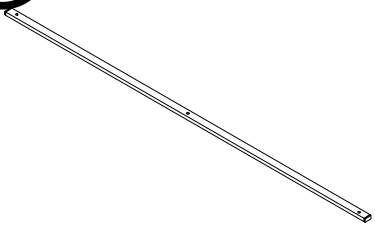
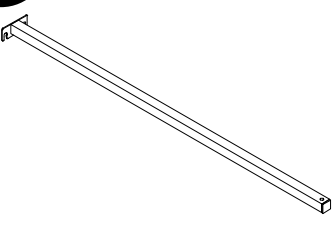
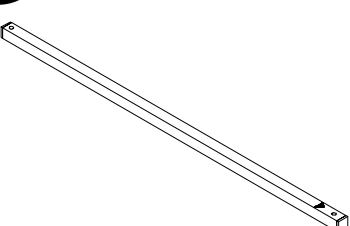
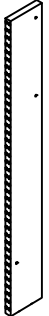
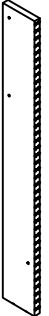
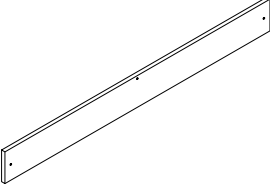
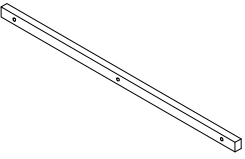

**BED FRAME PARTS LIST**

<p><b>(A)</b></p>  <p>1pc</p>	<p><b>(B)</b></p>  <p>1pc</p>	<p><b>(C)</b></p>  <p>1pc</p>	
<p><b>(D)</b></p>  <p>2pcs</p>	<p><b>(E)</b></p>  <p>1pc</p>	<p><b>(F1)</b></p>  <p>1pc</p>	
<p><b>(F2)</b></p>  <p>1pc</p>	<p><b>(F3)</b></p>  <p>1pc</p>	<p><b>(F4)</b></p>  <p>1pc</p>	
<p><b>(G)</b></p>  <p>1pc</p>	<p><b>(H)</b></p>  <p>2pcs</p>	<p><b>(I1)</b></p>  <p>2pcs</p>	
<p><b>(R1)</b></p>  <p>1pc</p>	<p><b>(R2)</b></p>  <p>1pc</p>	<p><b>(Y)</b></p>  <p>1pc</p>	<p><b>(Z)</b></p>  <p>4pcs</p>

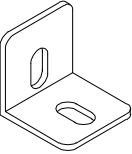
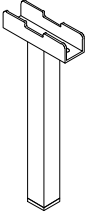
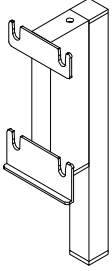
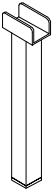
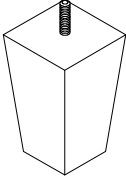
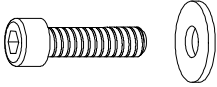
**FITTING PARTS LIST**

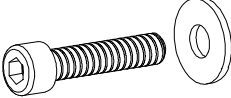
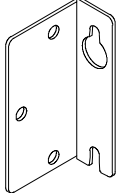
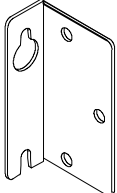

<p><b>I</b></p>  <p>1pc</p>	<p><b>J</b></p>  <p>2pcs</p>	<p><b>K</b></p>  <p>2pcs</p>
<p><b>L</b></p>  <p>2pcs</p>	<p><b>M</b></p>  <p>2pcs</p>	<p><b>N</b></p>  <p>M8 X40mm 30+1pcs</p>
<p><b>P</b></p>  <p>M8 Spanner 1pc</p>	<p><b>Q</b></p>  <p>M8 X45mm 4pcs</p>	<p><b>W</b></p>  <p>2pcs</p>
<p><b>X</b></p>  <p>2pcs</p>		

# ASSEMBLY INSTRUCTIONS

## STEP 1

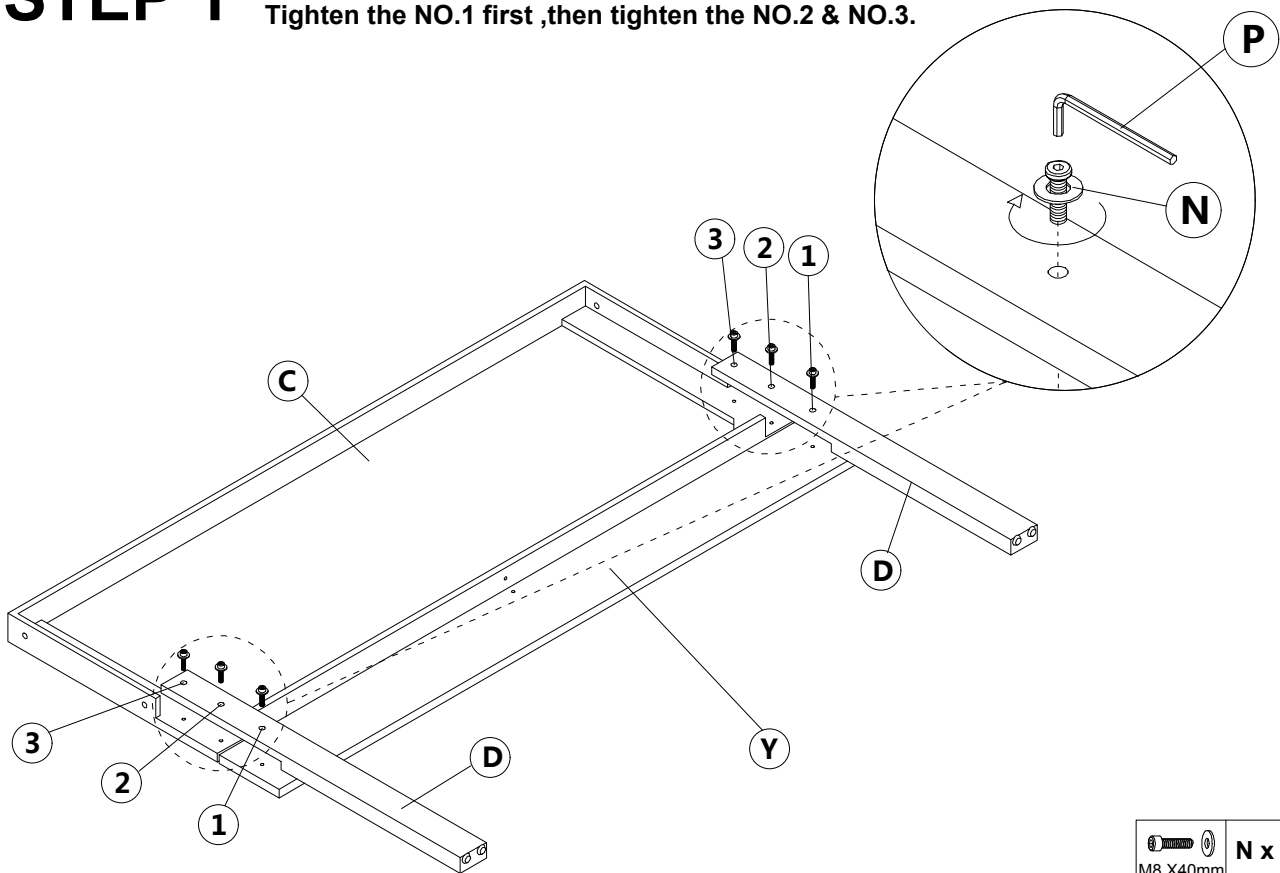
Tighten the NO.1 first ,then tighten the NO.2 & NO.3.





	N x 6pcs
M8 X40mm	
	P x 1pc

## STEP 2

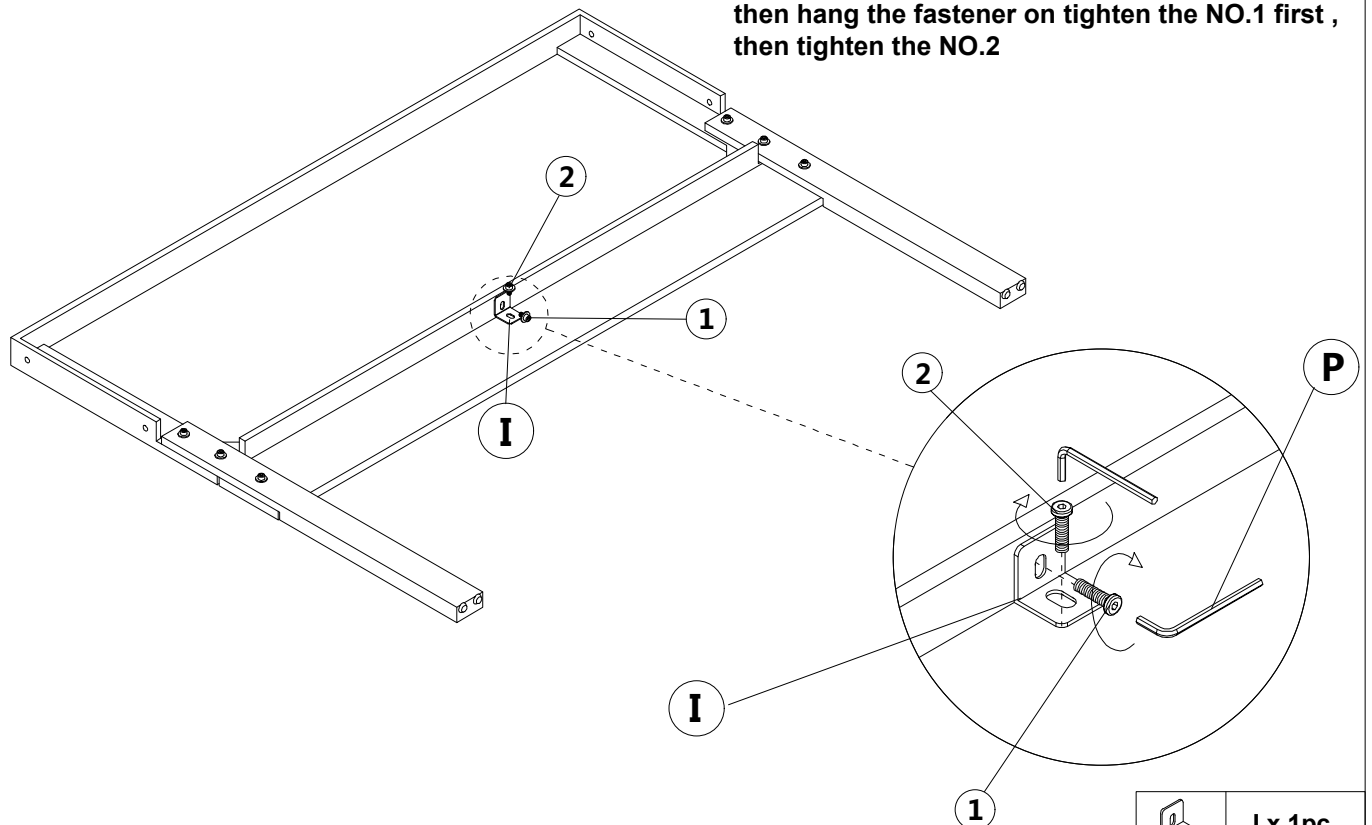
Loosen the screw of headboard and baffle, then hang the fastener on tighten the NO.1 first , then tighten the NO.2



	I x 1pc
	P x 1pc

## STEP 3

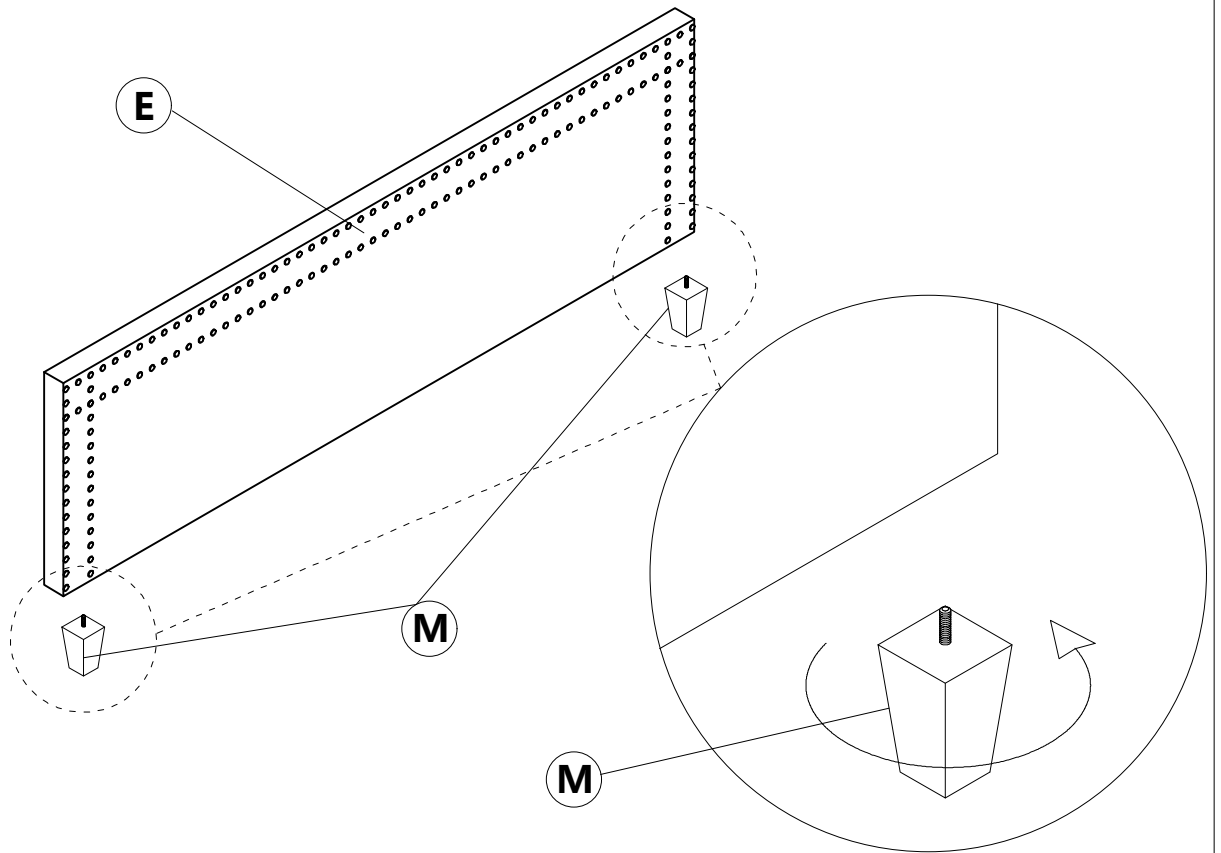

## STEP 4

Take out parts F1 and F3, and lock the iron frame foot K in the middle according to the figure. Note that there are 2 holes located on the inner side of the board. Then lock the bed hanging pieces W/X on the front and rear of the board, with 3 holes on each side.

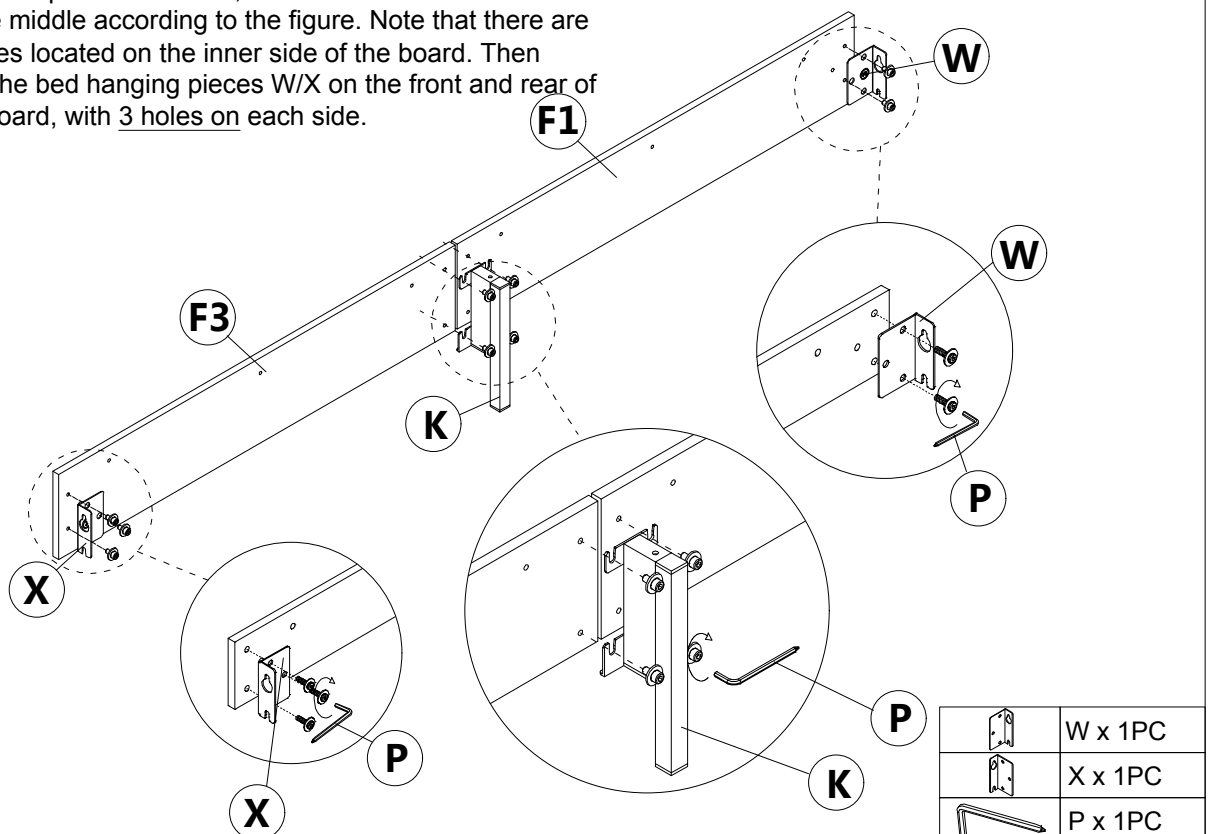

## STEP 5

Same as Step 4

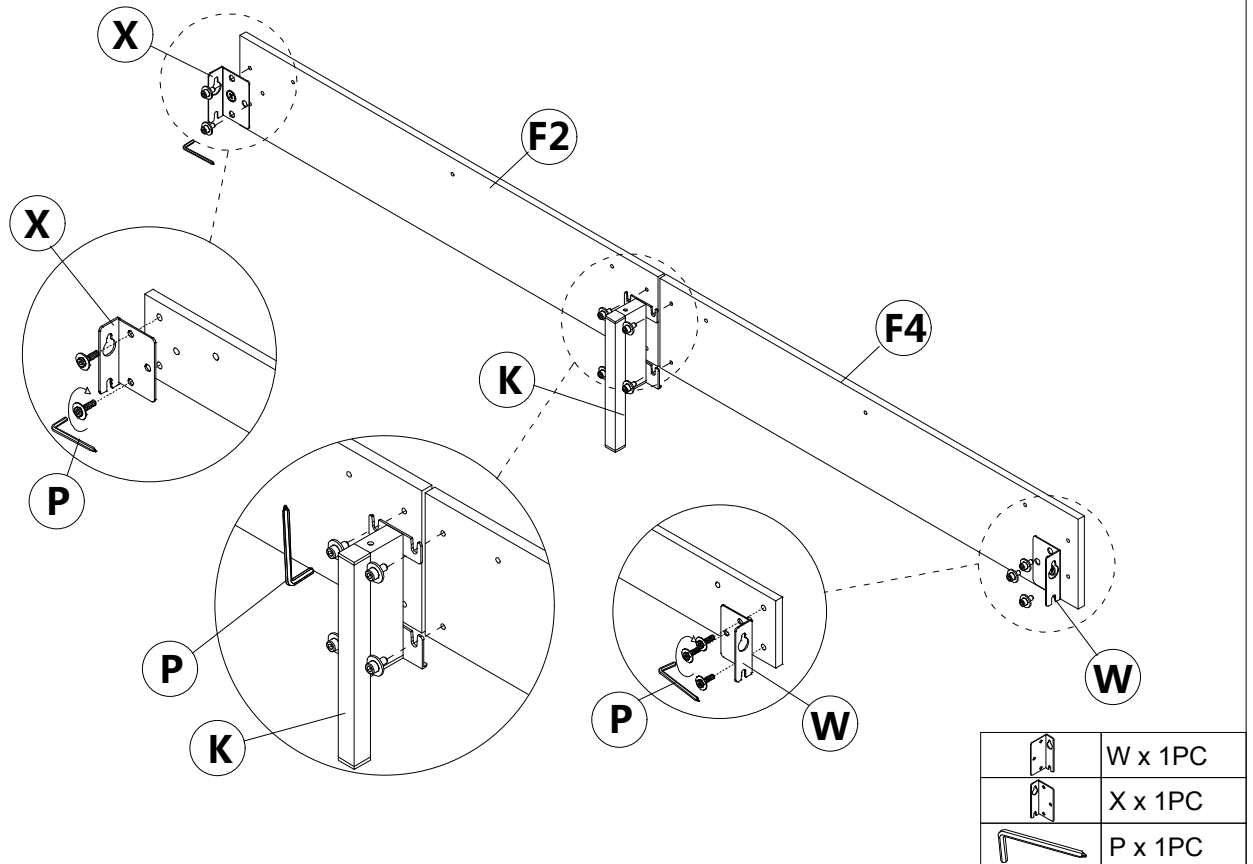

## STEP 6

Loosen the screw of headboard side leg and both sides of footboard, then hang the bracket on tighten the innerscrew.

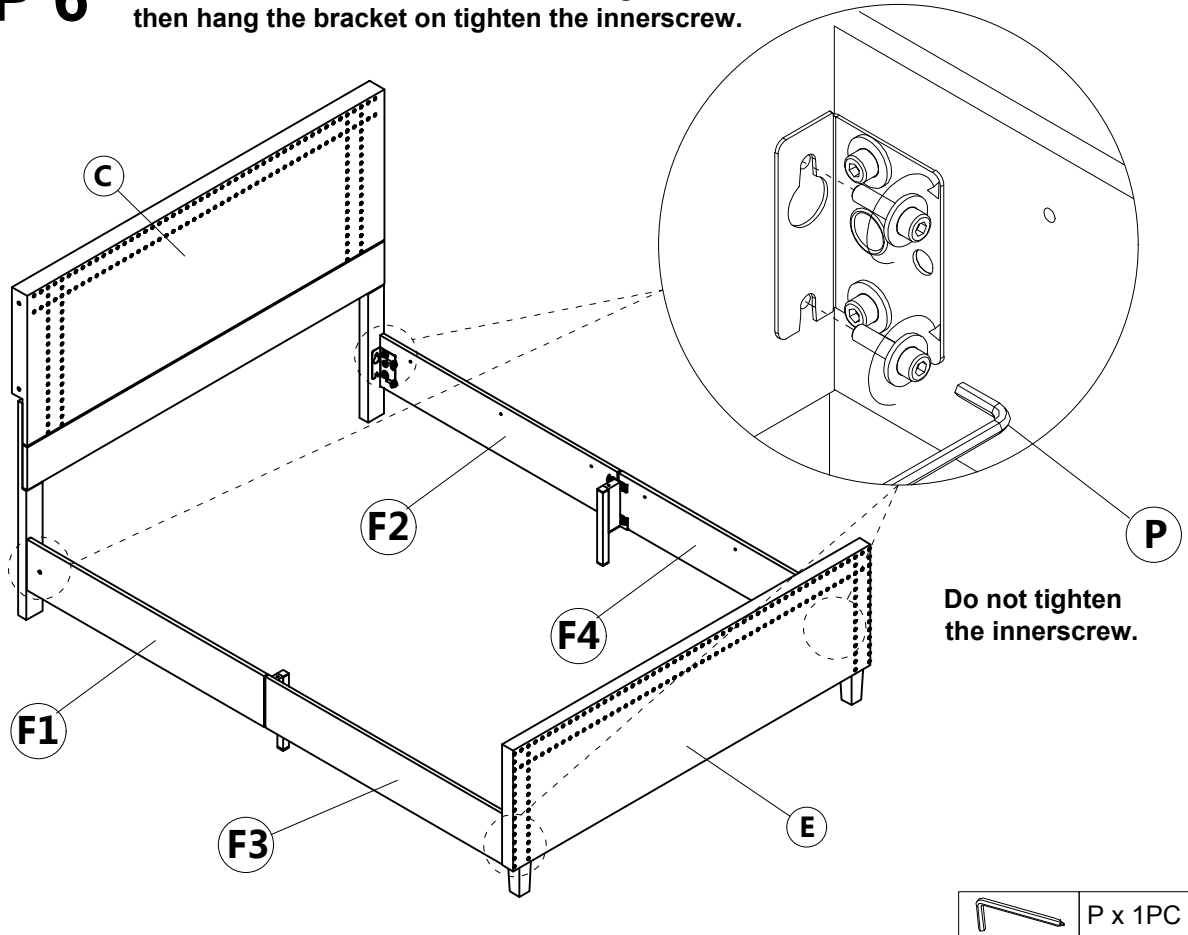



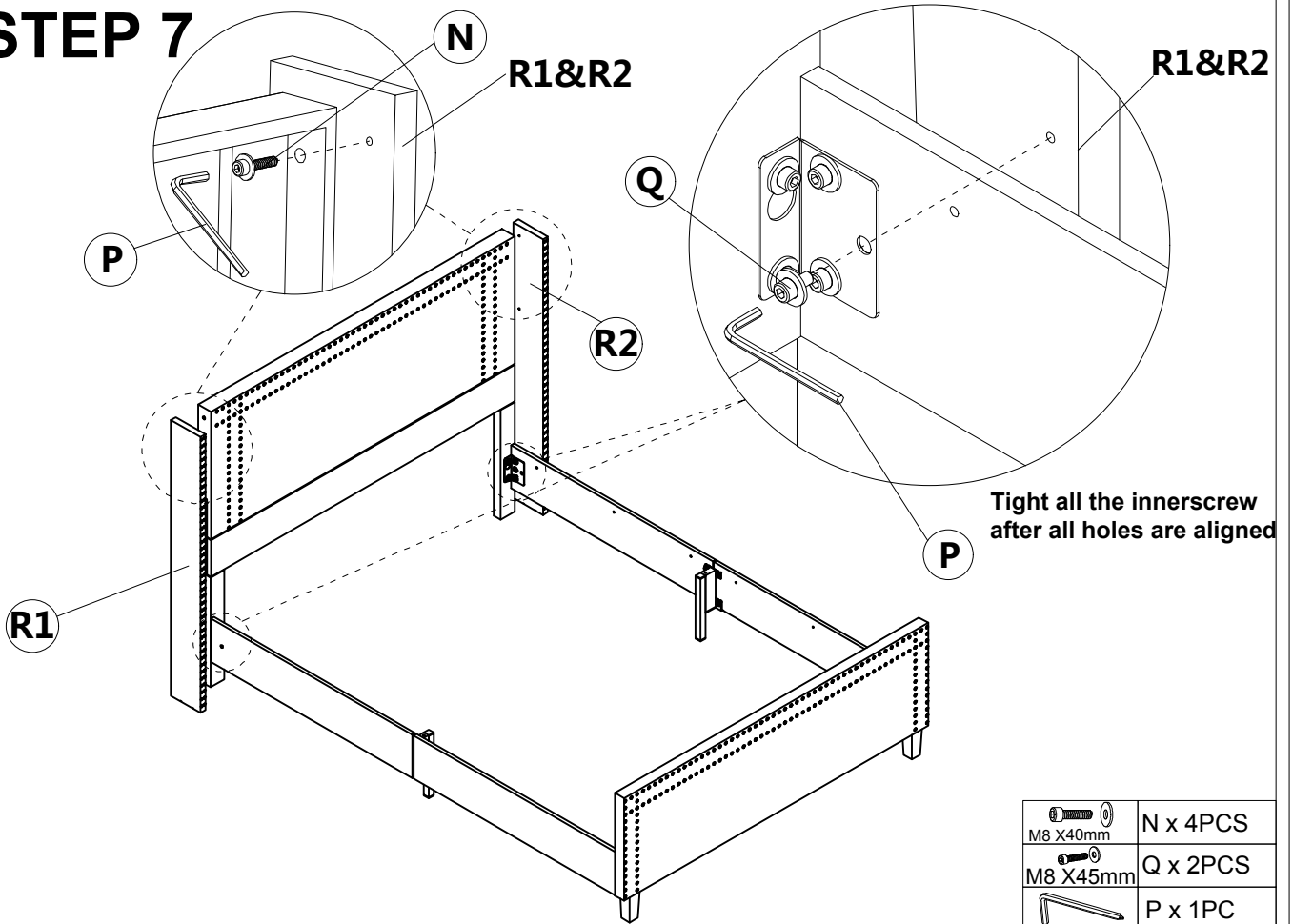

# ASSEMBLY INSTRUCTIONS

## STEP 7





 M8 X40mm	N x 4PCS
 M8 X45mm	Q x 2PCS
 P	P x 1PC

## STEP 8

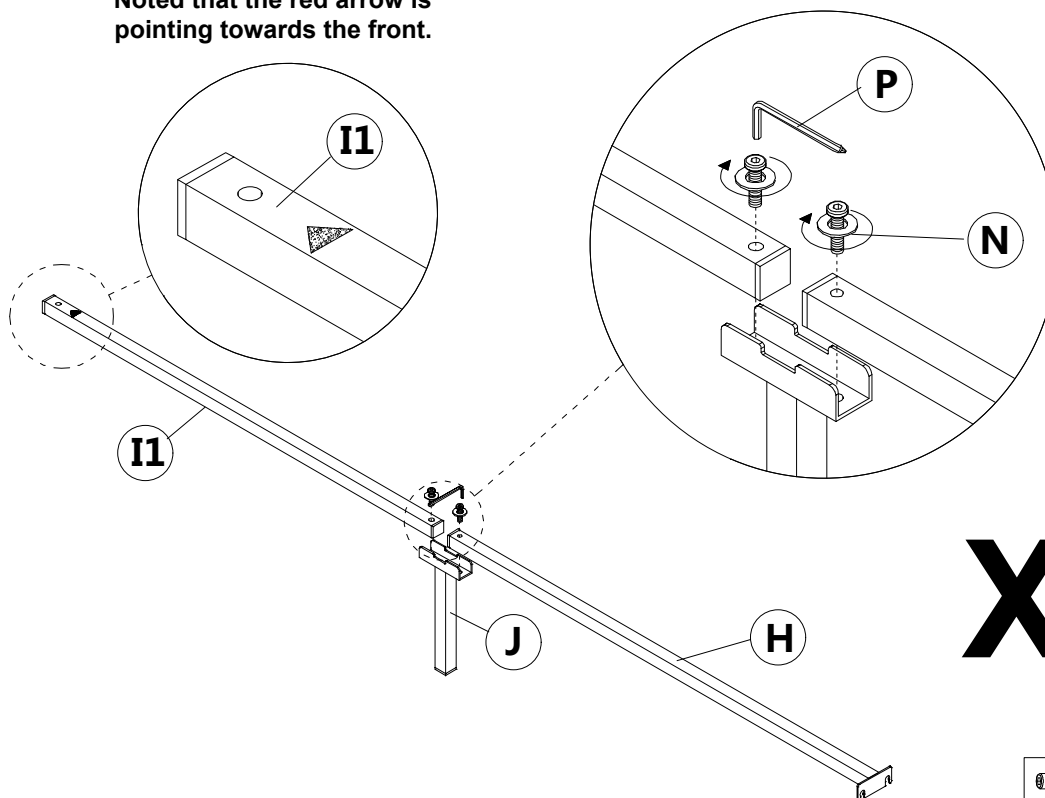
Noted that the red arrow is pointing towards the front.



 M8 X40mm	N x 4pcs
 P	P x 1pc

## STEP 9

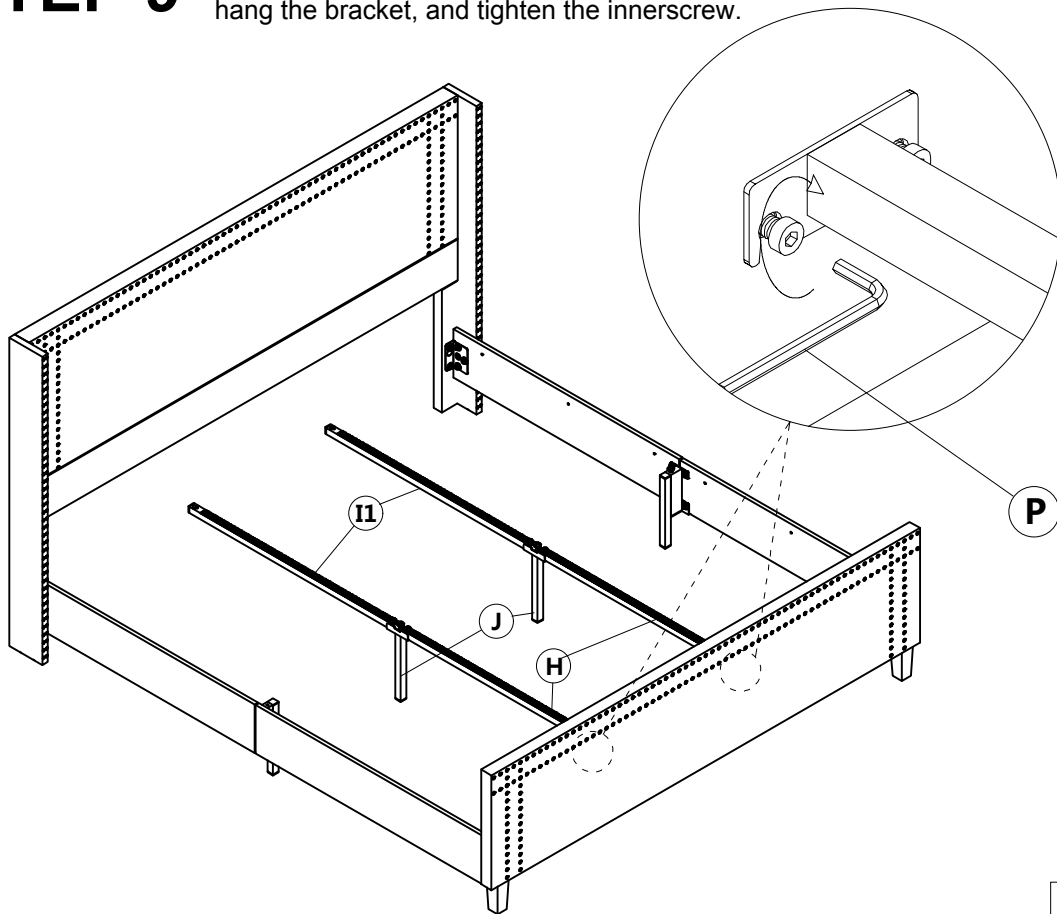

Loosen the screw in the middle of the footboard, hang the bracket, and tighten the innerscrew.

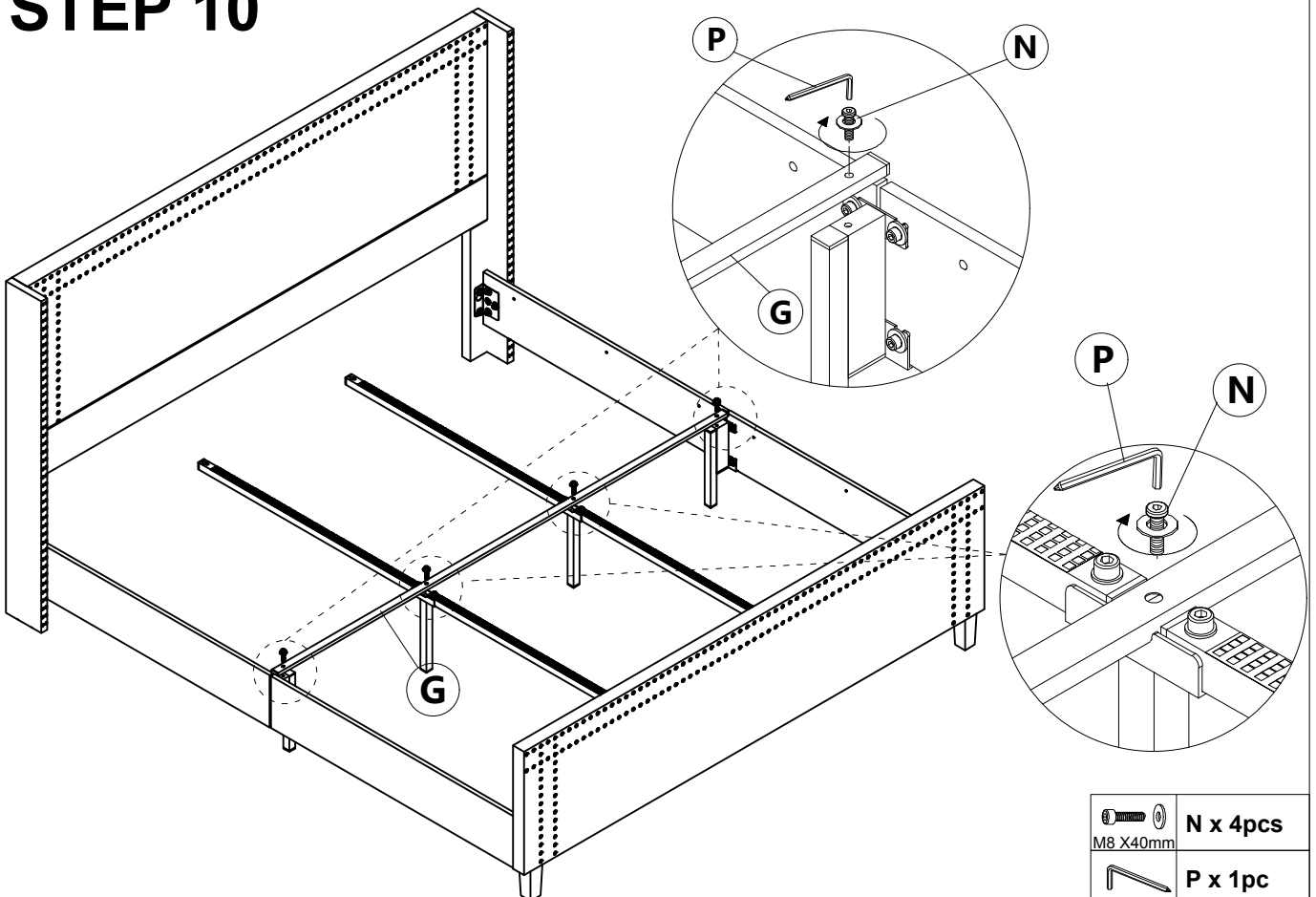

	P x 1PC
---	---------

## STEP 10



	N x 4pcs M8 X40mm
	P x 1pc

## STEP 11

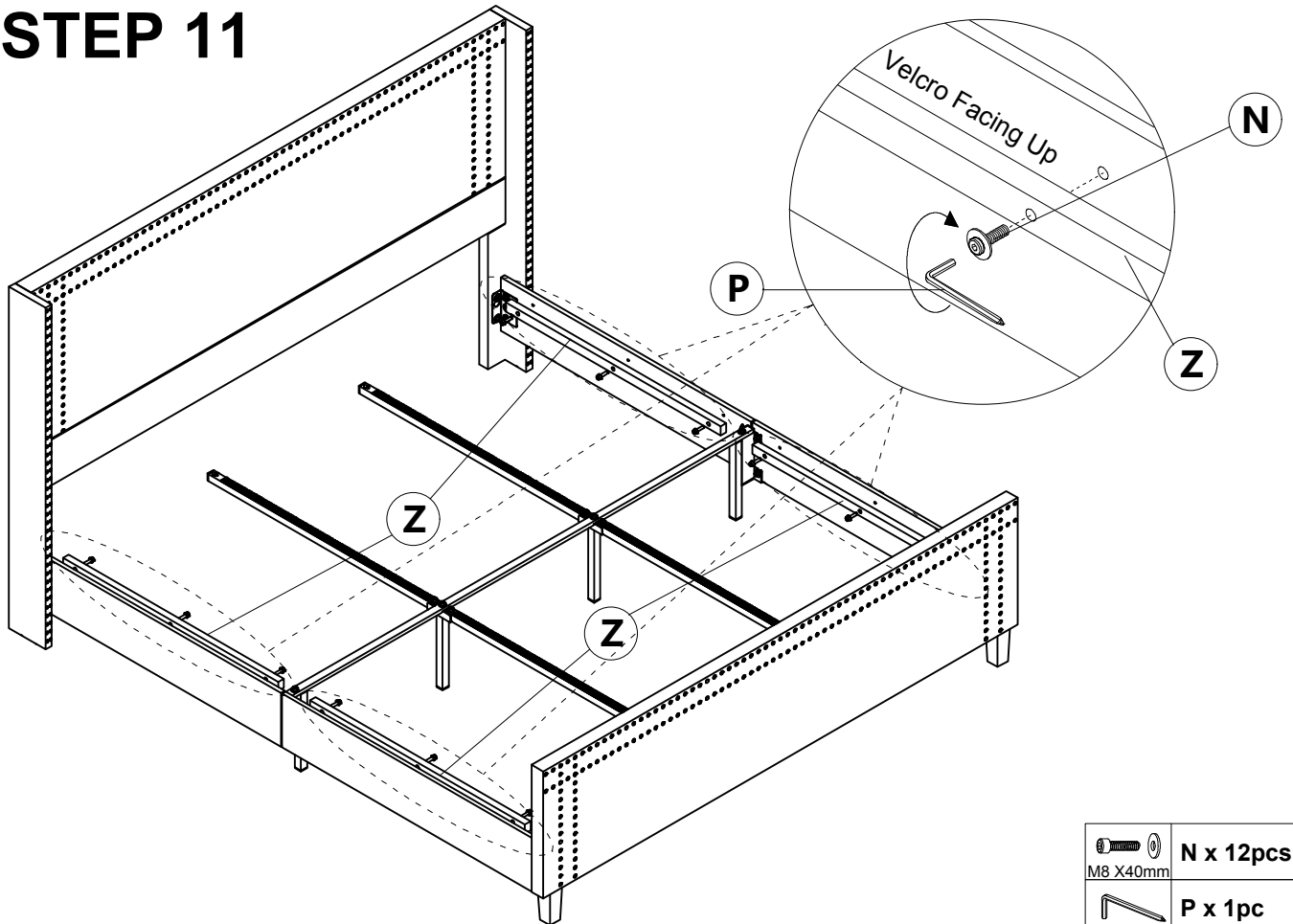

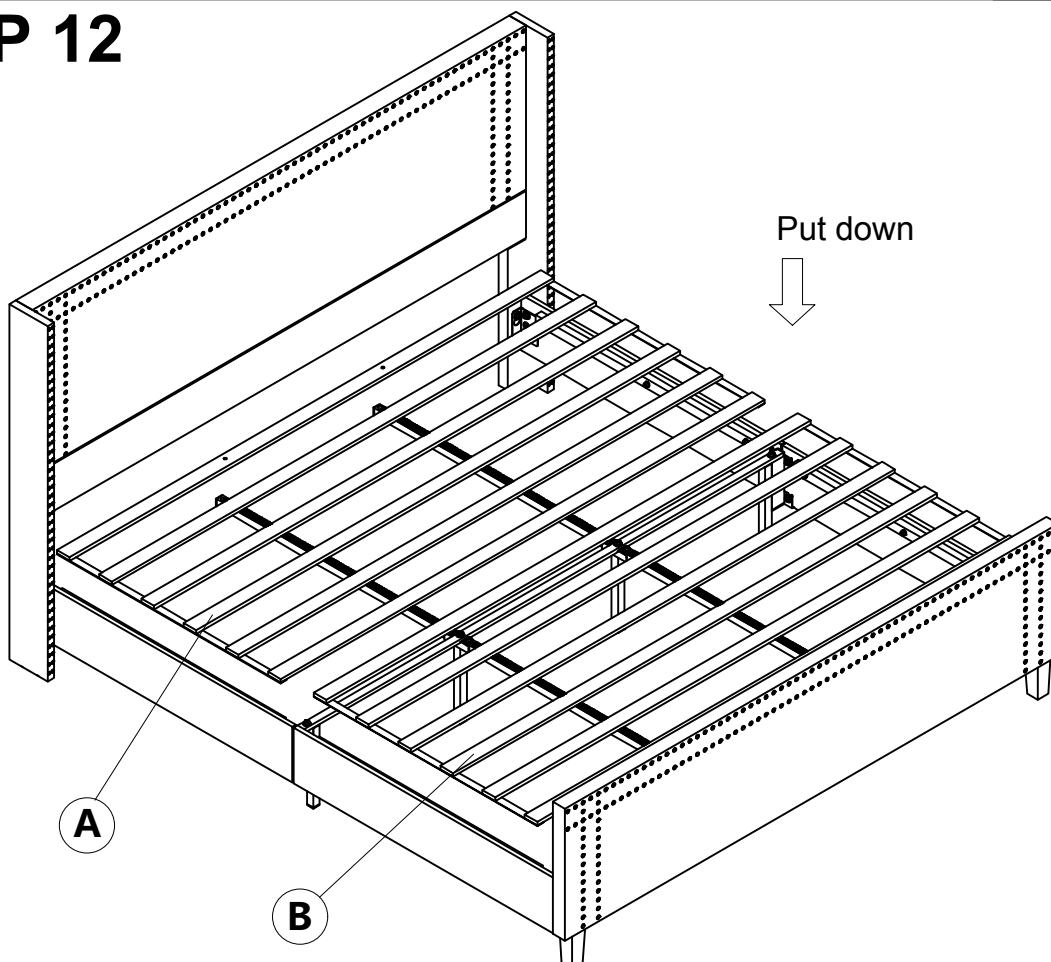

## STEP 12

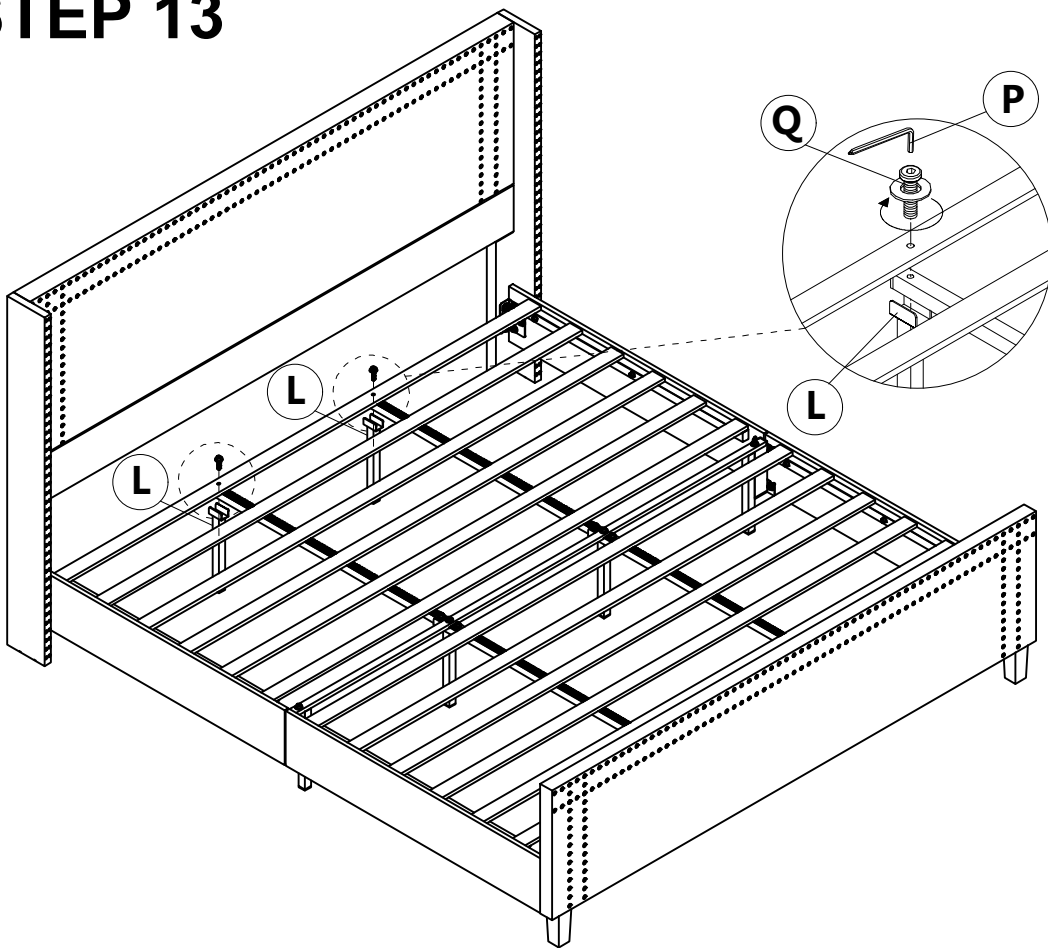

## STEP 13



 M8 X45mm	<b>Q x 2pcs</b>
	<b>P x 1pc</b>

## STEP 14

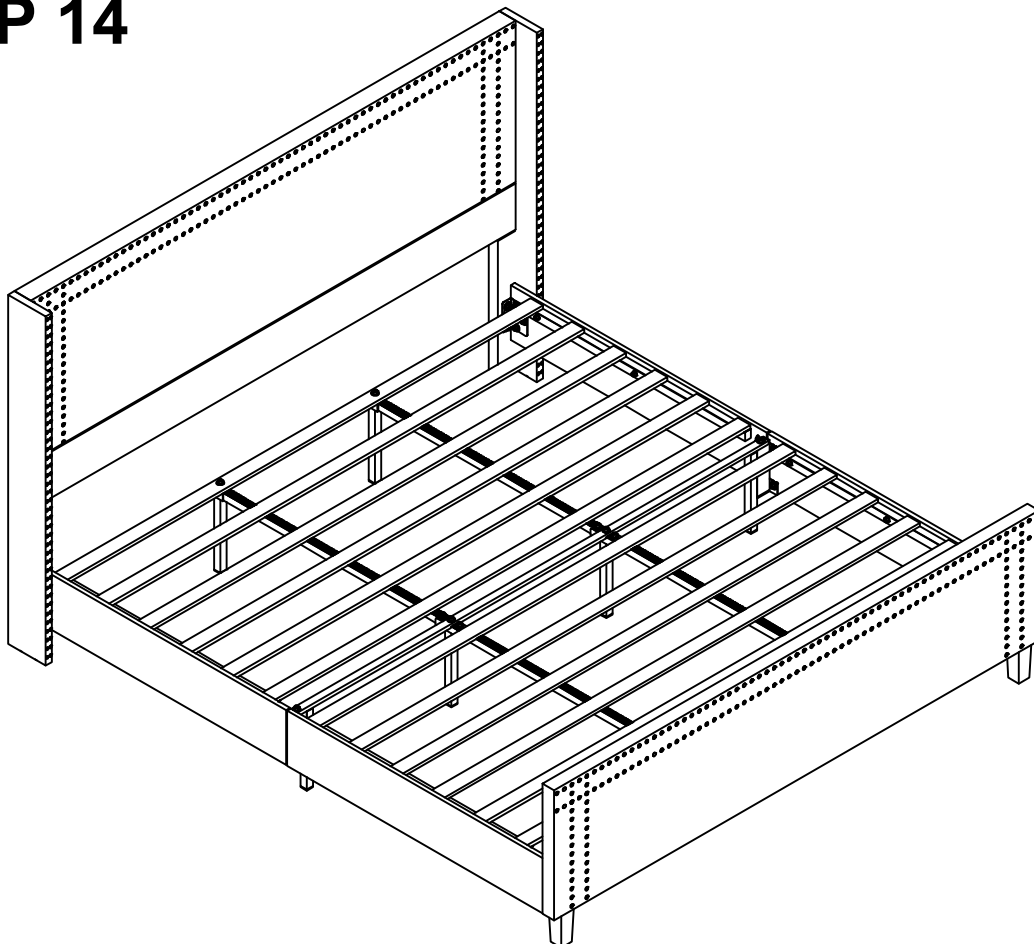

# STEP 15

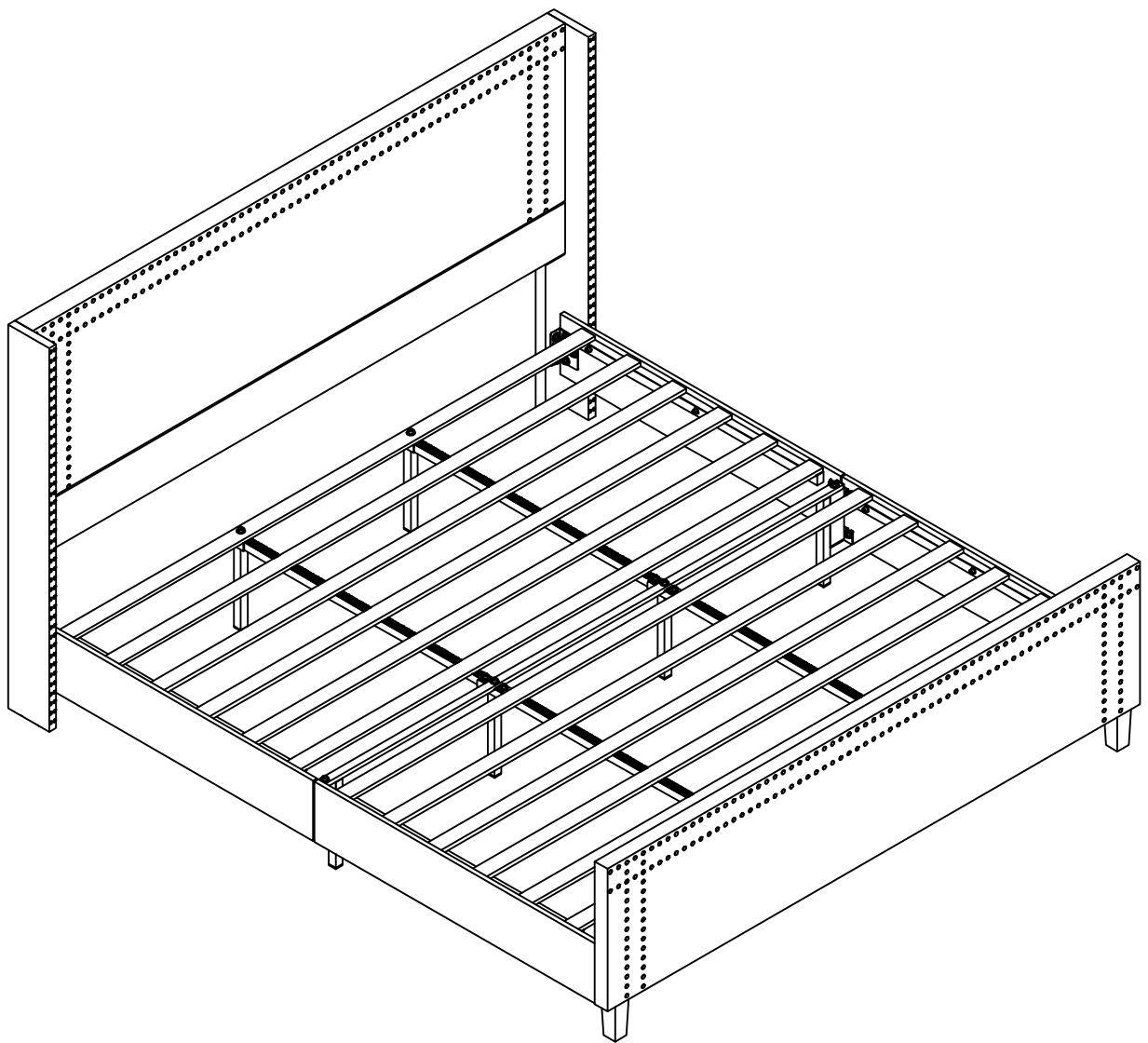

Installation Complete