

# Dining table - 4 chairs - 1 bench

**Assembly Instructions - Please keep for future reference**

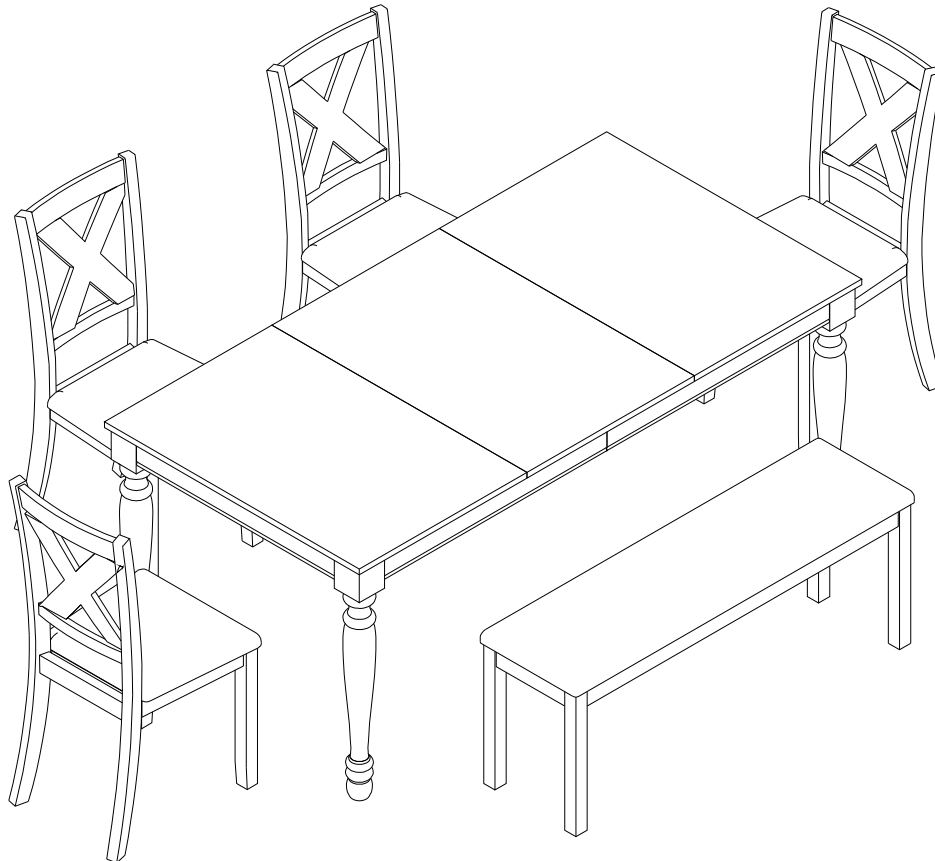

## **Table Dimensions**

Width - 70.9inch  
Depth - 36inch  
Height - 30inch

## **Chair Dimensions**

Width - 18.3inch  
Depth - 22.3inch  
Height - 36.6inch

## **Bench Dimensions**

Width - 48inch  
Depth - 13.8inch  
Height - 19inch

**Delivered with TWO PACKAGES with TWO TRACKINGS, may NOT be delivered at the same time.**

Any question please feel free to contact us:  
support@amer-life.com TEL:(901) 347-2181  
We will provide further assistance within 24 hours.

**Important – Please read these instructions fully before starting assembly**

**Seller's Notice:**



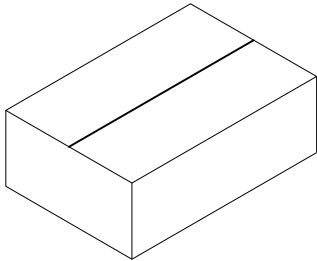

Our product is packed in separate boxes as shown below, and they might be shipped in different batches. Please wait until you received all the boxes then start the assembly.

Noted: Assembly instruction is only provided in Box1.

The following is the list of components contained in each box.

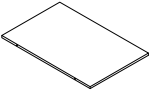
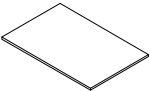
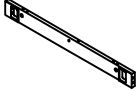
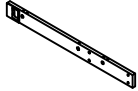
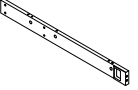
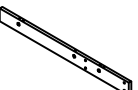
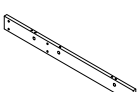

**Main structure accessories**



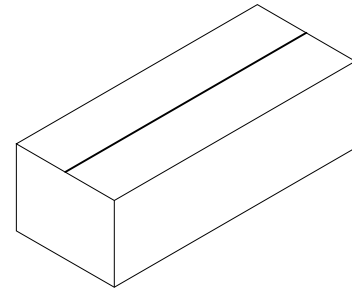

- |           |   |                      |    |
|-----------|---|----------------------|----|
| <b>1</b>  |    | Center panel         | x1 |
| <b>2</b>  |   | Side panel           | x2 |
| <b>3</b>  |  | Build up short side  | x2 |
| <b>4</b>  |  | Build up 1 long side | x2 |
| <b>5</b>  |  | Build up 2 long side | x2 |
| <b>6</b>  |  | Build up 1 center    | x1 |
| <b>7</b>  |  | Build up 2 center    | x1 |
| <b>8</b>  |  | Build up connect     | x3 |
| <b>9</b>  |  | Table leg            | x4 |
| <b>11</b> |  | Seat cushion         | x4 |

**HARDWARE**

**All hardware are in Box 1.**

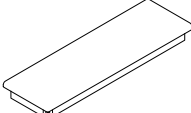

**Main structure accessories**

- |           |   |                    |    |
|-----------|---|--------------------|----|
| <b>10</b> |    | Chair back         | x4 |
| <b>12</b> |   | Chair leg          | x8 |
| <b>13</b> |   | Bench seat cushion | x1 |
| <b>14</b> |  | Bench leg          | x4 |



## Safety and Care Advice

**Important – Please read these instructions fully before starting assembly**

- Check you have all the components and tools listed on the following pages.
- Remove all fittings from the plastic bags and separate them into their groups.
- Keep children and animals away from the work area, small parts could choke if swallowed.
- Make sure you have enough space to layout the parts before starting.

- During assembly do not stand or put weight on the product, this could cause damage.
- Assemble the item as close to its final position (in the same room) as possible.
- Assemble on a soft level surface to avoid damaging the unit or your floor.
- Parts of the assembly will be easier with 2 people.



- To reduce the likelihood of damaging your product please ensure that your power drill is set on a low torque setting.

### Care and maintenance

- Only clean using a damp cloth and mild detergent, do not use bleach or abrasive cleaners.
- From time to time check that there are no loose screws on this unit.
- This product should not be discarded with household waste. Take to your local authority waste disposal centre.

### Handy Hints

- Assemble all parts and bolts loosely during assembly, only once the product is complete should you fully tighten the bolts
- Regularly check and ensure That all bolts and fittings are tightend properly.

## WARNING

**In order to help prevent overturning – please follow these instructions**

To help prevent product toppling over please follow the below steps:-

Use the anti tip stap or wall fixing method provided (if applicable)  
Do not allow children to climb or hang on the furniture  
Do not open more than one drawer at a time  
Do not place heavy items in the top drawers  
Do not place heavy items on top of the furniture, unless the furniture has been designed for this purpose

please note that only the anti tip strap is provided.  
You will need to provide wall plugs and screws applicable for your wall type

# Components - Panels

Please check you have all the panels listed below

## Table

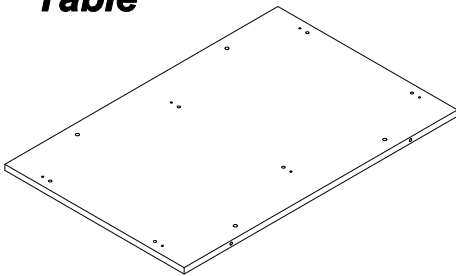

1 (914x600x18mm) X 1

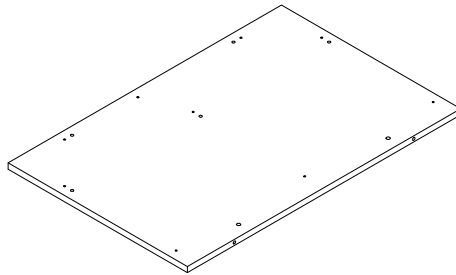

2 (914x600x18mm) X 2

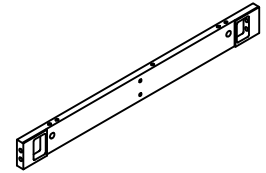

3 (710x75x23mm) X 2

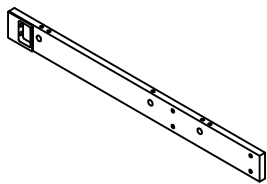

4 (798x75x23mm) X 2

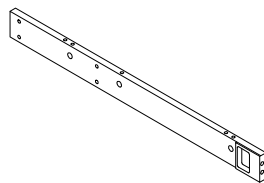

5 (798x75x23mm) X 2

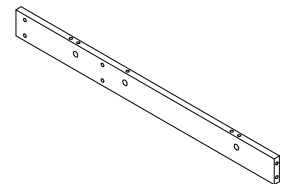

6 (864x75x18mm) X 1

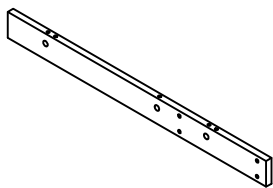

7 (864x75x18mm) X 1

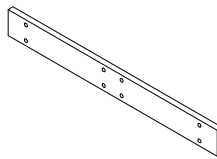

8 (700x75x18mm) X 3



9 (90x90x742mm) X 4

## Chair X4

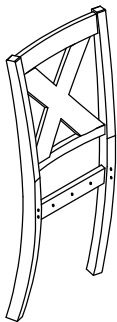

10 (930x465x115mm) X 1

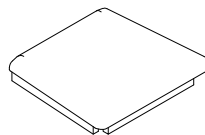

11 (430x395x95mm) X 1



12 (40x40x430mm) X 2

## Bench

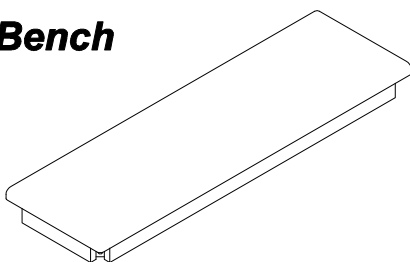

13 (1220x360x102mm) X 1















14 (40x40x440mm) X 4

# Components - Fittings







Please check you have all the hardware listed below

The quantities below are the correct amount to complete the assembly. In some cases more fittings may be supplied than are required.





**Table**

<b>A</b>  1/4"x15mm Bolt x 8	<b>B</b>  1/4"x32mm Bolt x 24	<b>C</b>  1/4" Lock washer x 32
<b>D</b>  1/4"x16mm Flat washer x 32	<b>E</b>  Male Camlock x 24	<b>F</b>  Female Camlock x 24
<b>G</b>  5/16"x80mm Bolt x 16	<b>H</b>  5/16"x16mm Flat washer x 16	<b>I</b>  5/16" Nut x 16
<b>J</b>  Mounting plate metal x 4	<b>K</b>  Ø8x30mm Dowel x 24	<b>R</b>  Allen key 4mm x 1
<b>S</b>  Allen wrench x 1		

**Chair X4**

<b>L</b>  1/4"x76mm Bolt x 4	<b>M</b>  1/4"x60mm Bolt x 4	<b>N</b>  1/4"x32mm Bolt x 2
<b>O</b>  1/4" Lock washer x 10	<b>P</b>  1/4"x16mm Flat washer x 10	<b>R</b>  Allen key 4mm x 1

**Bench**

<b>Q</b>  1/4"x50mm Bolt x 8	<b>O</b>  1/4" Lock washer x 8	<b>P</b>  1/4"x16mm Flat washer x 8	<b>R</b>  Allen key 4mm x 1
--	--	--	---

## Tools required



**Ruler - Use this ruler to help correctly identify the screws**

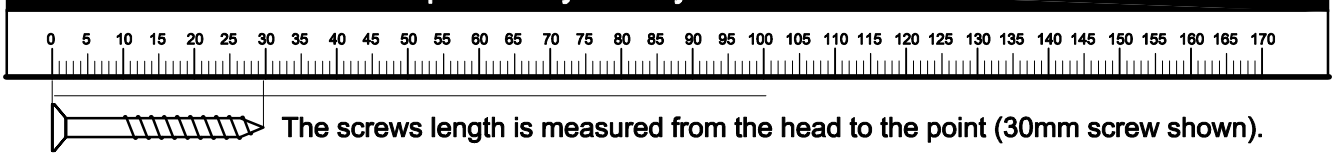

# Using Camlocks

## Step 1

Connect the male camlock as directed in the assembly instructions using a screwdriver.

1

DO NOT OVER TIGHTEN.  
NE PAS SERRER EXCESSIVEMENT.

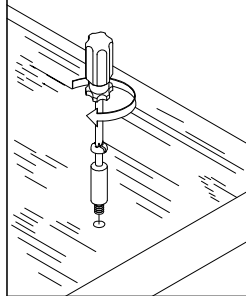

## Step 2

Push the male camlock into the entry hole.

2

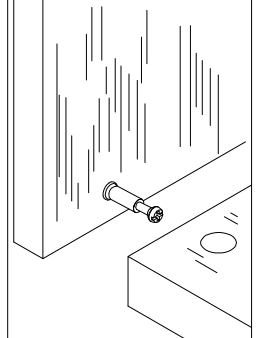

## Step 3

Insert the female camlock as shown in the instruction.

Note: ensure that the arrow on the top of the camlock points towards the entry hole for the male camlock.

3

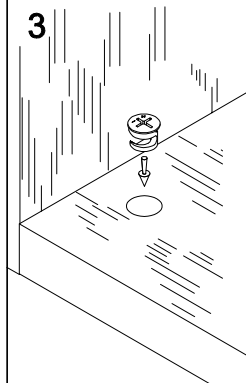

## Step 4

Turn the female camlock clockwise with a screwdriver.

You should feel a click when the camlock is locked in place.

The joint is now secure.

4

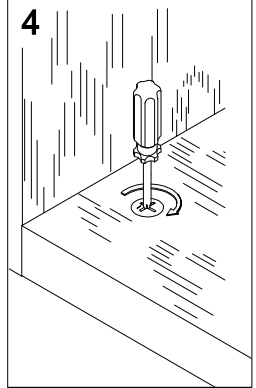

# Assembly Instructions

## Table

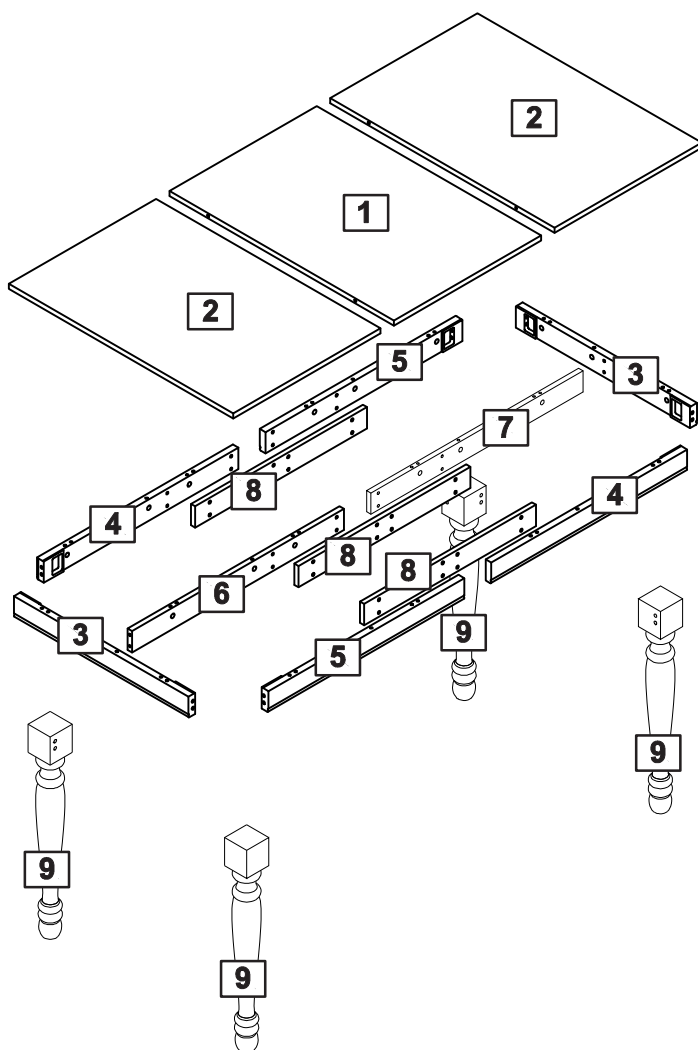

## Chair X4

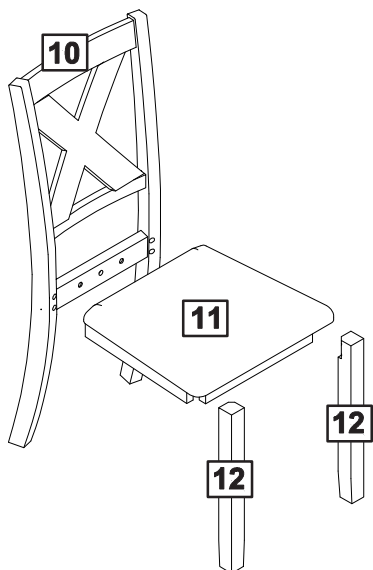

## Bench

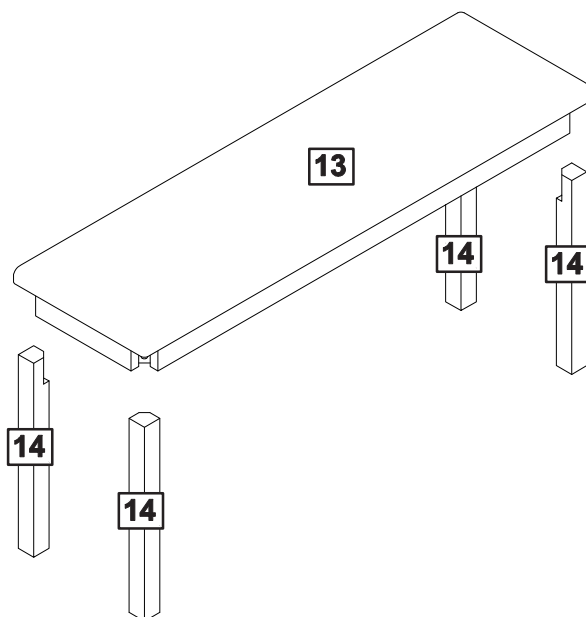

# Assembly Instructions

## Step 1

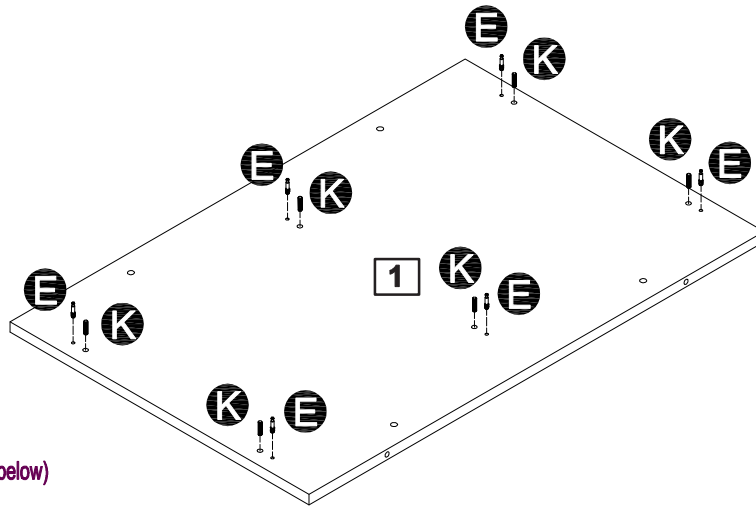
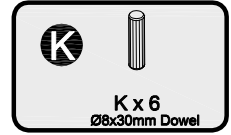
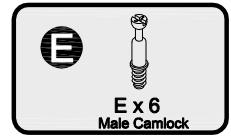

**CAM-LOCK**  
Tighten until shoulder is flush with panel. Do not overtighten or undertighten (see example below)

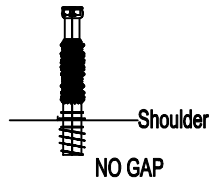
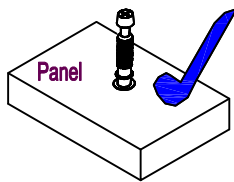
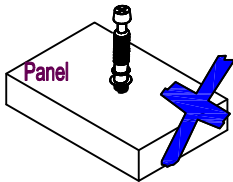

## Step 2

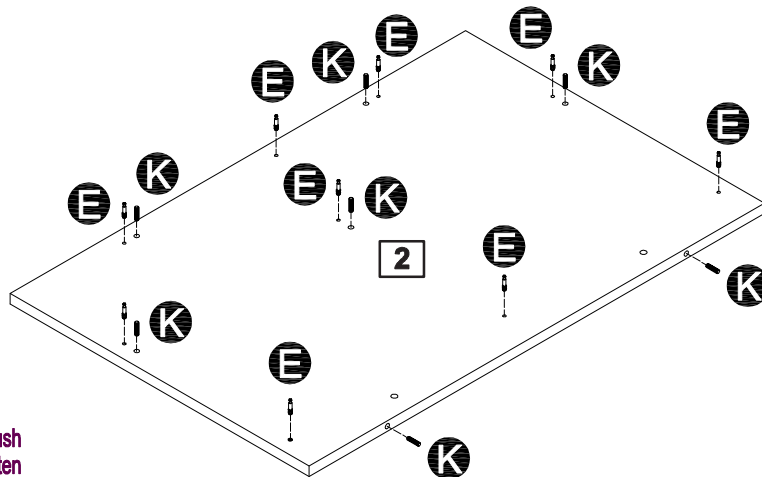
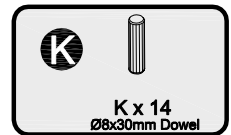
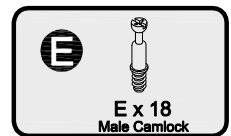

**CAM-LOCK**  
Tighten until shoulder is flush with panel. Do not overtighten or undertighten (see example below)

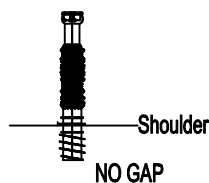
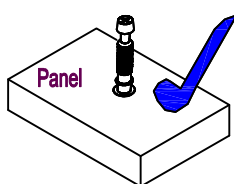
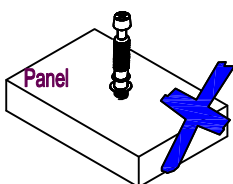

x2



# Assembly Instructions

## Step 3

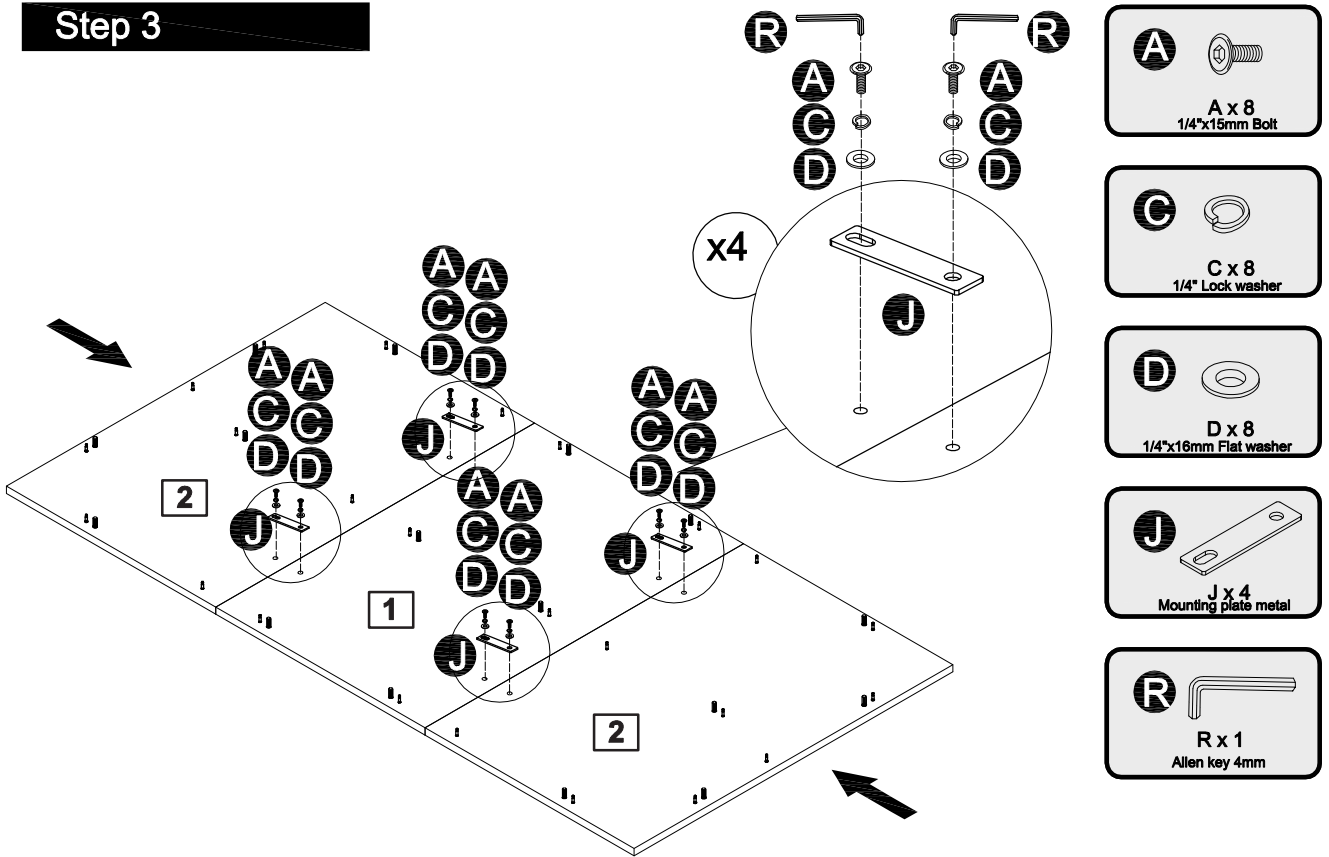

## Step 4

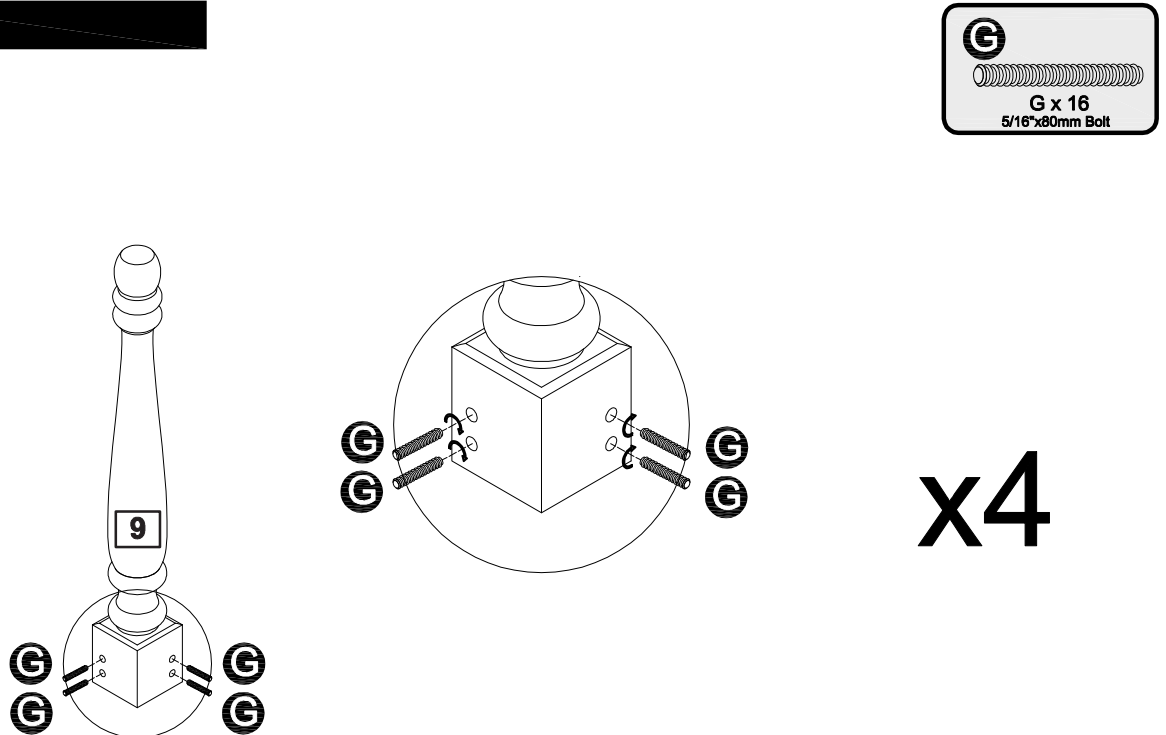

# Assembly Instructions

## Step 5

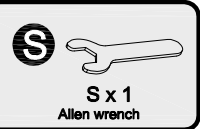
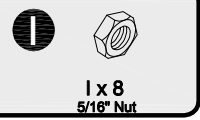
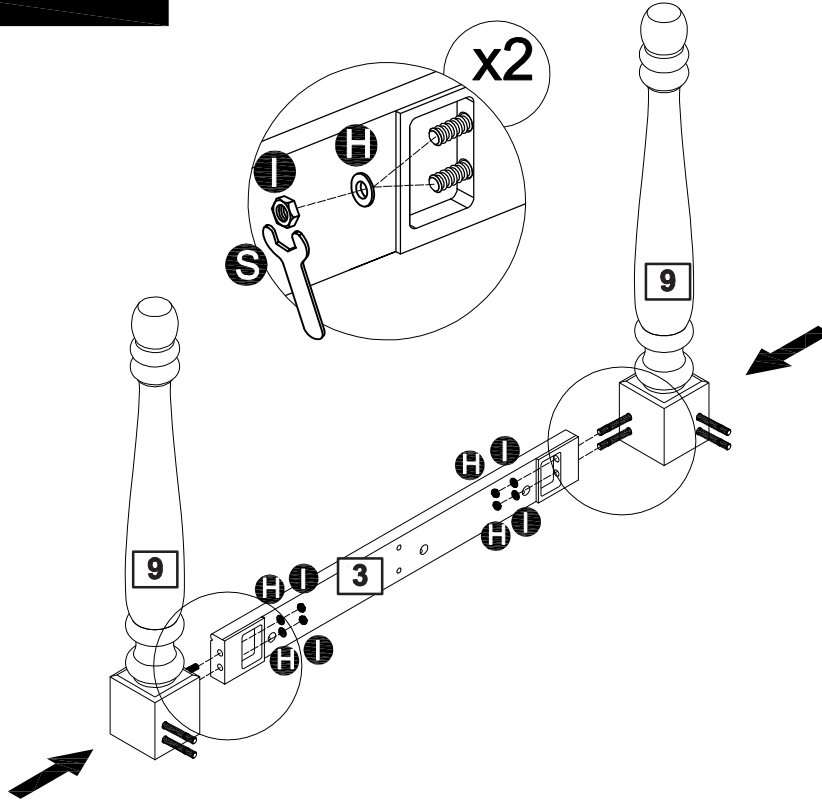

x2

## Step 6

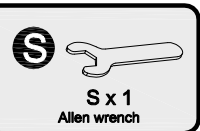
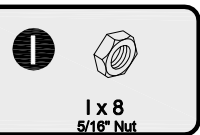
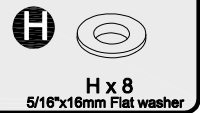
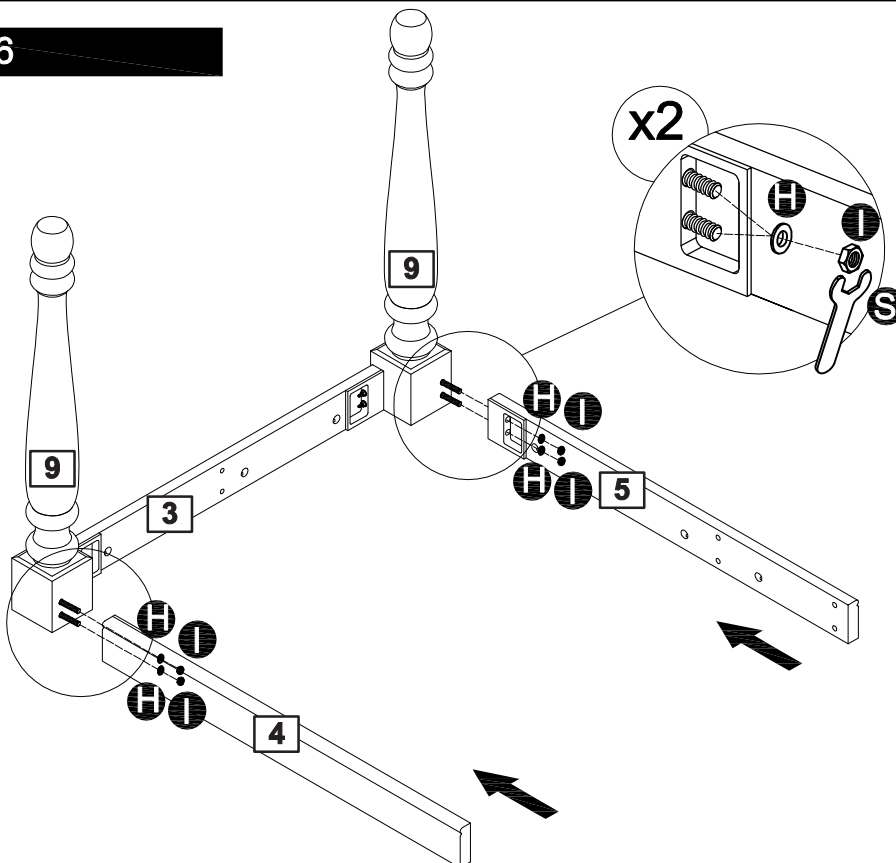

x2

# Assembly Instructions

## Step 7

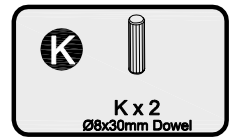
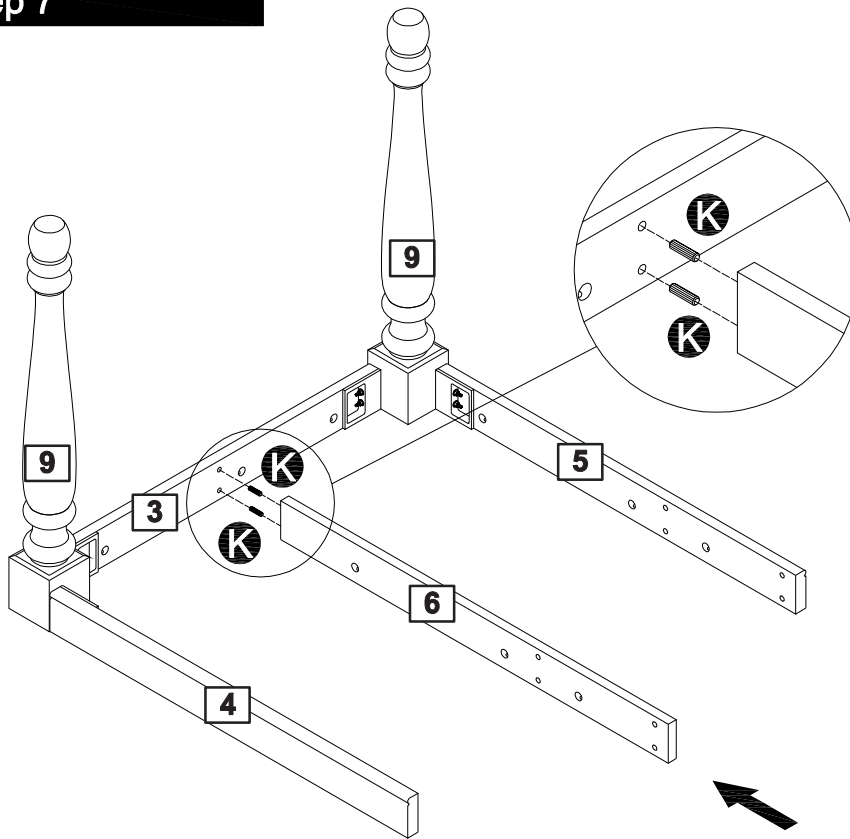

## Step 8

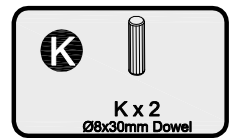
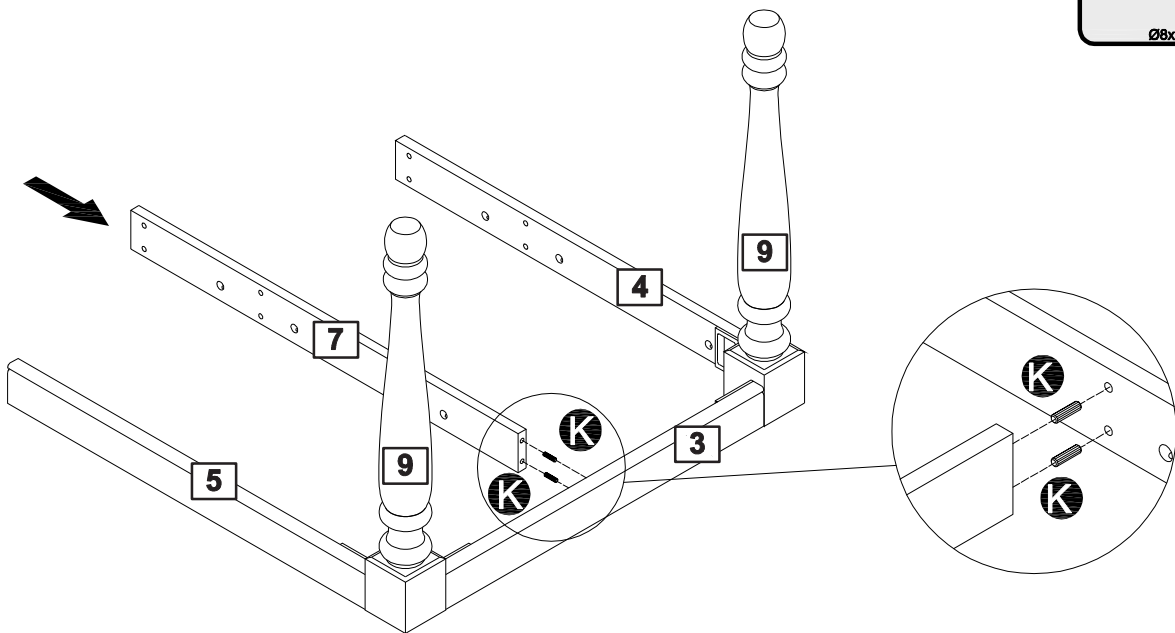

# Assembly Instructions

## Step 9

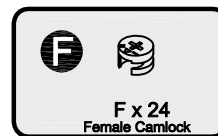
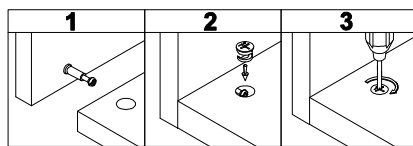

**CAM-LOCK**  
Tighten until shoulder is flush with panel. Do not overtighten or undertighten (see example below)

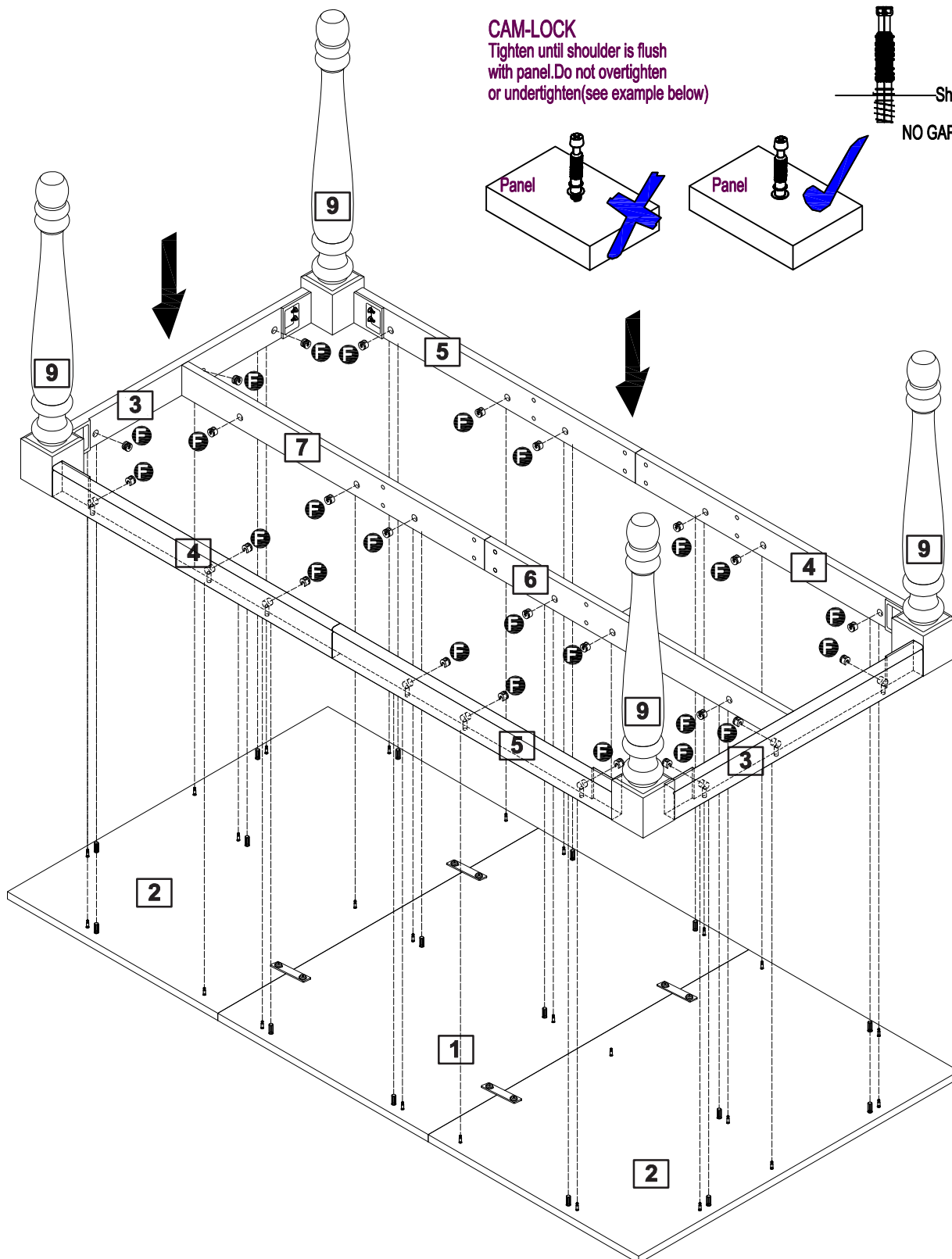
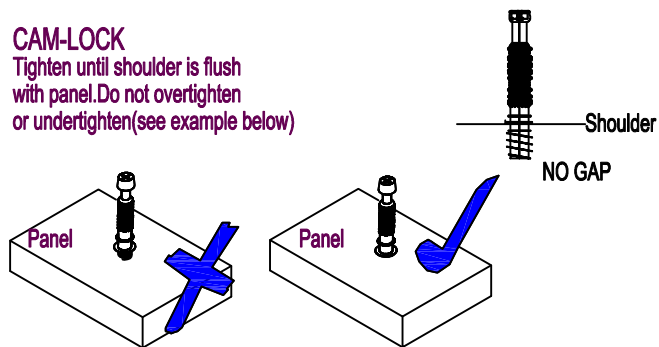

# Assembly Instructions

## Step 10



B x 24  
1/4"x32mm Bolt



C x 24  
1/4" Lock washer



D x 24  
1/4"x16mm Flat washer



R x 1  
Allen key 4mm

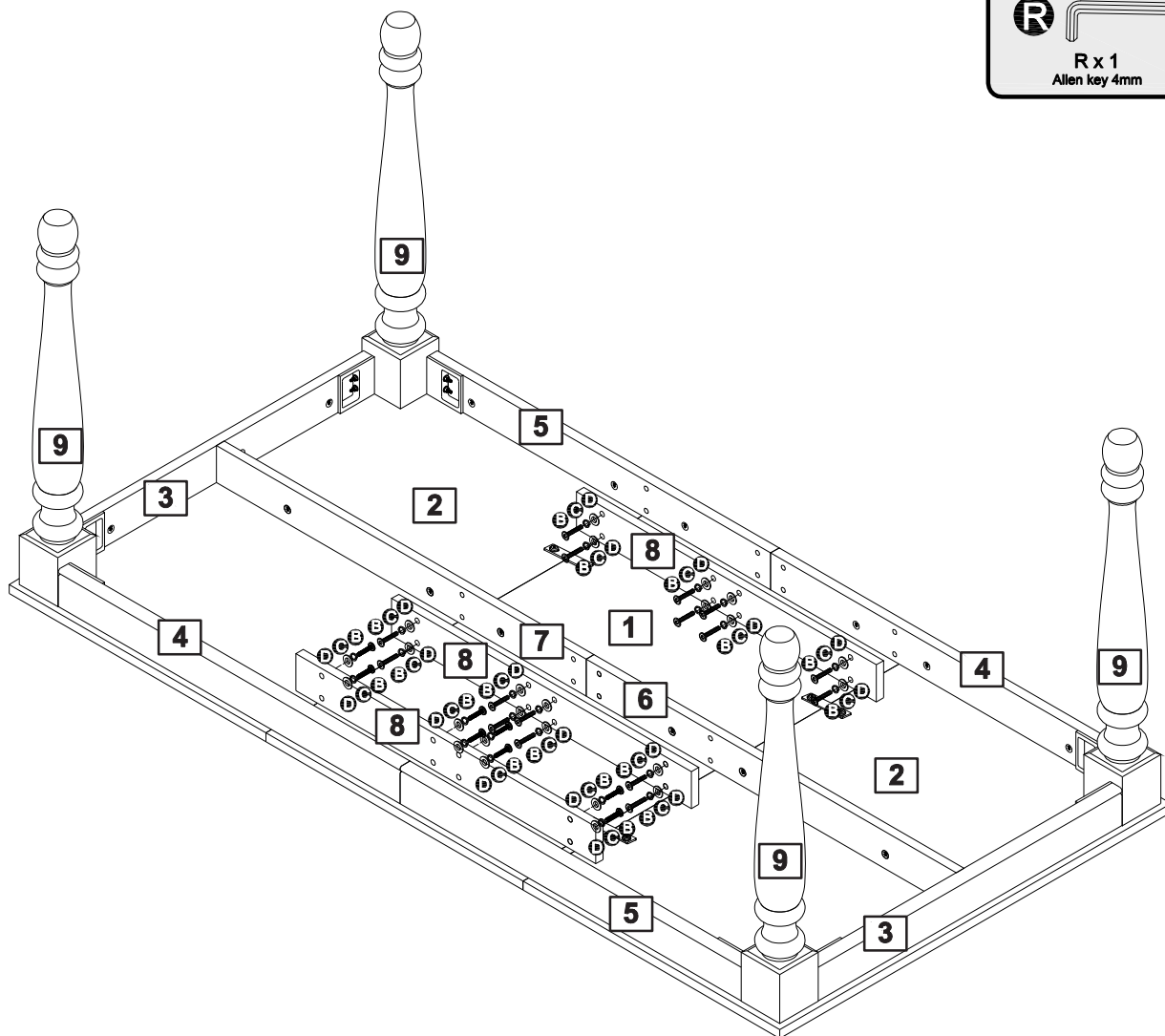

# Assembly Instructions

## Step 11

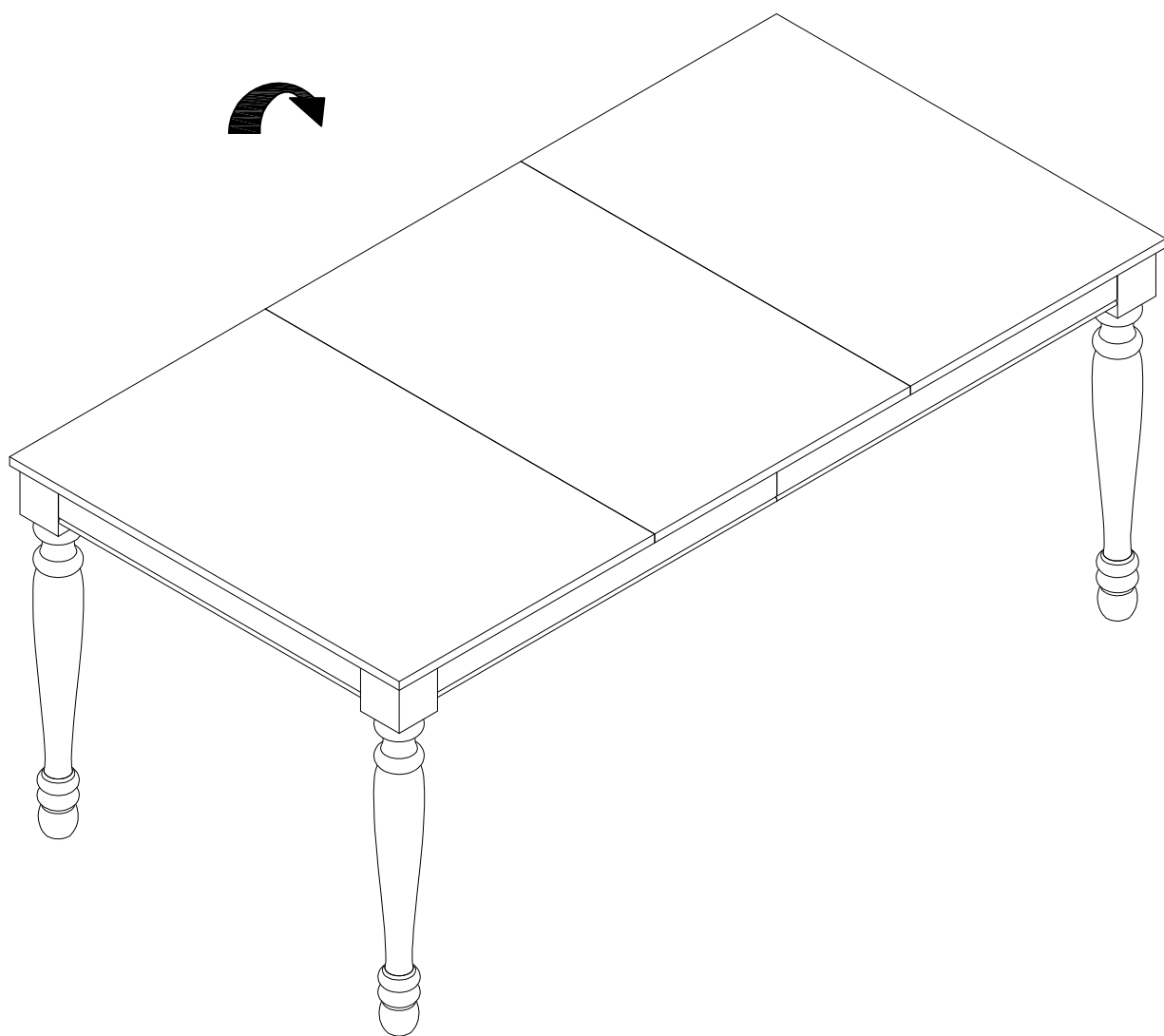

# Assembly Instructions

## Step 12

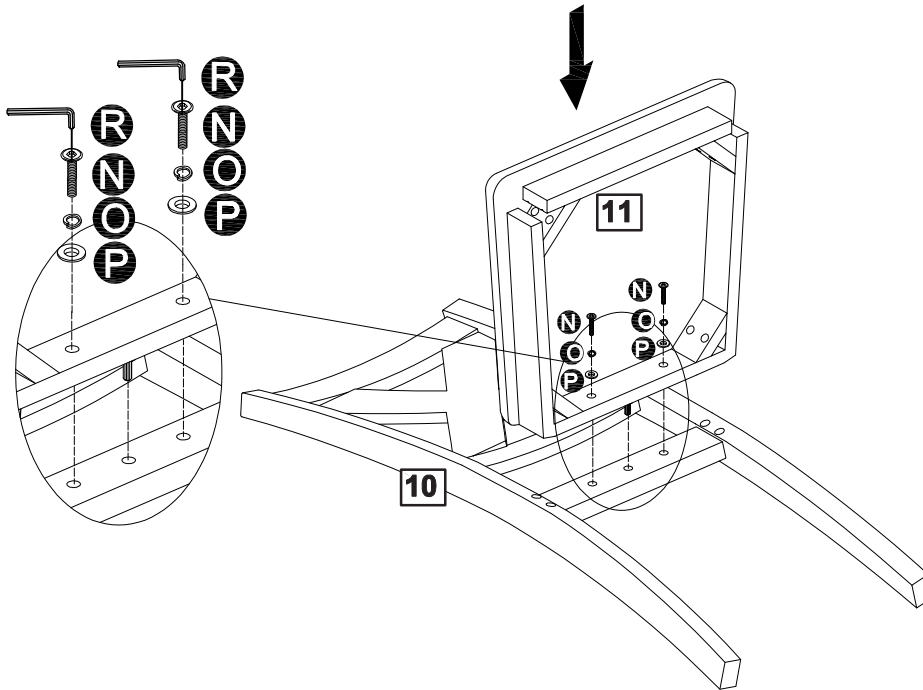

N x 2  
1/4"x32mm Bolt



O x 2  
1/4" Lock washer



P x 2  
1/4"x16mm Flat washer



R x 1  
Allen key 4mm

## Step 13

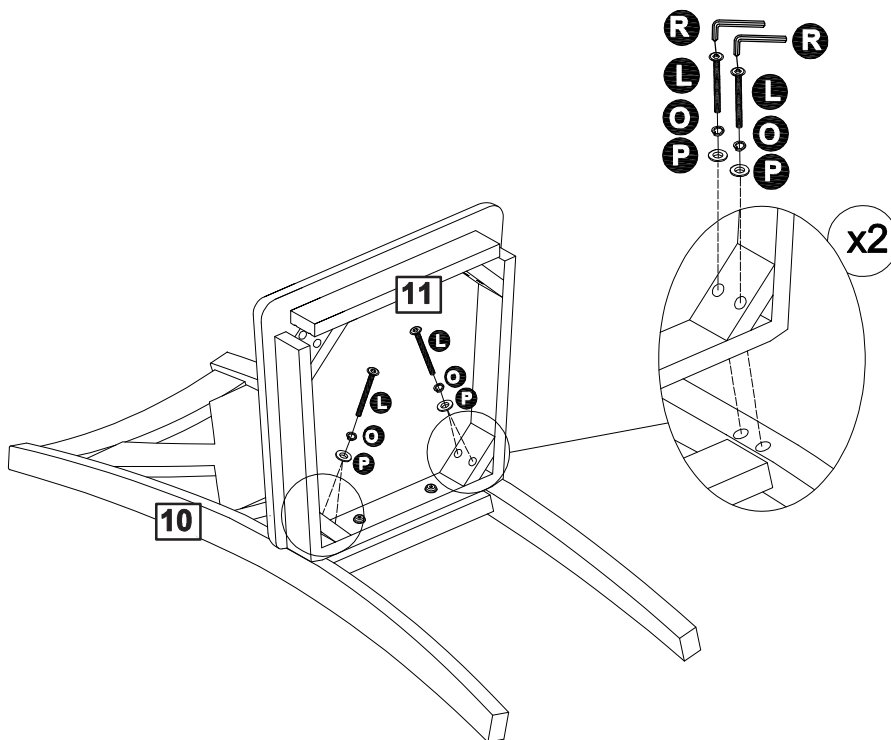

L x 4  
1/4"x76mm Bolt



O x 4  
1/4" Lock washer



P x 4  
1/4"x16mm Flat washer



R x 1  
Allen key 4mm

# Assembly Instructions

## Step 14

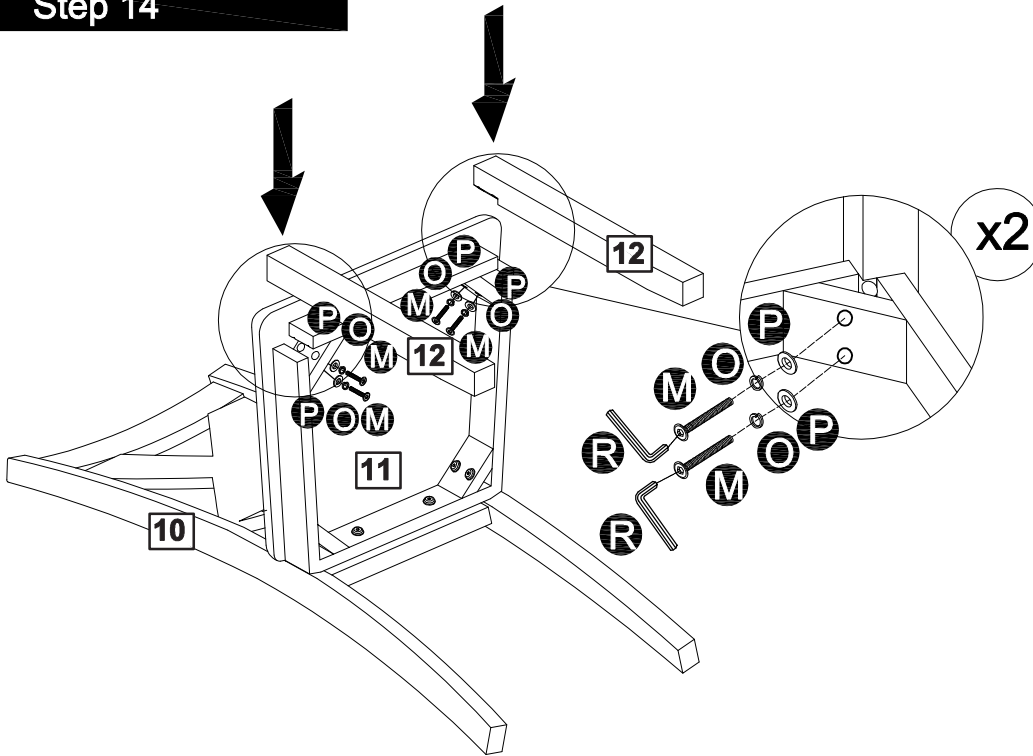

M x 4  
1/4"x60mm Bolt



O x 4  
1/4" Lock washer



P x 4  
1/4"x16mm Flat washer



R x 1  
Allen key 4mm

## Step 15

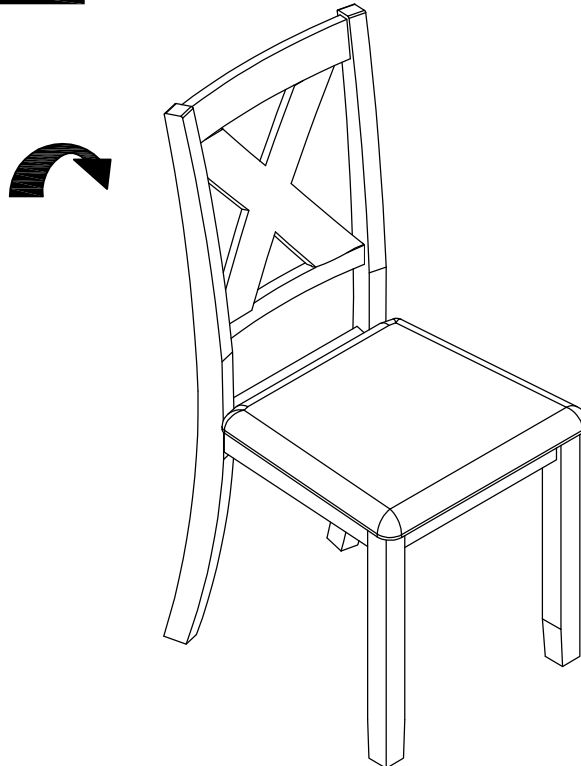

x4



# Assembly Instructions

## Step 16

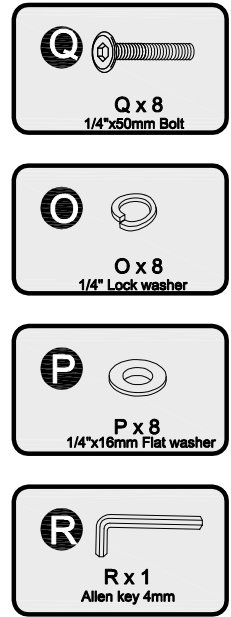
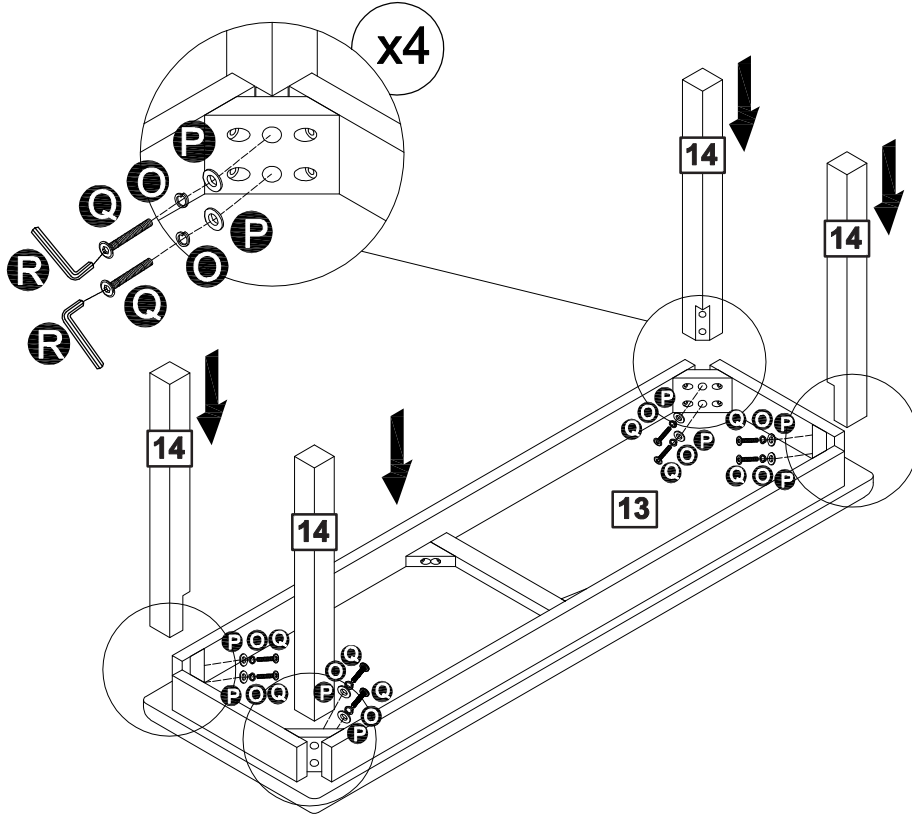

## Step 17

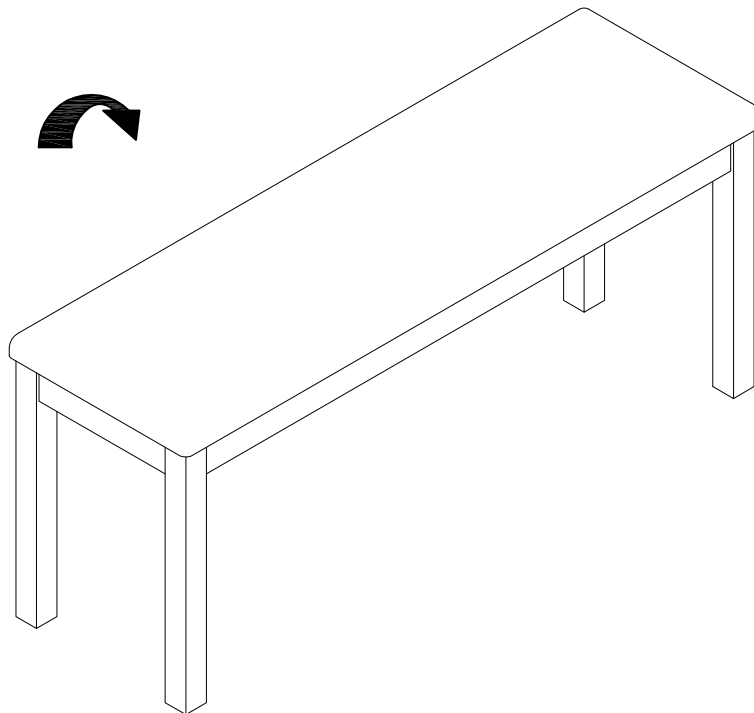

# Assembly Instructions

## Step 18

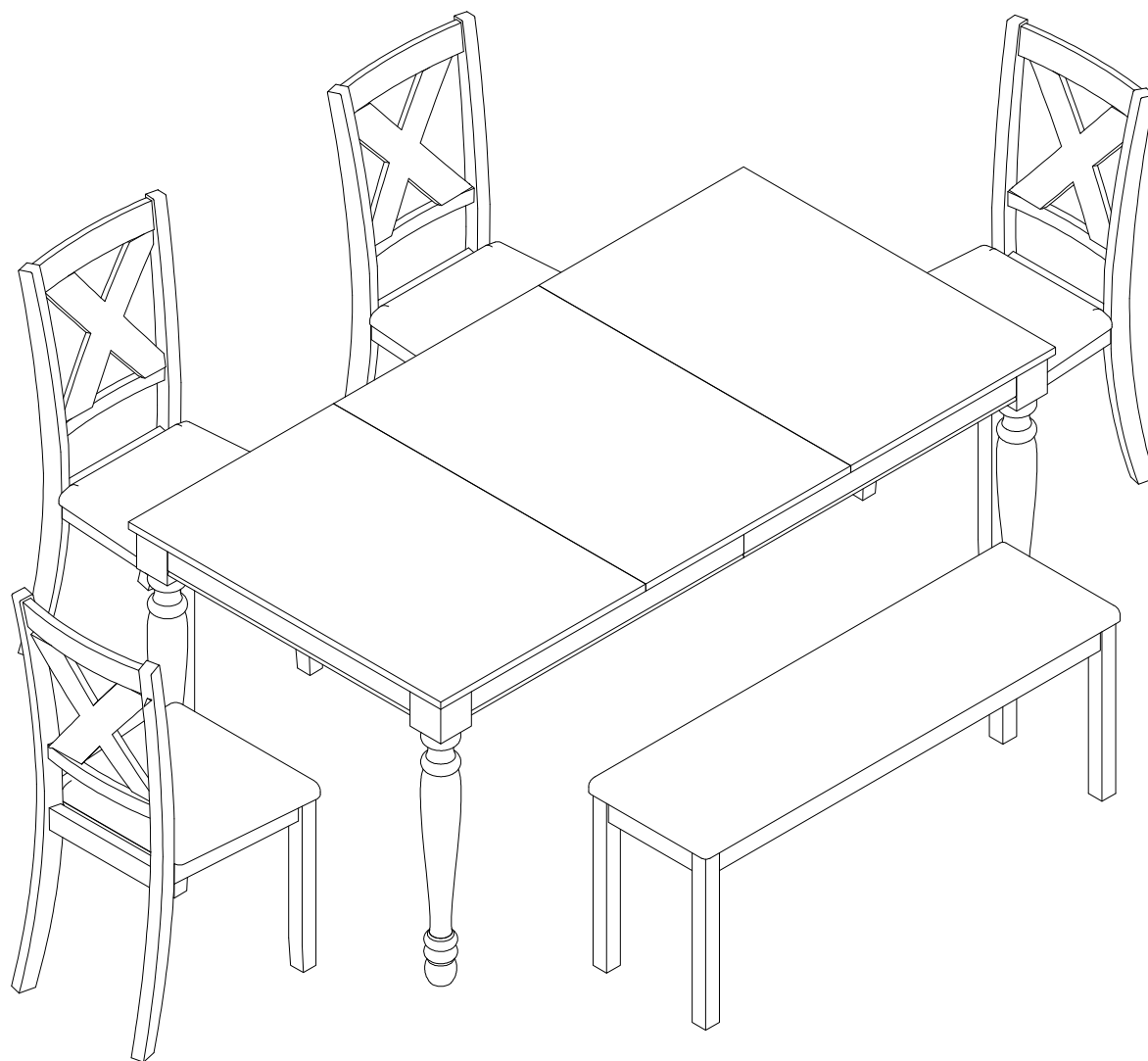

**Installation Complete.**