

Dining table - 4 chairs - 1 bench

Assembly Instructions - Please keep for future reference

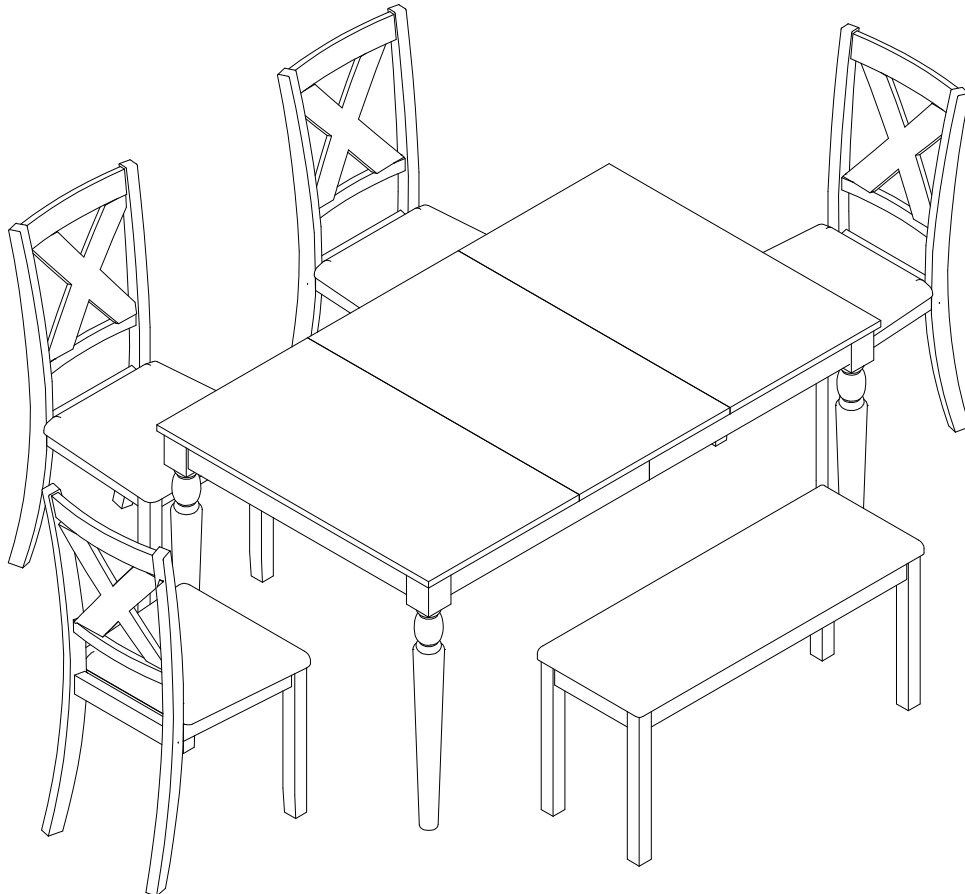

Table Dimensions

Width - 59.9inch
Depth - 36inch
Height - 30inch

Chair Dimensions

Width - 18.3inch
Depth - 22.3inch
Height - 36.6inch

Bench Dimensions

Width - 38inch
Depth - 13.8inch
Height - 19inch

Delivered with TWO PACKAGES with TWO TRACKINGS, may NOT be delivered at the same time.

Any question please feel free to contact us:
support@amer-life.com TEL: (901) 347-2181
We will provide further assistance within 24 hours.

Important – Please read these instructions fully before starting assembly

Seller's Notice:

Our product is packed in separate boxes as shown below, and they might be shipped in different batches. Please wait until you received all the boxes then start the assembly.

Noted: Assembly instruction is only provided in Box1.

The following is the list of components contained in each box.

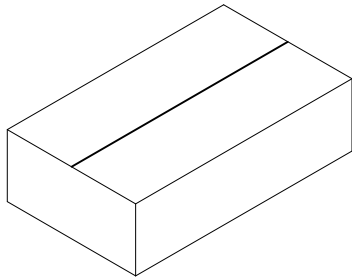

Main structure accessories

1		Center panel	x1
2		Side panel	x2
3		Build up short side	x2
4		Build up 1 long side	x2
5		Build up 2 long side	x2
6		Build up 1 center	x1
7		Build up 2 center	x1
8		Build up connect	x3
9		Table leg	x4
10		Chair seat cushion	x2

HARDWARE

All hardware are in Box 1.

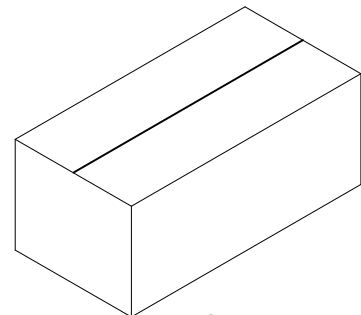

Main structure accessories

10		Chair seat cushion	x2
11		Chair leg	x8
12		Chair back	x4
13		Bench leg	x4
14		Bench seat cushion	x1



Safety and Care Advice

Important – Please read these instructions fully before starting assembly

- Check you have all the components and tools listed on the following pages.
- Remove all fittings from the plastic bags and separate them into their groups.
- Keep children and animals away from the work area, small parts could choke if swallowed.
- Make sure you have enough space to layout the parts before starting.

- During assembly do not stand or put weight on the product, this could cause damage.
- Assemble the item as close to its final position (in the same room) as possible.
- Assemble on a soft level surface to avoid damaging the unit or your floor.
- Parts of the assembly will be easier with 2 people.



- To reduce the likelihood of damaging your product please ensure that your power drill is set on a low torque setting.

Care and maintenance

- Only clean using a damp cloth and mild detergent, do not use bleach or abrasive cleaners.
- From time to time check that there are no loose screws on this unit.
- This product should not be discarded with household waste. Take to your local authority waste disposal centre.

Handy Hints

- Assemble all parts and bolts loosely during assembly, only once the product is complete should you fully tighten the bolts
- Regularly check and ensure that all bolts and fittings are tightened properly.

WARNING In order to help prevent overturning – please follow these instructions

To help prevent product toppling over please follow the below steps:-

Use the anti tip strap or wall fixing method provided (if applicable)
Do not allow children to climb or hang on the furniture
Do not open more than one drawer at a time
Do not place heavy items in the top drawers
Do not place heavy items on top of the furniture, unless the furniture has been designed for this purpose

please note that only the anti tip strap is provided.

You will need to provide wall plugs and screws applicable for your wall type

Components - Panels

Please check you have all the panels listed below

Table

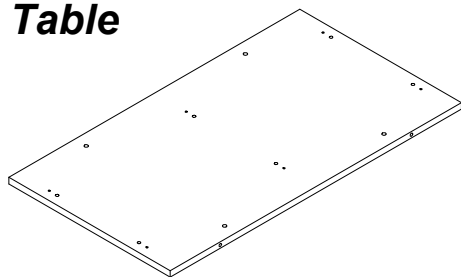

1 (914x507x18mm) X 1

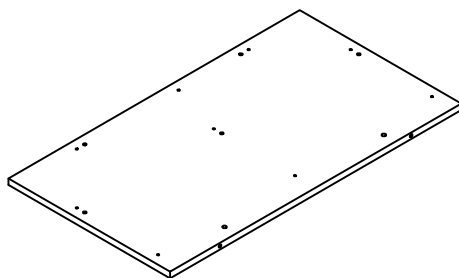

2 (914x506x18mm) X 2

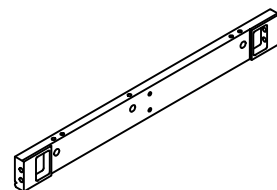

3 (740x75x23mm) X 2

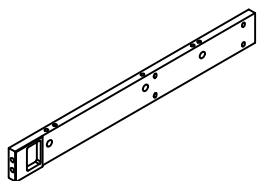

4 (673x75x23mm) X 2

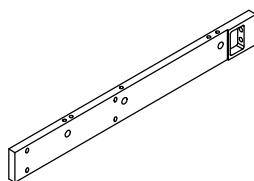

5 (748x75x35mm) X 2

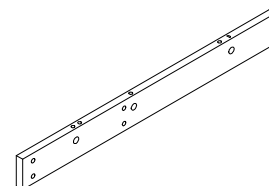

6 (724x75x18mm) X 1

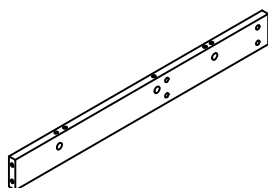

7 (724x75x18mm) X 1

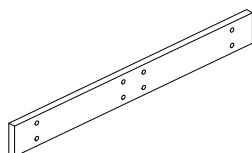

8 (700x75x18mm) X 3



9 (76x75x742mm) X 4

Chair X4

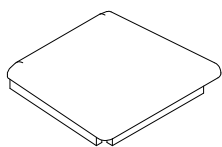

10 (430x395x95mm) X 1



11 (40x40x430mm) X 2



12 (930x465x115mm) X 1

Bench



13 (40x40x440mm) X 4

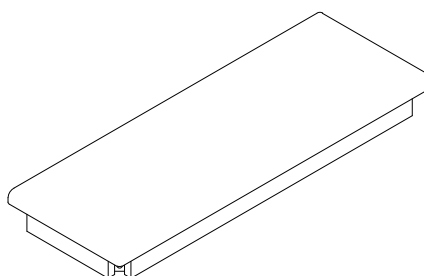













14 (965x360x102mm) X 1

Components - Fittings



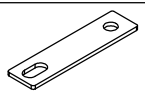



Please check you have all the hardware listed below

Note: The quantities below are the correct amount to complete the assembly. In some cases more fittings may be supplied than are required.





Table

A  1/4"x15mm Bolt x 8	B  1/4"x32mm Bolt x 24	C  1/4" Lock washer x 32
D  1/4"x16mm Flat washer x 32	E  Male Camlock x 24	F  Female Camlock x 24
G  5/16"x80mm Bolt x 16	H  5/16"x16mm Flat washer x 16	I  5/16" Nut x 16
J  Mounting plate metal x 4	K  Ø8x30mm Dowel x 24	R  Allen key 4mm x 1
S  Allen wrench x 1		

Chair X4

L  1/4"x76mm Bolt x 4	M  1/4"x60mm Bolt x 4	N  1/4"x32mm Bolt x 2
O  1/4" Lock washer x 10	P  1/4"x16mm Flat washer x 10	R  Allen key 4mm x 1

Bench

Q  1/4"x50mm Bolt x 8	O  1/4" Lock washer x 8	P  1/4"x16mm Flat washer x 8	R  Allen key 4mm x 1
--	--	--	---

Tools required

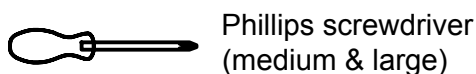

Ruler - Use this ruler to help correctly identify the screws

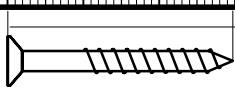
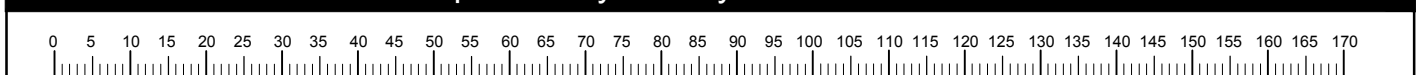

The screws length is measured from the head to the point (30mm screw shown).

Using Camlocks

Step 1

Connect the male camlock as directed in the assembly instructions using a screwdriver.

1

DO NOT OVER TIGHTEN.
NE PAS SERRER EXCESSIVEMENT.

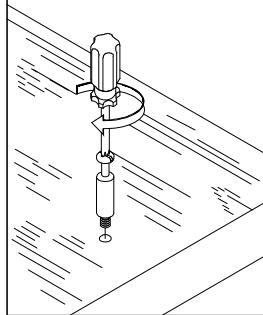

Step 2

Push the male camlock into the entry hole.

2

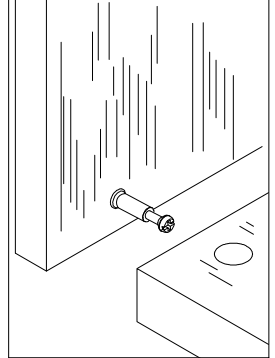

Step 3

Insert the female camlock as shown in the instruction.

Note: ensure that the arrow on the top of the camlock points towards the entry hole for the male camlock.

3

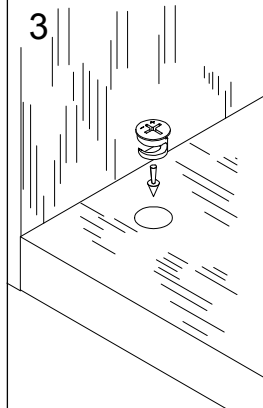

Step 4

Turn the female camlock clockwise with a screwdriver.

You should feel a click when the camlock is locked in place.

The joint is now secure.

4

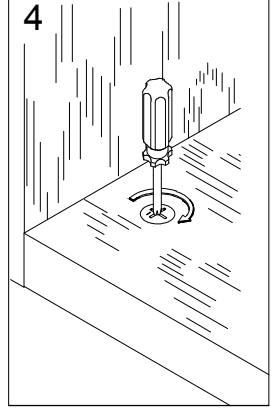

Assembly Instructions

Table

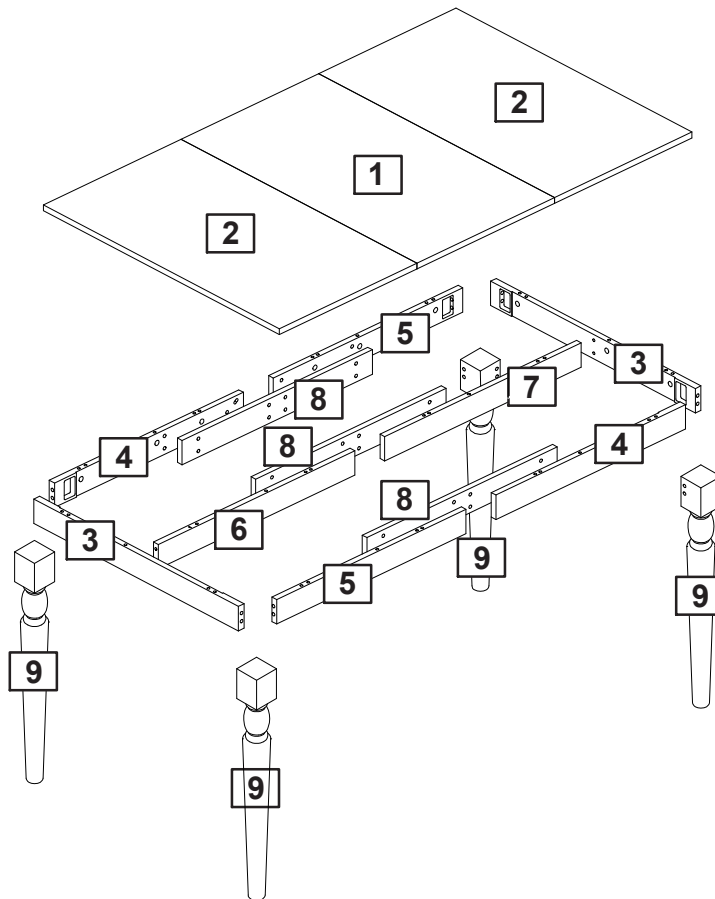

Chair X4

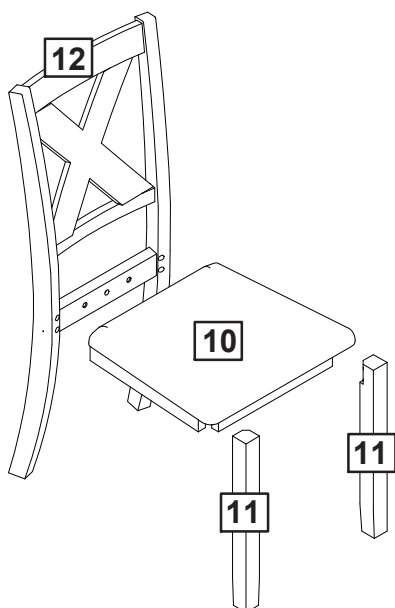

Bench

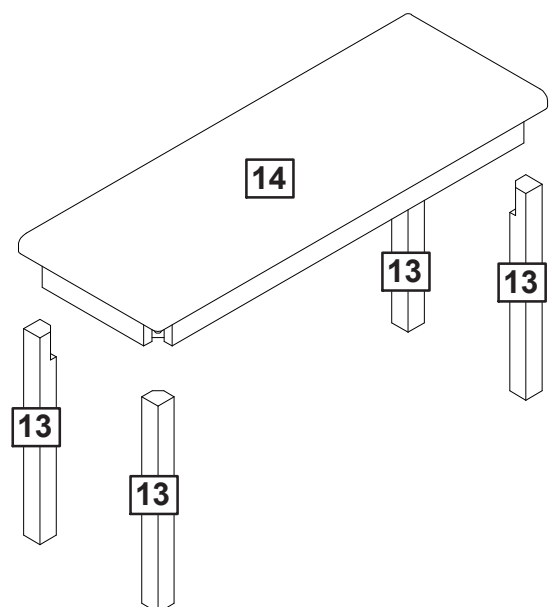

Assembly Instructions

Step 1

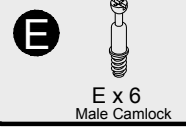
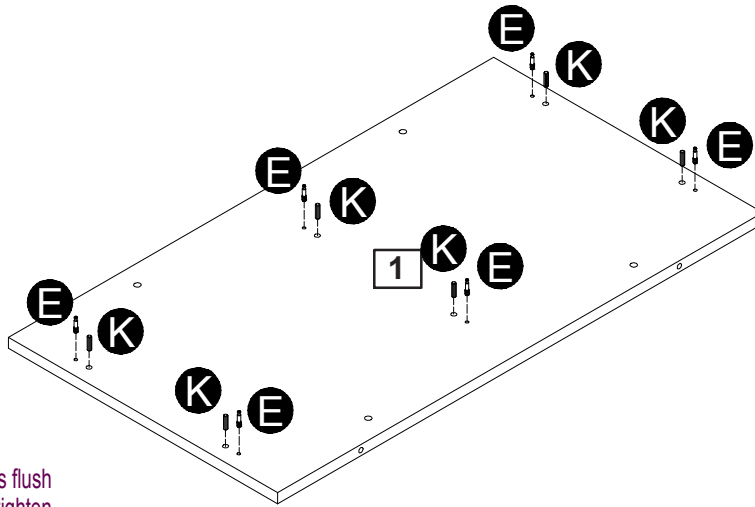

CAM-LOCK
Tighten until shoulder is flush with panel. Do not overtighten or undertighten (see example below)

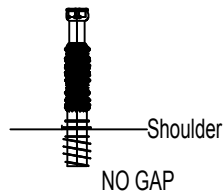
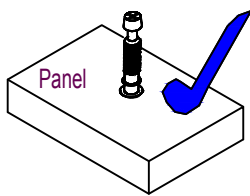
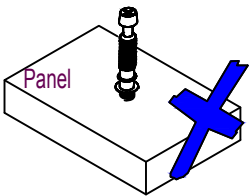

Step 2

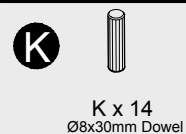
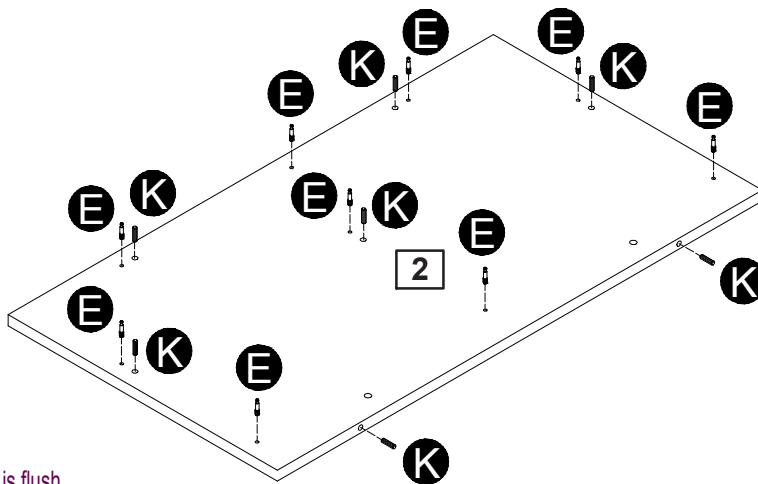

CAM-LOCK
Tighten until shoulder is flush with panel. Do not overtighten or undertighten (see example below)

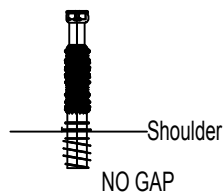
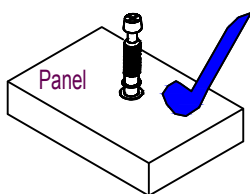
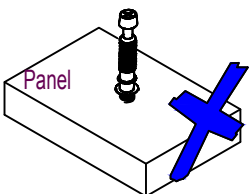

x2

Assembly Instructions

Step 3

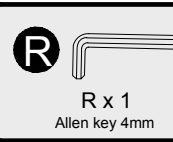
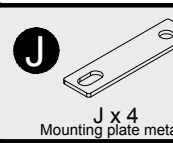
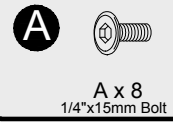
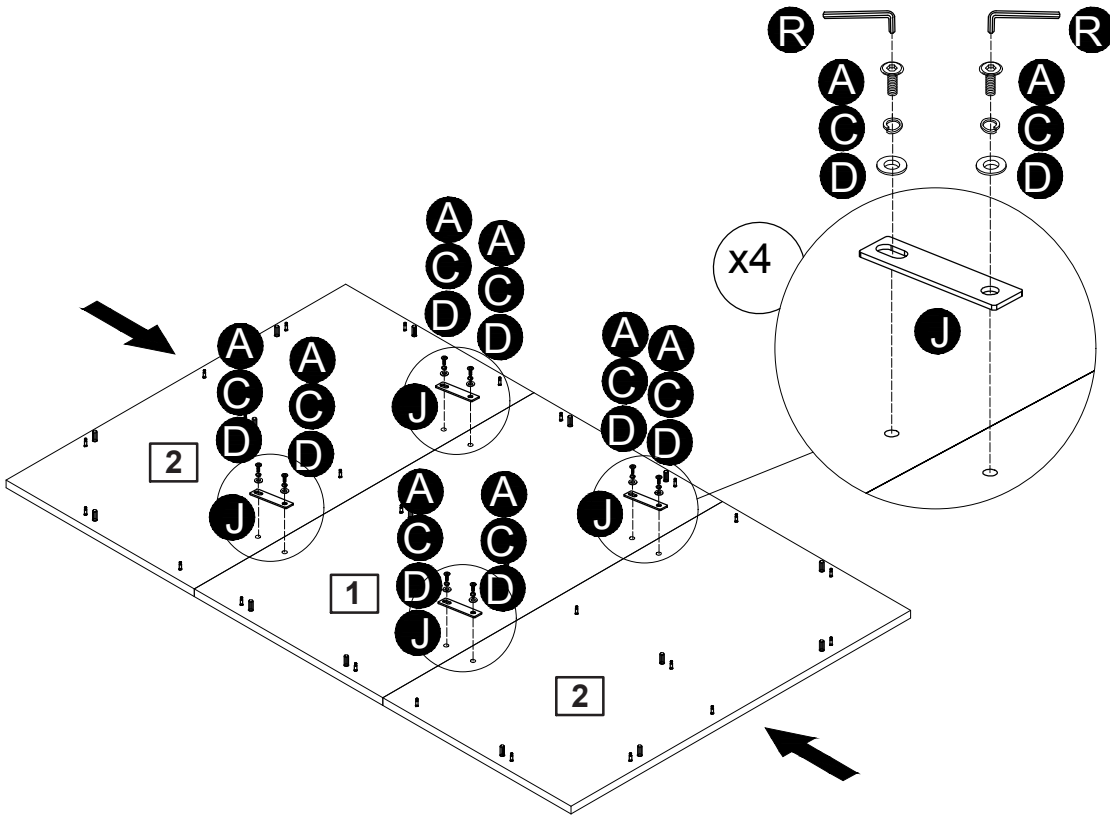

Step 4

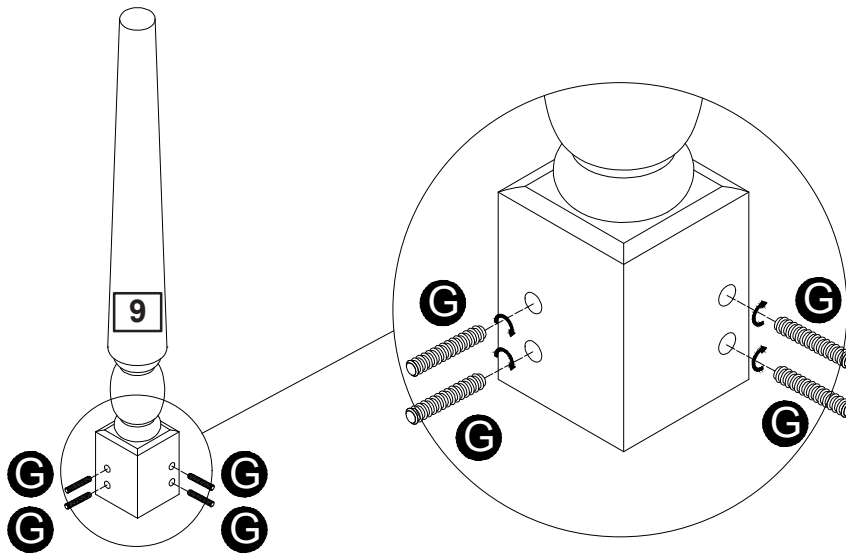

x4

Assembly Instructions

Step 5

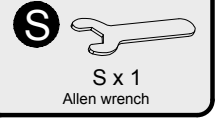
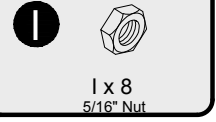
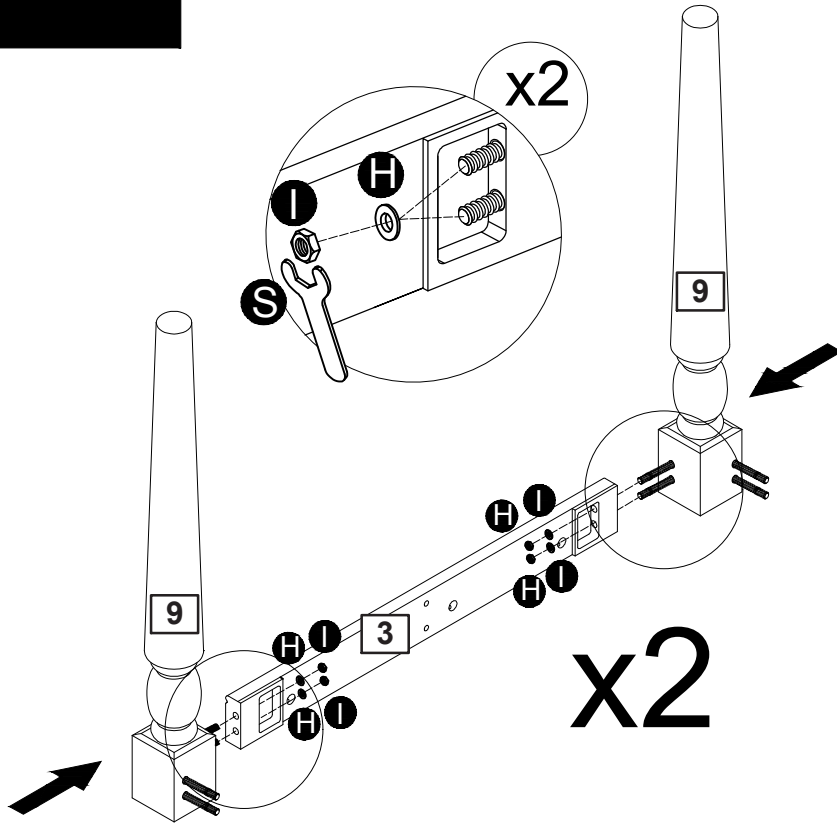

Step 6

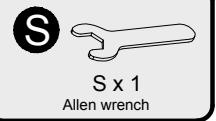
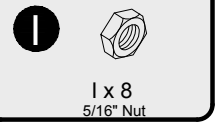
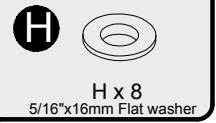
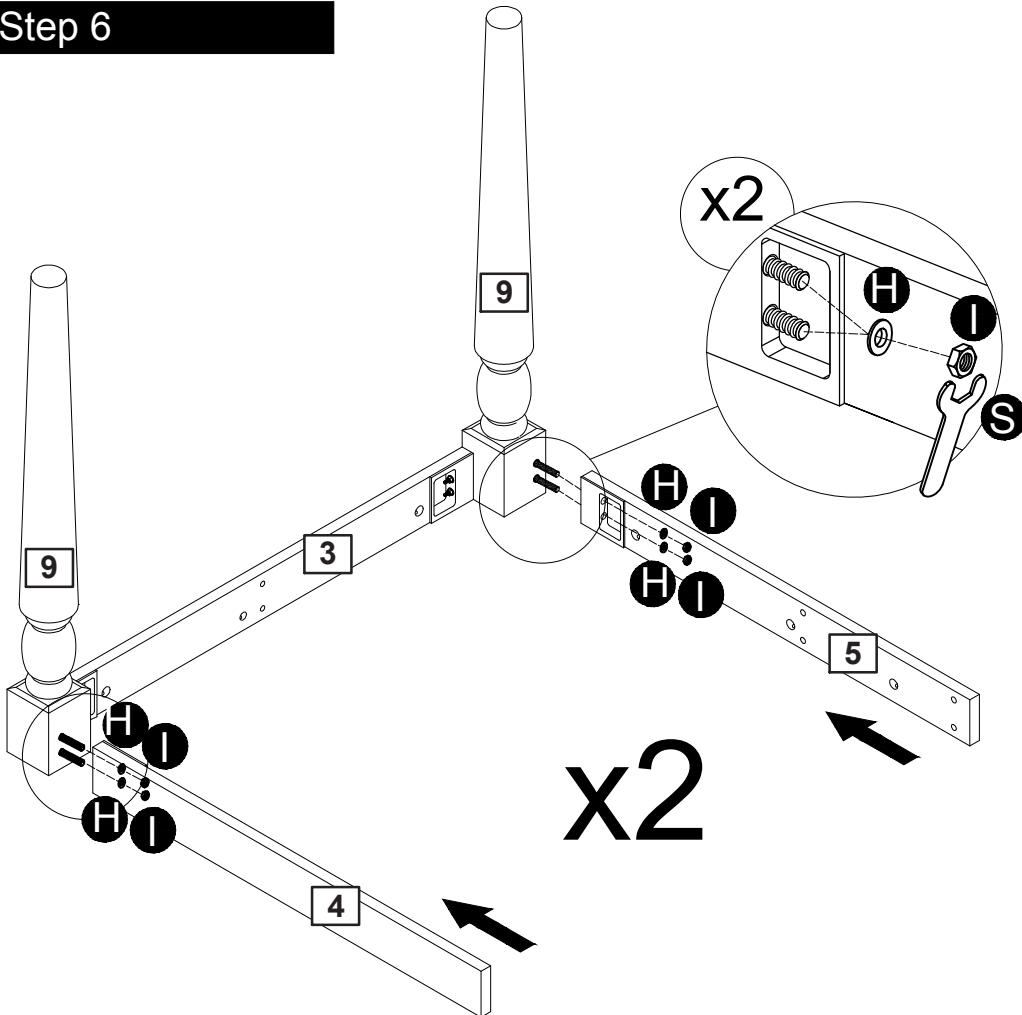

Assembly Instructions

Step 7

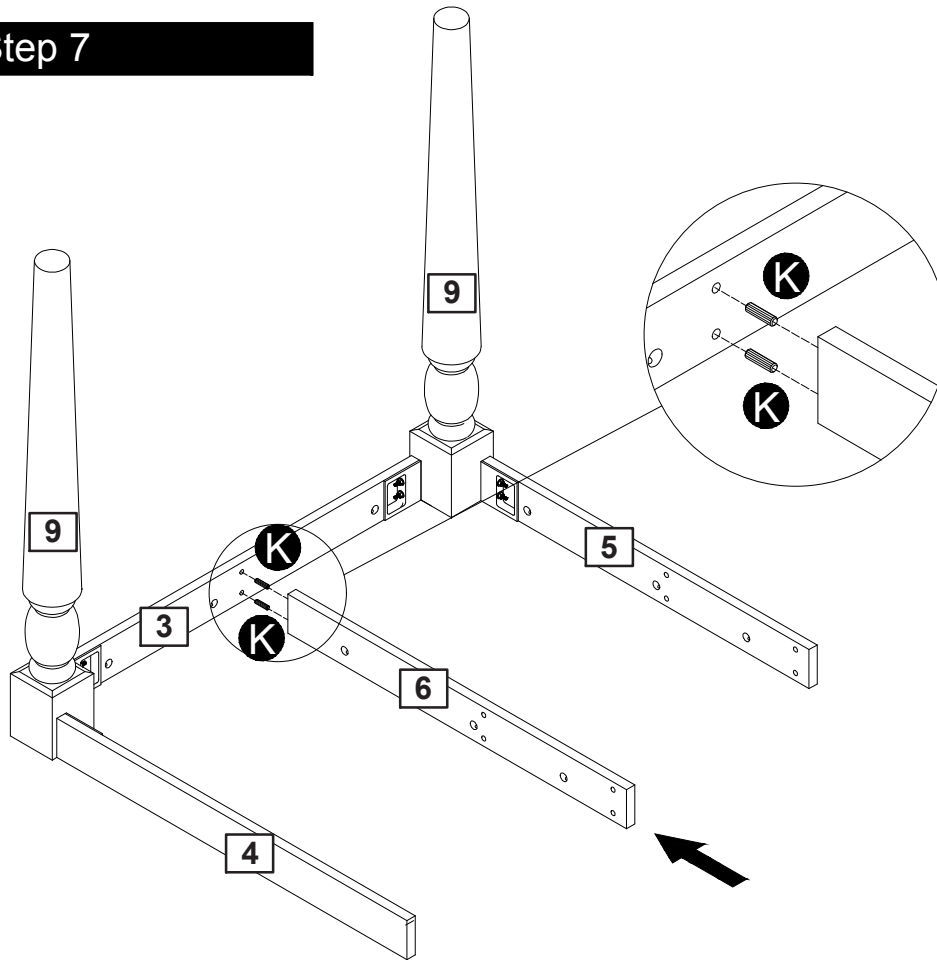

K

K x 2
Ø8x30mm Dowel

Step 8

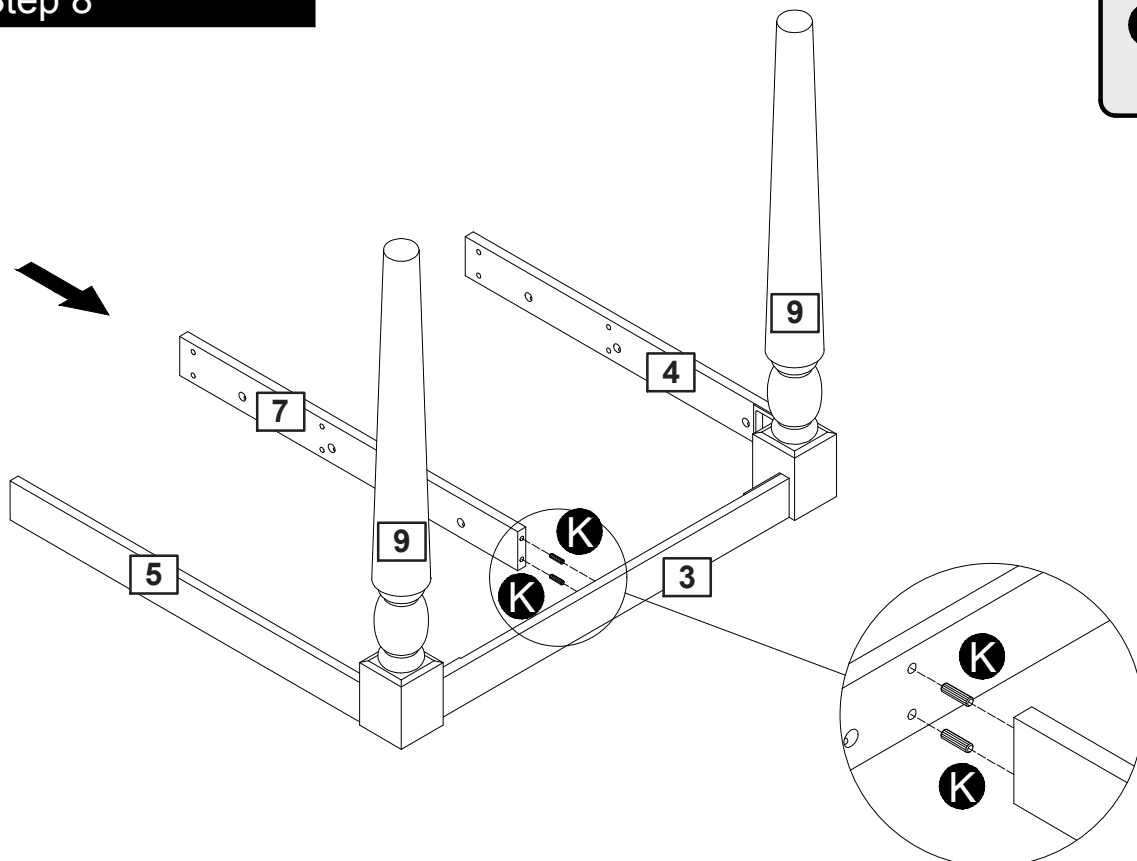

K

K x 2
Ø8x30mm Dowel

Assembly Instructions

Step 9

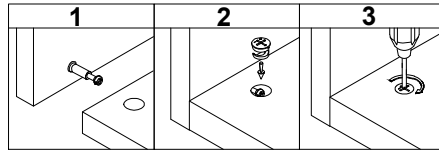

F



F x 24
Female Camlock

CAM-LOCK
Tighten until shoulder is flush with panel. Do not overtighten or undertighten (see example below)

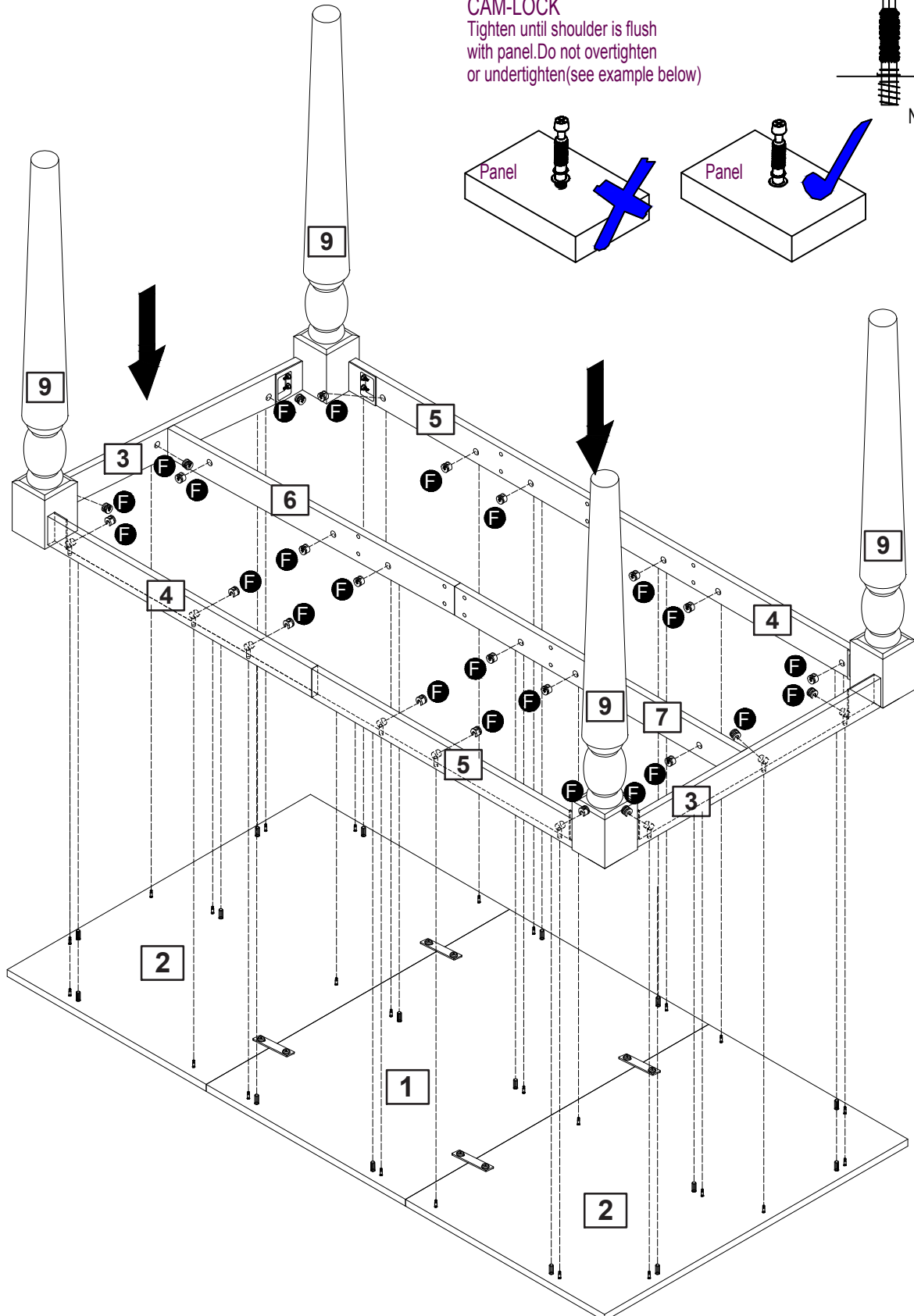
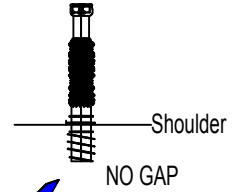
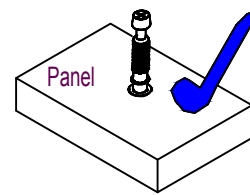
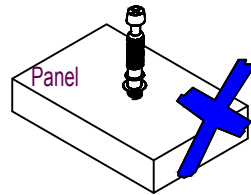

Assembly Instructions

Step 10

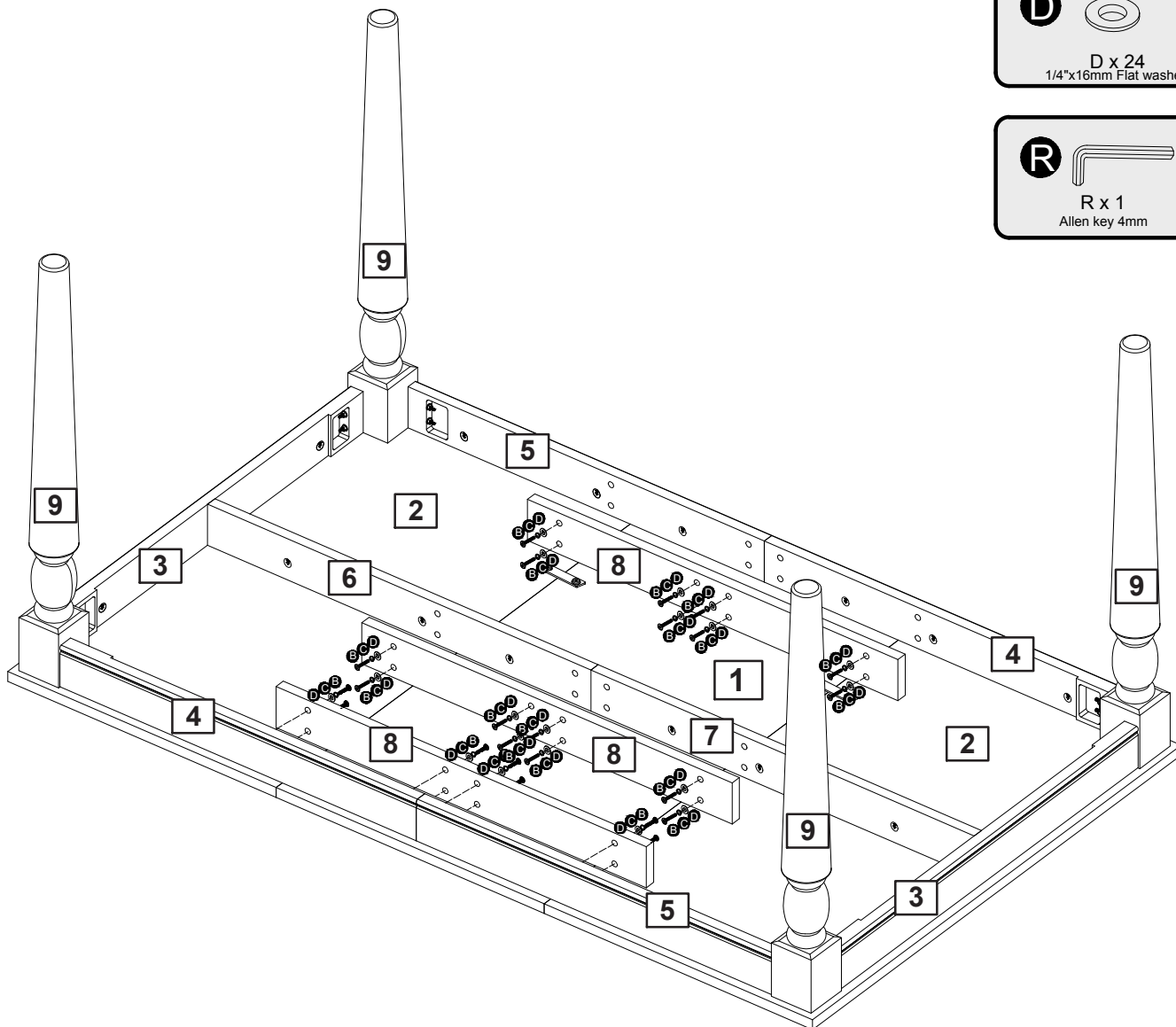
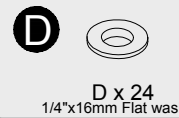
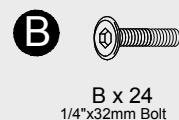

Assembly Instructions

Step 11

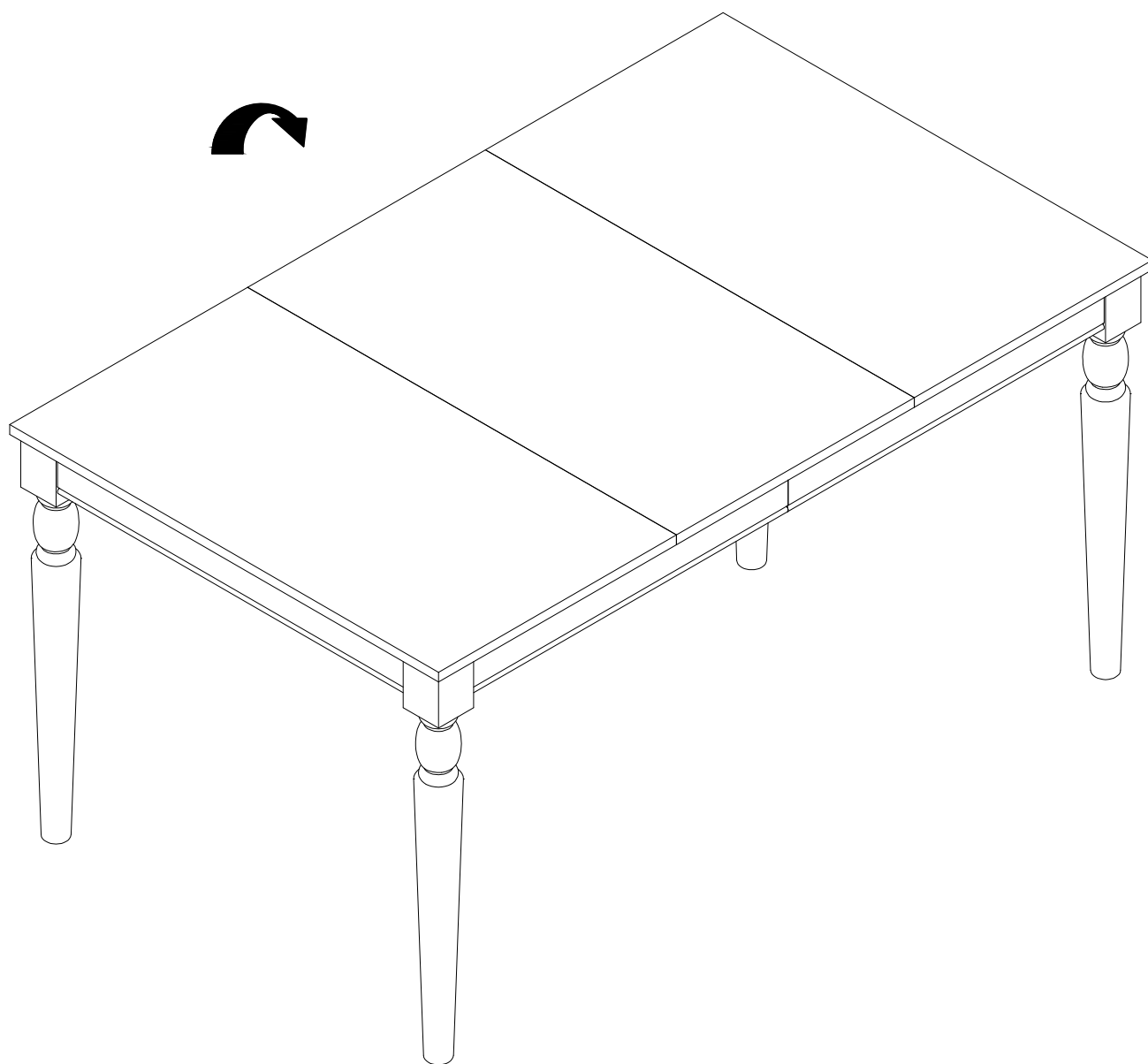

Assembly Instructions

Step 12

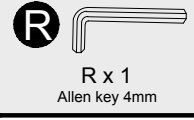
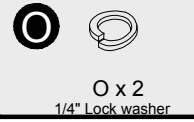
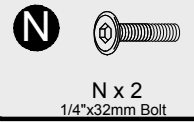
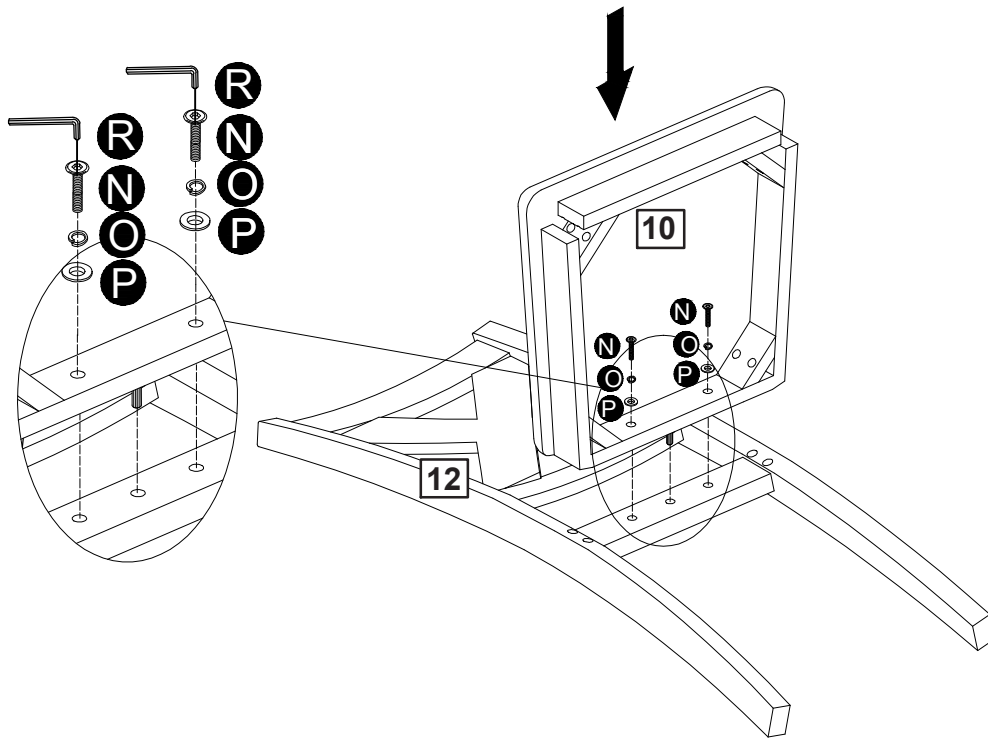

Step 13

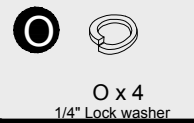
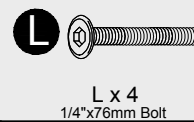
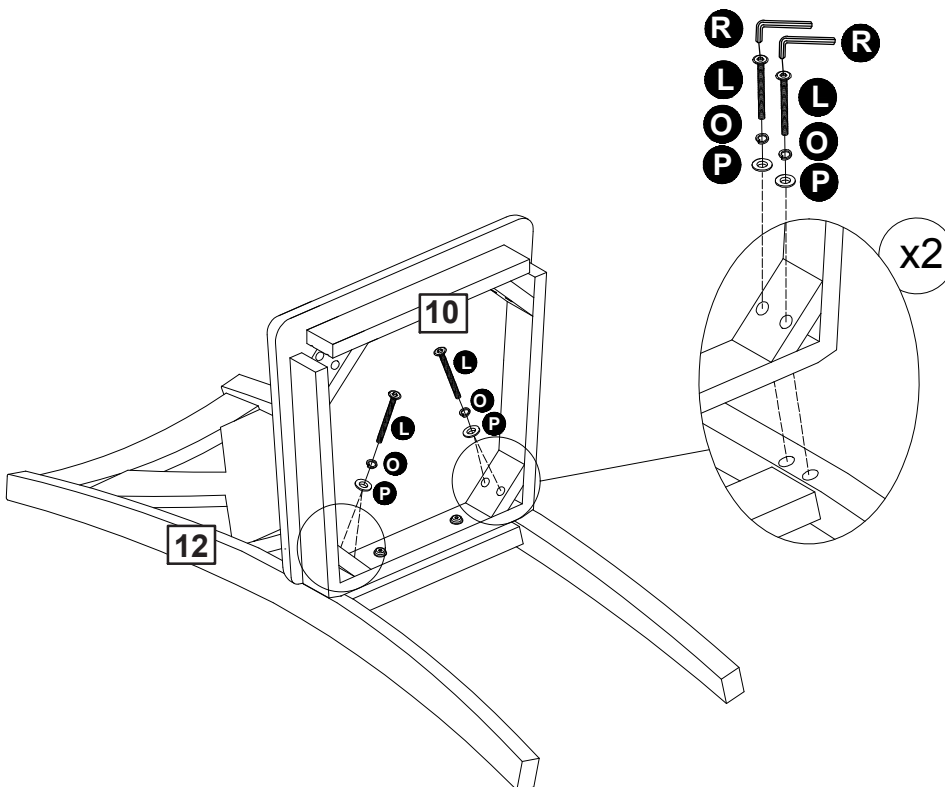

Assembly Instructions

Step 14

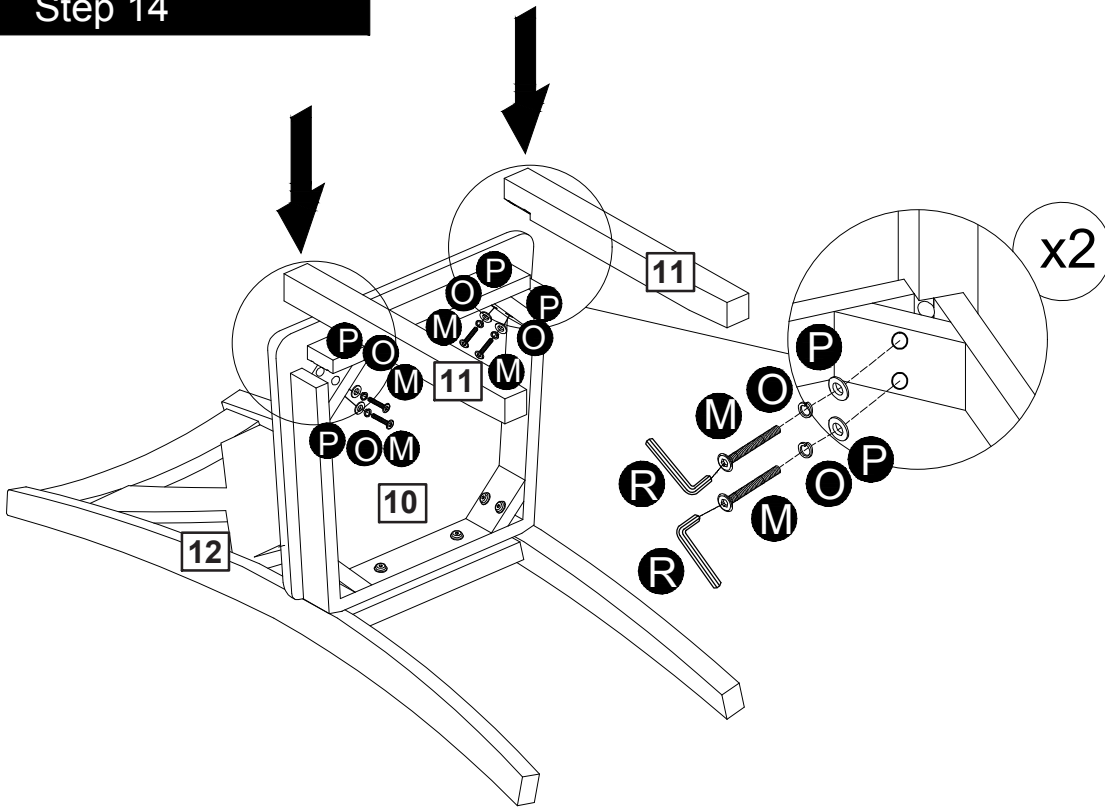

M x 4
1/4"x60mm Bolt



O x 4
1/4" Lock washer



P x 4
1/4"x16mm Flat washer



R x 1
Allen key 4mm

x2

Step 15

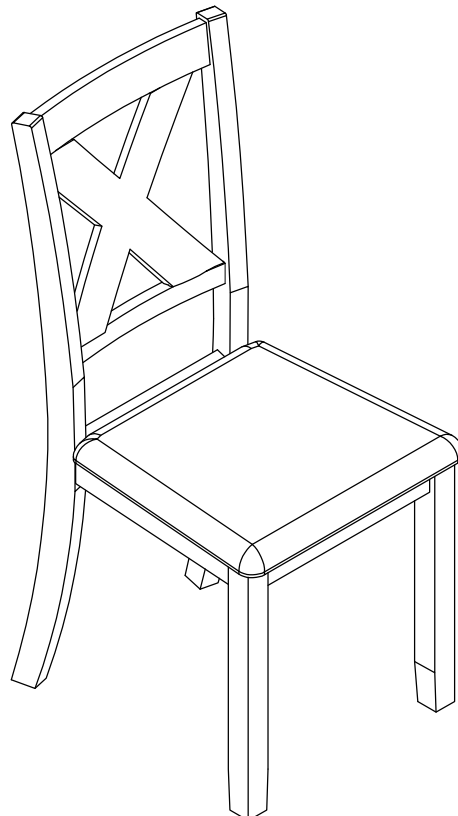

x4

Assembly Instructions

Step 16

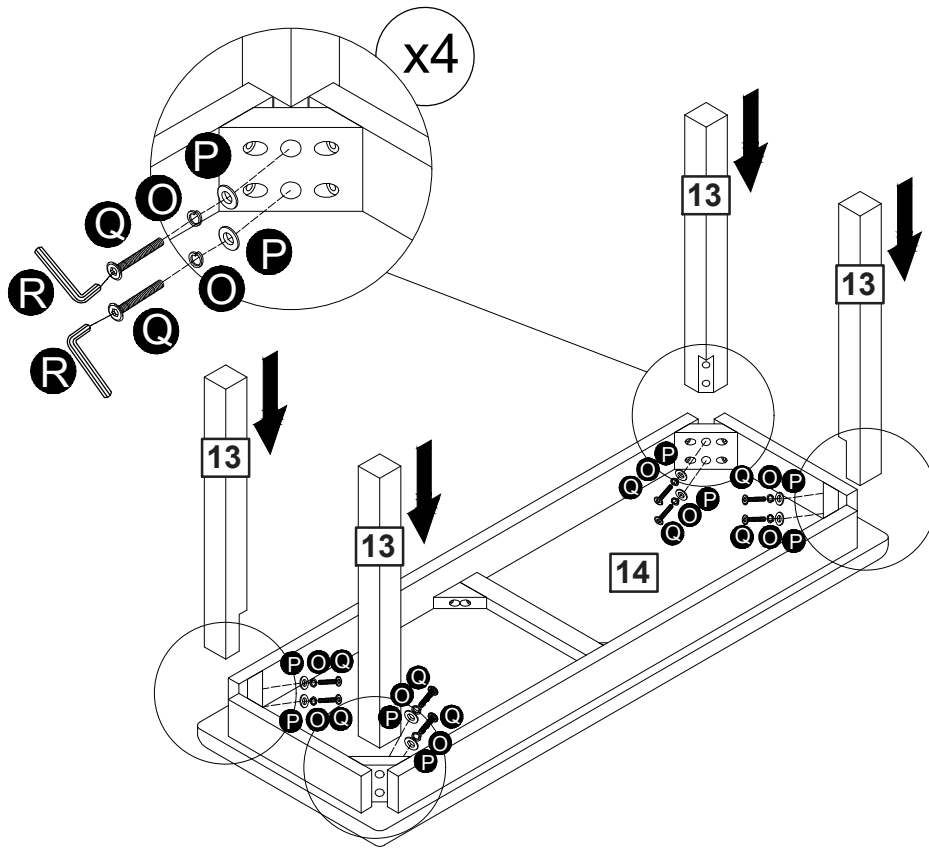

Q x 8
1/4"x50mm Bolt



O x 8
1/4" Lock washer



P x 8
1/4"x16mm Flat washer



R x 1
Allen key 4mm

Step 17

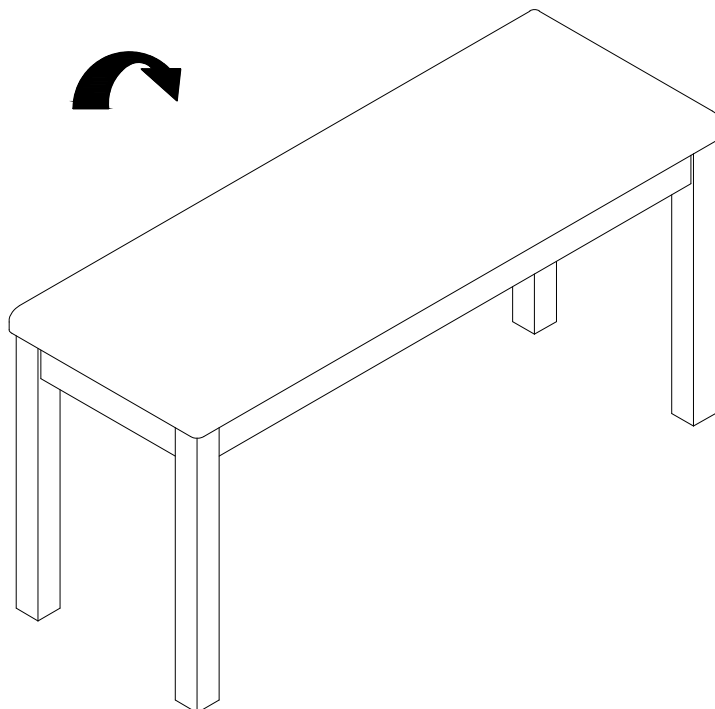

Assembly Instructions

Step 18

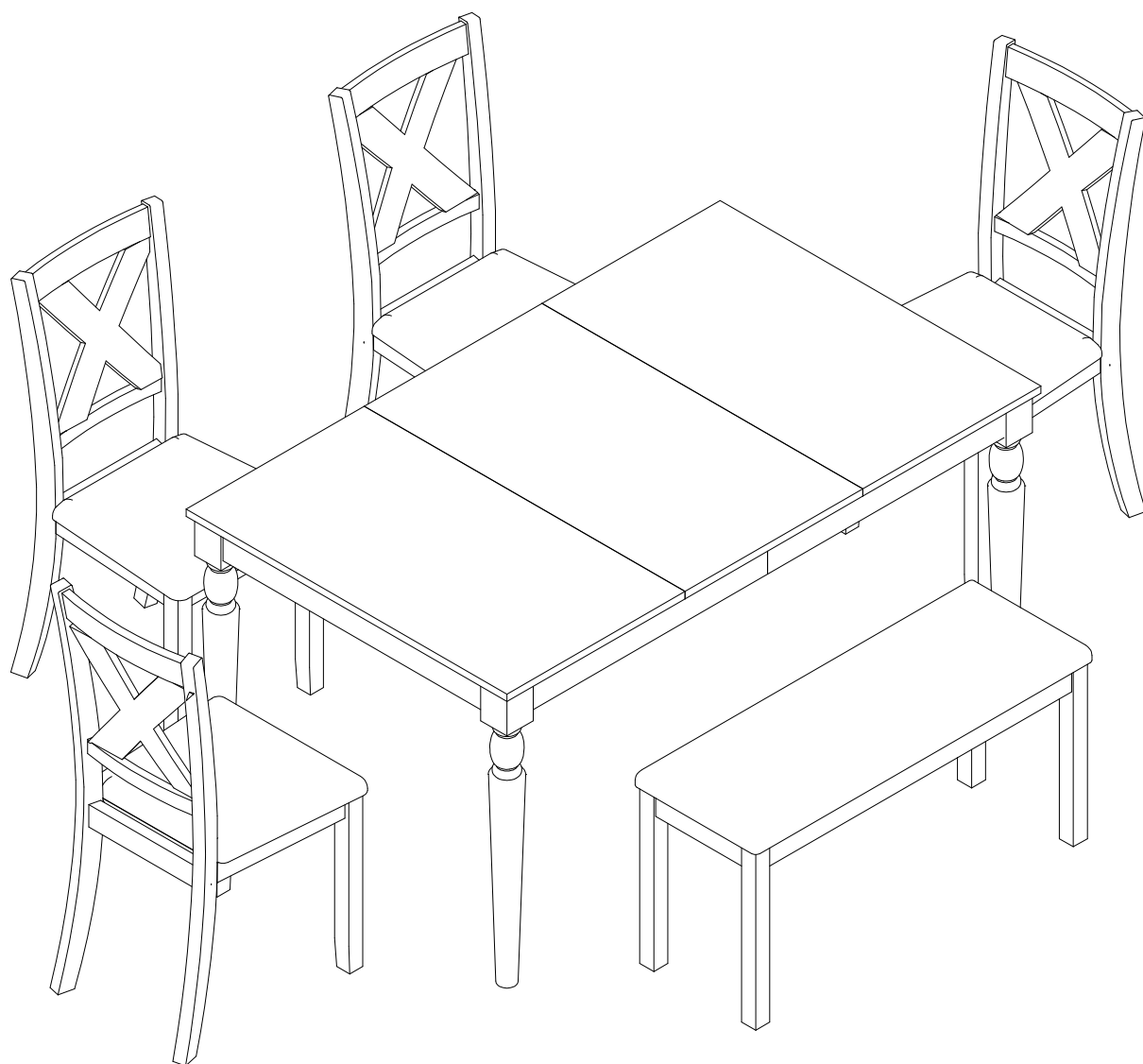

Installation Complete.