

Sofa Assembly Instruction

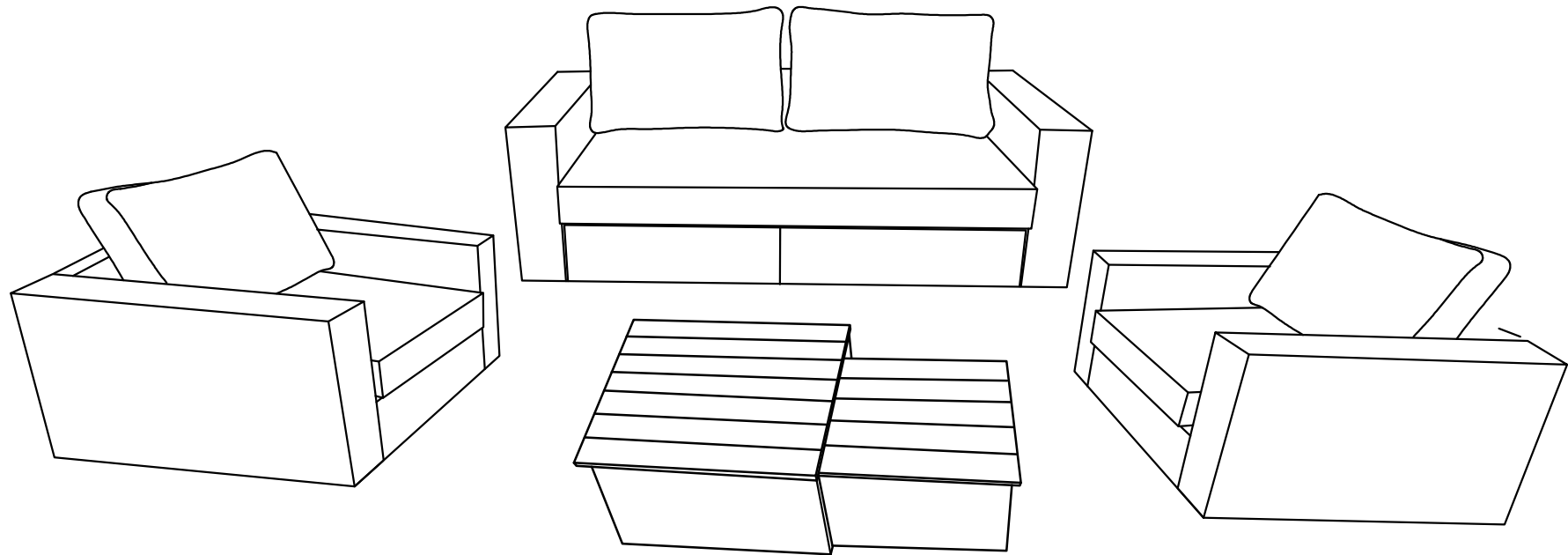

Dear Customer,

After receiving the product, please check all the accessory codes and quantities according to the instruction manual, if there is any omission, please contact us in time. We will provide solutions for you.

If you have any questions, please contact us in time; support@papajet.net

Revision Date:2024109



Safety and Care Advice

Important – Please read these instructions fully before starting assembly

Thanks for your purchase. Before the assembly, please follow the instruction to check if all the spare parts and screws are intact.

- Considering the size and weight of the sofa, we recommend two adults to assemble the sofa, on a carpeted or padded area, in the room that it is intended for. Approximate assembly time: 60 minutes.
- Keep all components and packaging out of reach of children or animals to avoid risk of choking or suffocation.
- Please do not throw away any of the packaging or the instruction until you have checked all the components and hardware and the furniture is fully assembled. Please ensure that the packaging is disposed of in a safe and environmentally friendly way.

Your cushions come vacuum packed and sealed for shipping. To restore the cushion's original shape, follow the steps below.

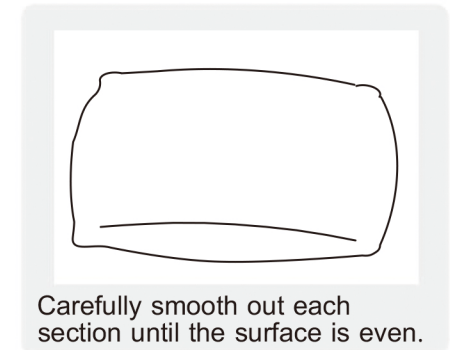
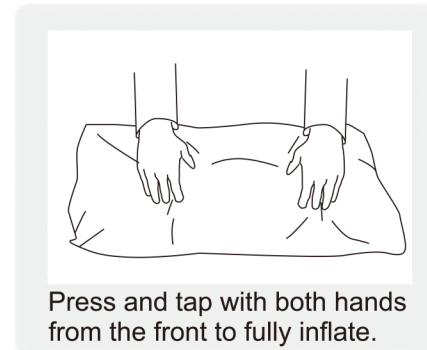
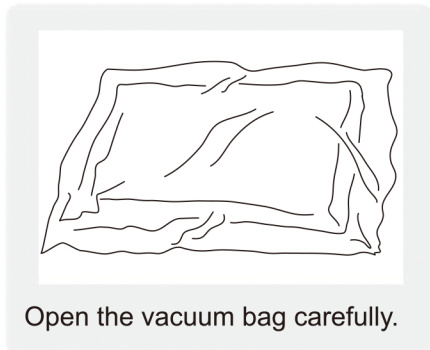

After packing up, place them in somewhere dry and ventilated. After about 72-96hours. It can be restored to the best use condition.

box 1

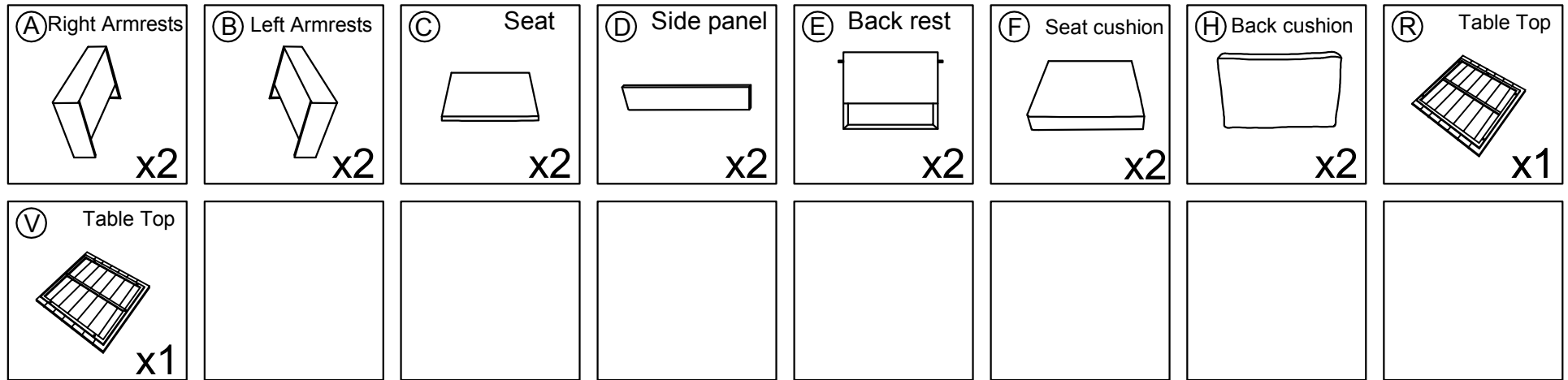

box 2

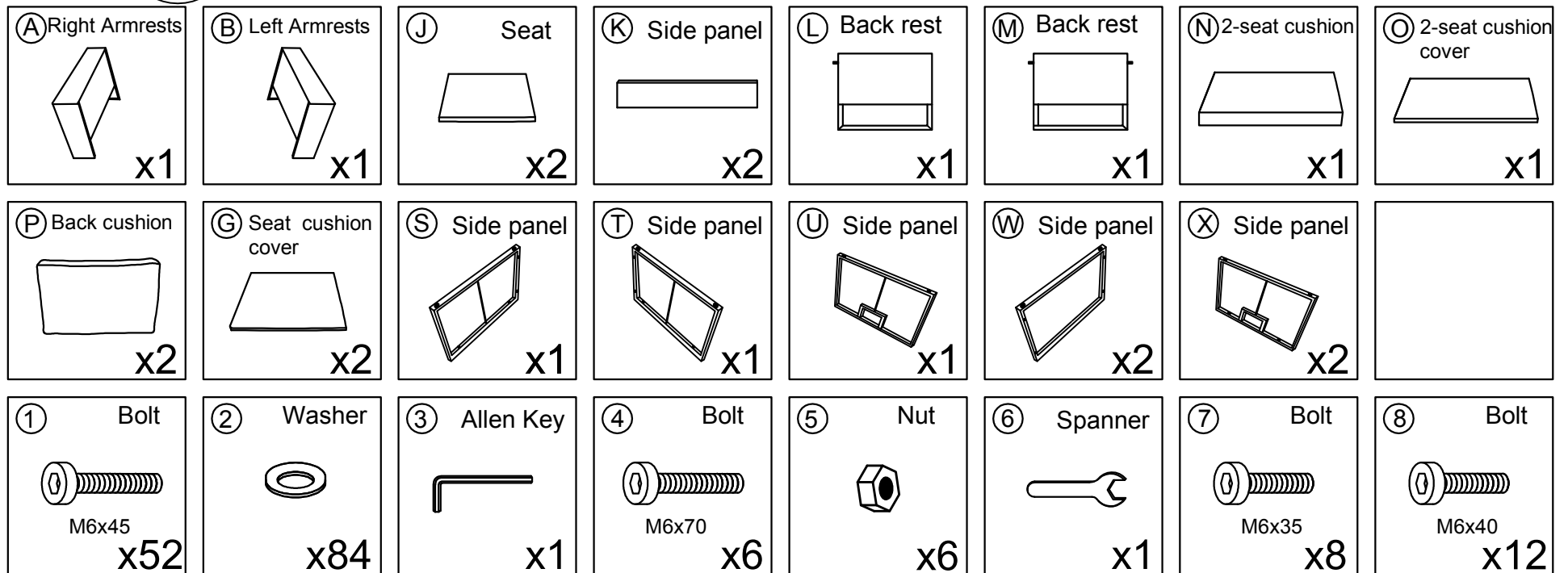

SOFA

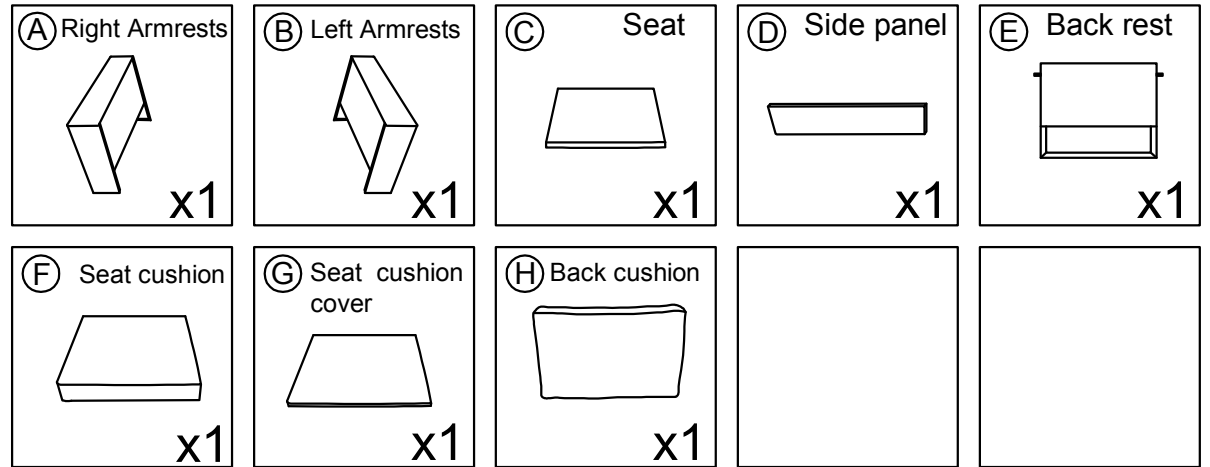
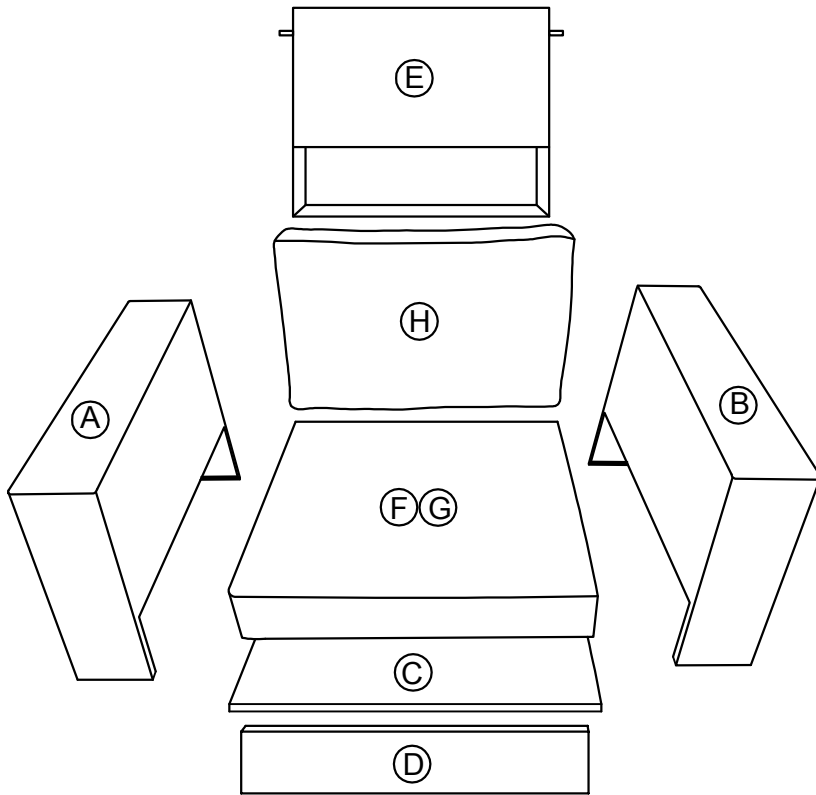



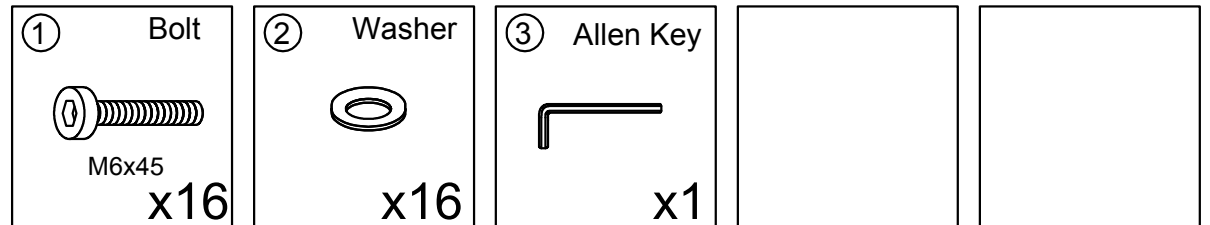

Hardware parts

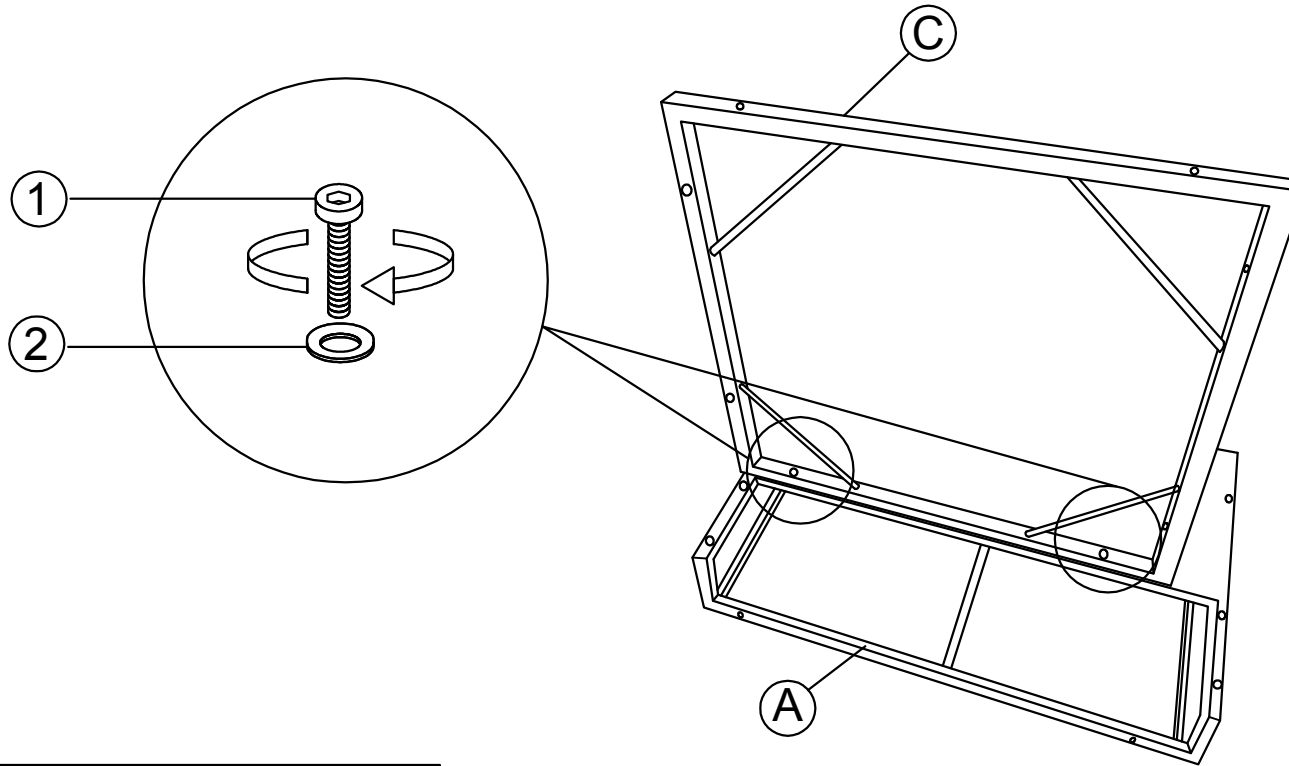

Assembly Instruction

STEP1

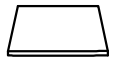

(A) Right Armrests	(C) Seat	(1) Bolt	(2) Washer
			
x1	x1	M6x45 x2	x2

Right



Place the Armrests on the ground before assemble.
Please DO NOT tighten the screws at this step yet. Wait to tighten all the screws until the product is fully installed.

Assembly Instruction

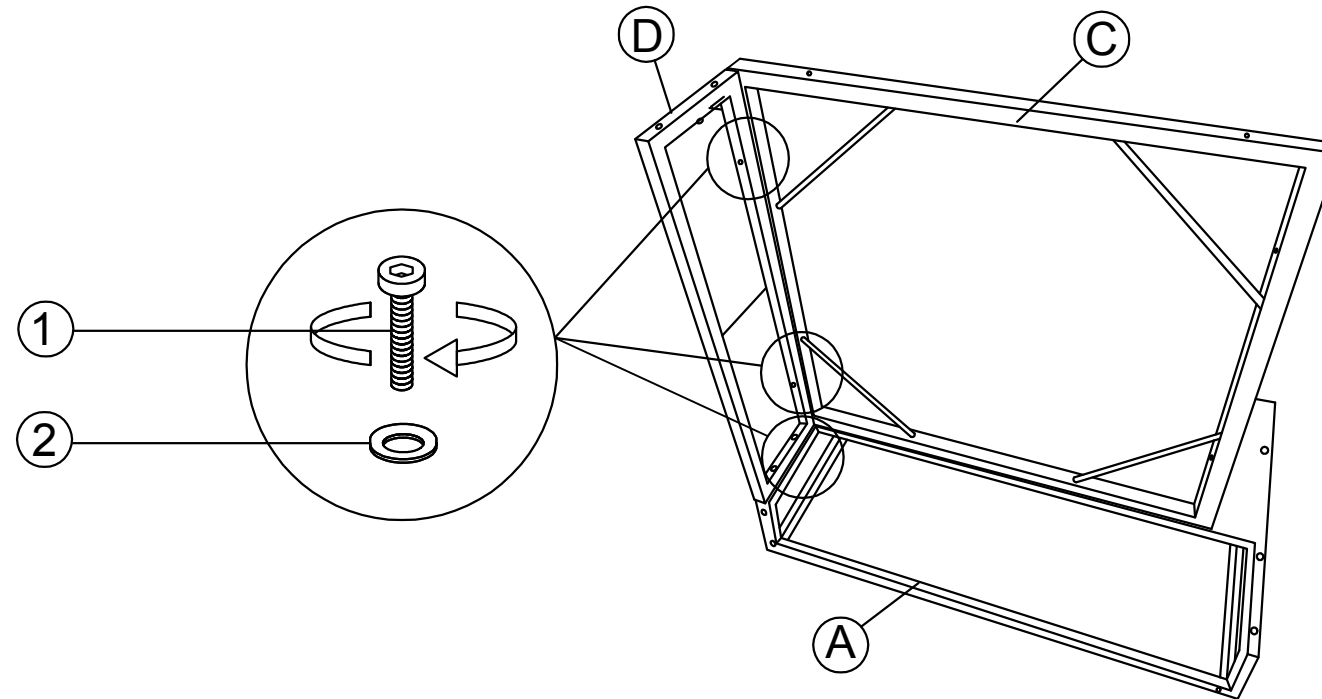
STEP2



Right

④ Side panel	① Bolt	② Washer
		
x1	M6x45 x4	x4

Please DO NOT tighten the screws at this step yet. Wait to tighten all the screws until the product is fully installed.

Assembly Instruction

STEP3

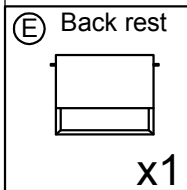
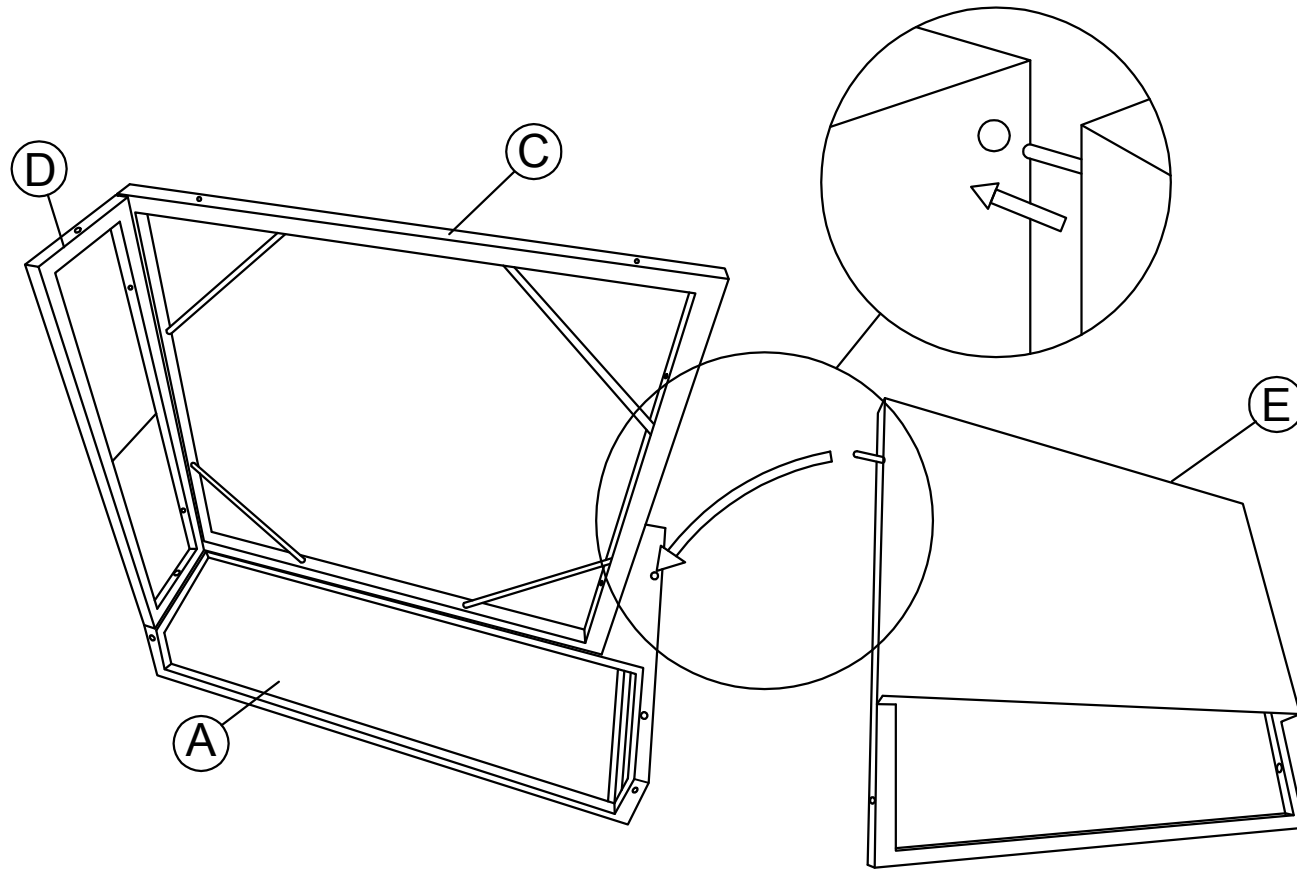



Right

Please DO NOT tighten the screws at this step yet. Wait to tighten all the screws until the product is fully installed.

Assembly Instruction

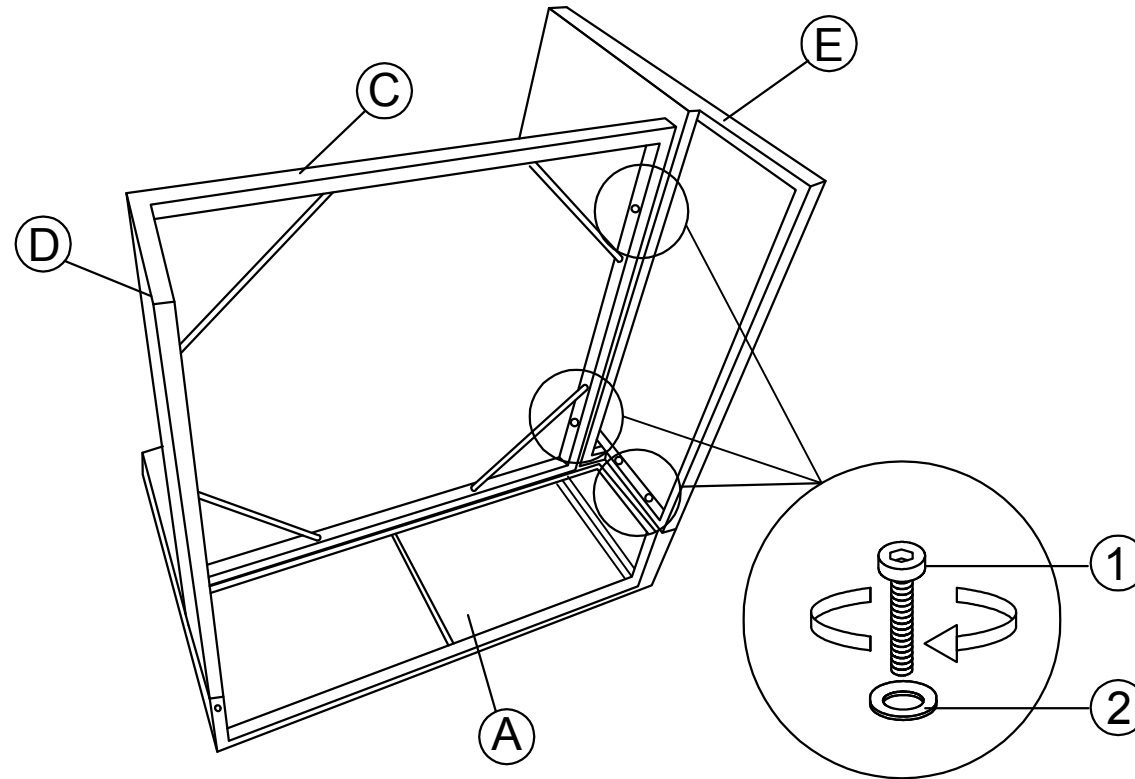
STEP4



① Bolt	② Washer
	
M6x45 x4	x4



Right

Please DO NOT tighten the screws at this step yet. Wait to tighten all the screws until the product is fully installed.

Assembly Instruction

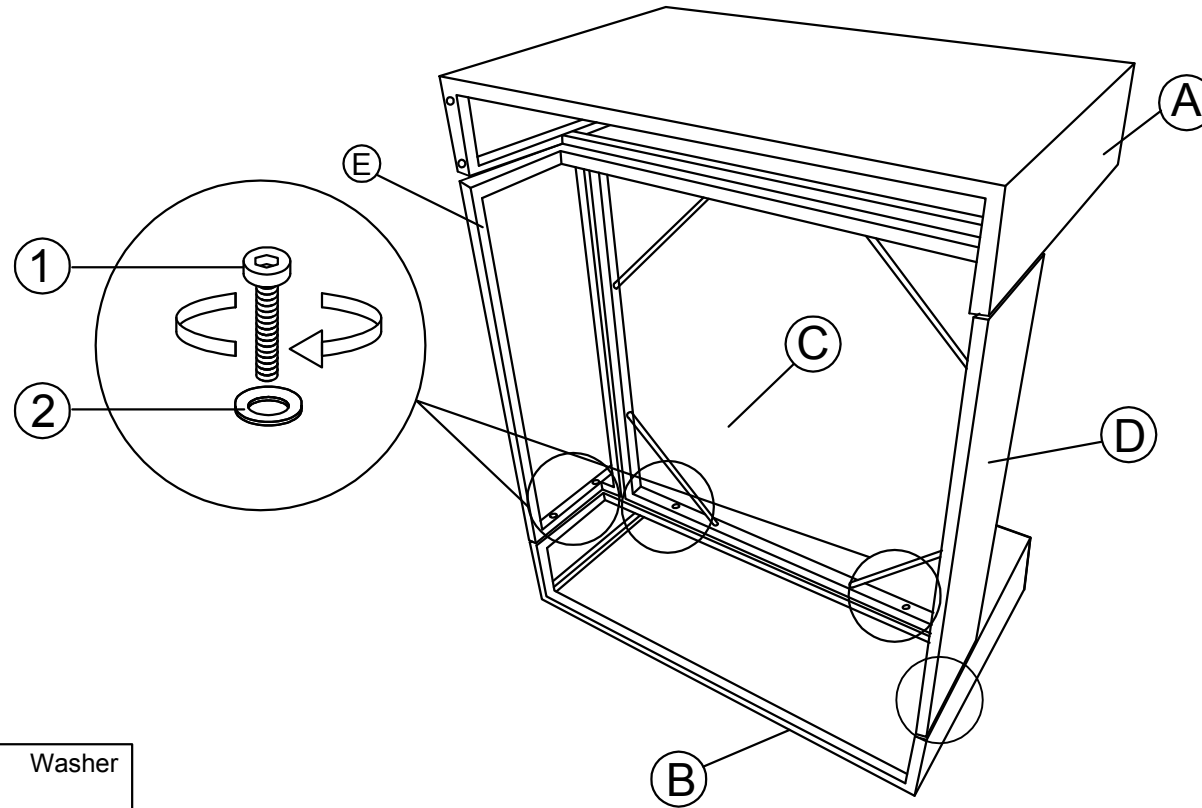
STEP5



Ⓑ Left Armrests	① Bolt	② Washer
 x1	 M6x45 x6	 x6

Please tighten the screws at this step yet.



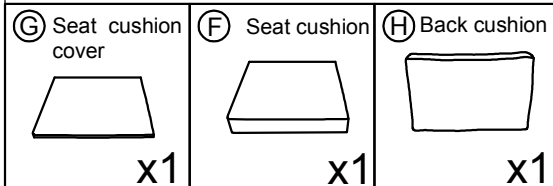
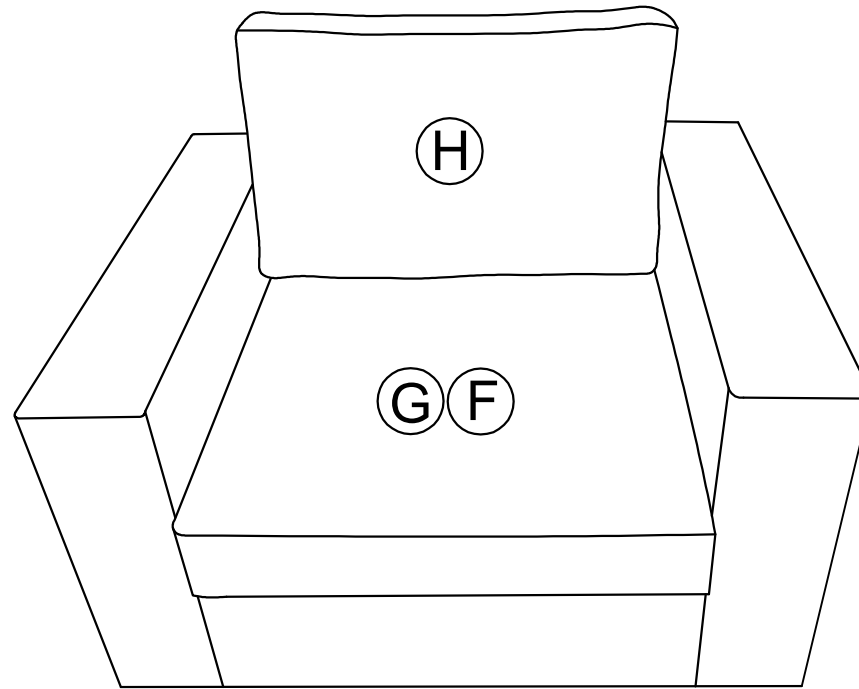

Assembly Instruction

STEP6

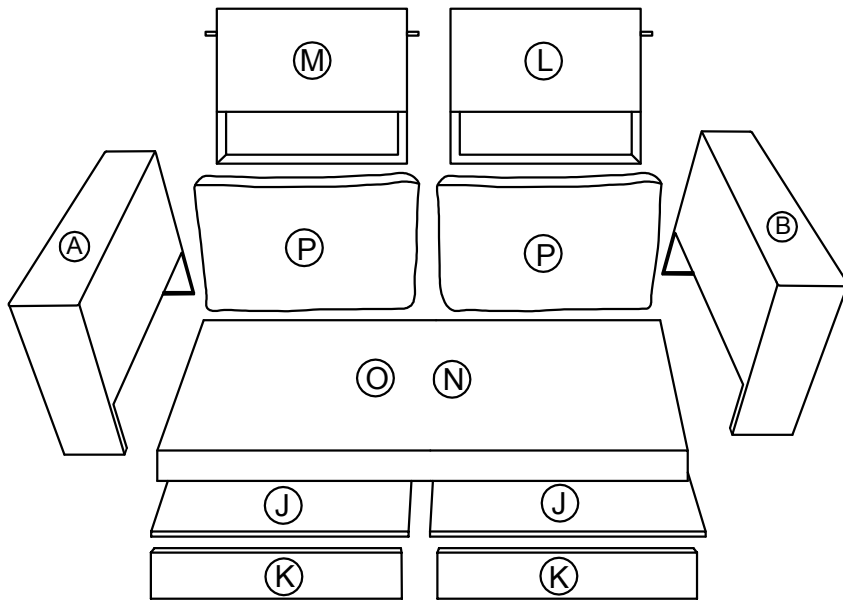



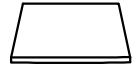
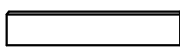
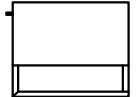
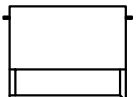
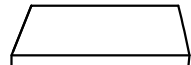
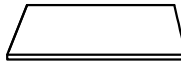

SOFA

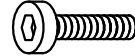
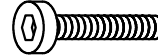

<p>(A) Right Armrests x1</p> 	<p>(B) Left Armrests x1</p> 	<p>(J) Seat x2</p> 	<p>(K) Side panel x2</p> 	<p>(L) Back rest x1</p> 
<p>(M) Back rest x1</p> 	<p>(N) 2-seat cushion x1</p> 	<p>(O) 2-seat cushion cover x1</p> 	<p>(P) Back cushion x2</p> 	

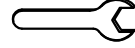

Hardware parts

<p>(1) Bolt M6x45 x20</p> 	<p>(4) Bolt M6x70 x6</p> 	<p>(2) Washer x32</p> 	<p>(5) Nut x6</p> 	<p>(3) Allen Key x1</p> 
<p>(6) Spanner x1</p> 				

Assembly Instruction

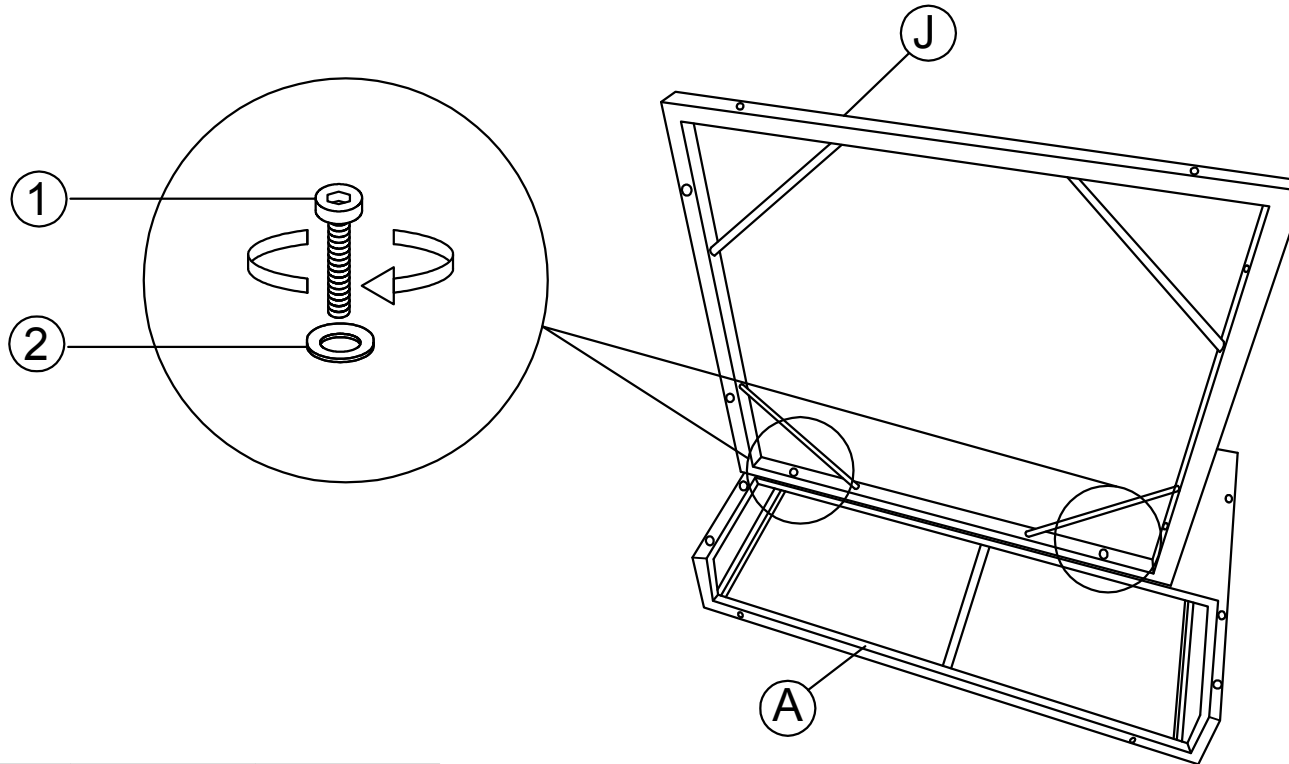
STEP 1

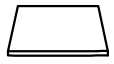

(A) Right Armrests	(J) Seat	(1) Bolt	(2) Washer
			
x1	x1	M6x45 x2	x2

Right



Place the Armrests on the ground before assemble.
Please DO NOT tighten the screws at this step yet. Wait to tighten all the screws until the product is fully installed.

Assembly Instruction

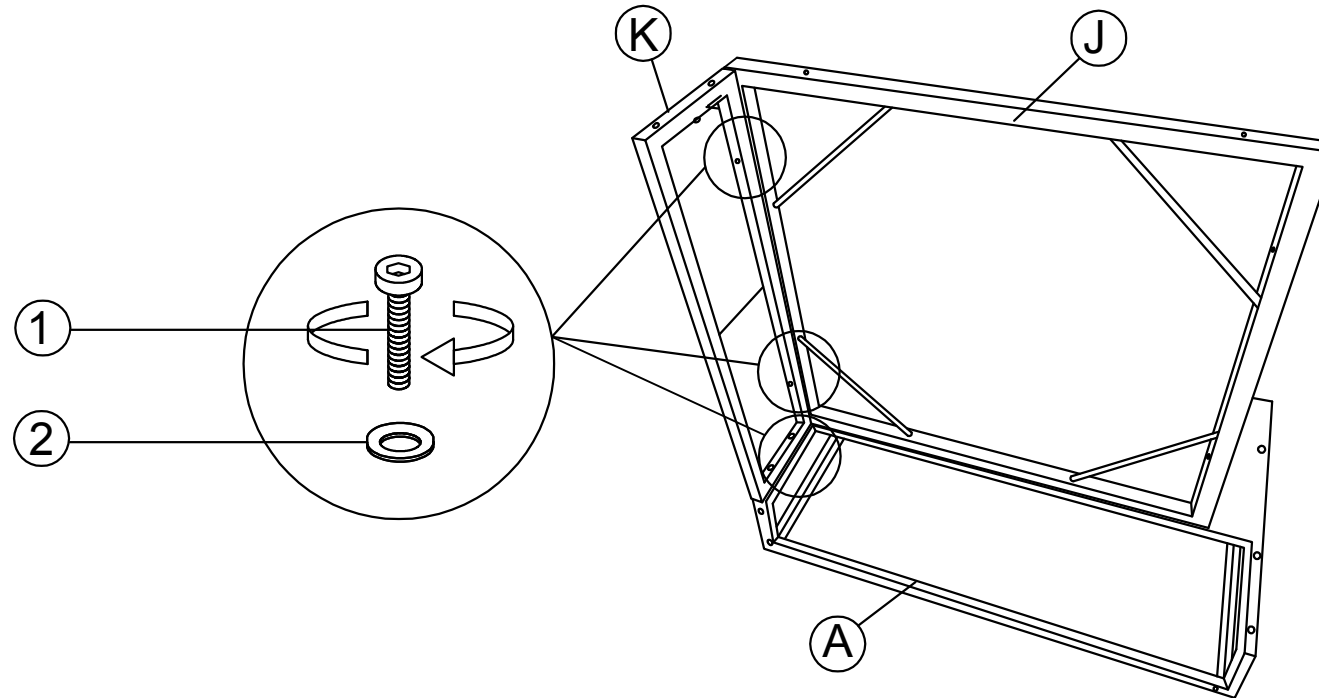
STEP2



Right

(K) Side panel  x1	(1) Bolt  M6x45 x4	(2) Washer  x4
---	--	---

Please DO NOT tighten the screws at this step yet. Wait to tighten all the screws until the product is fully installed.

Assembly Instruction

STEP3

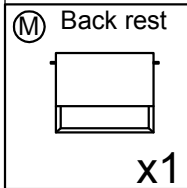
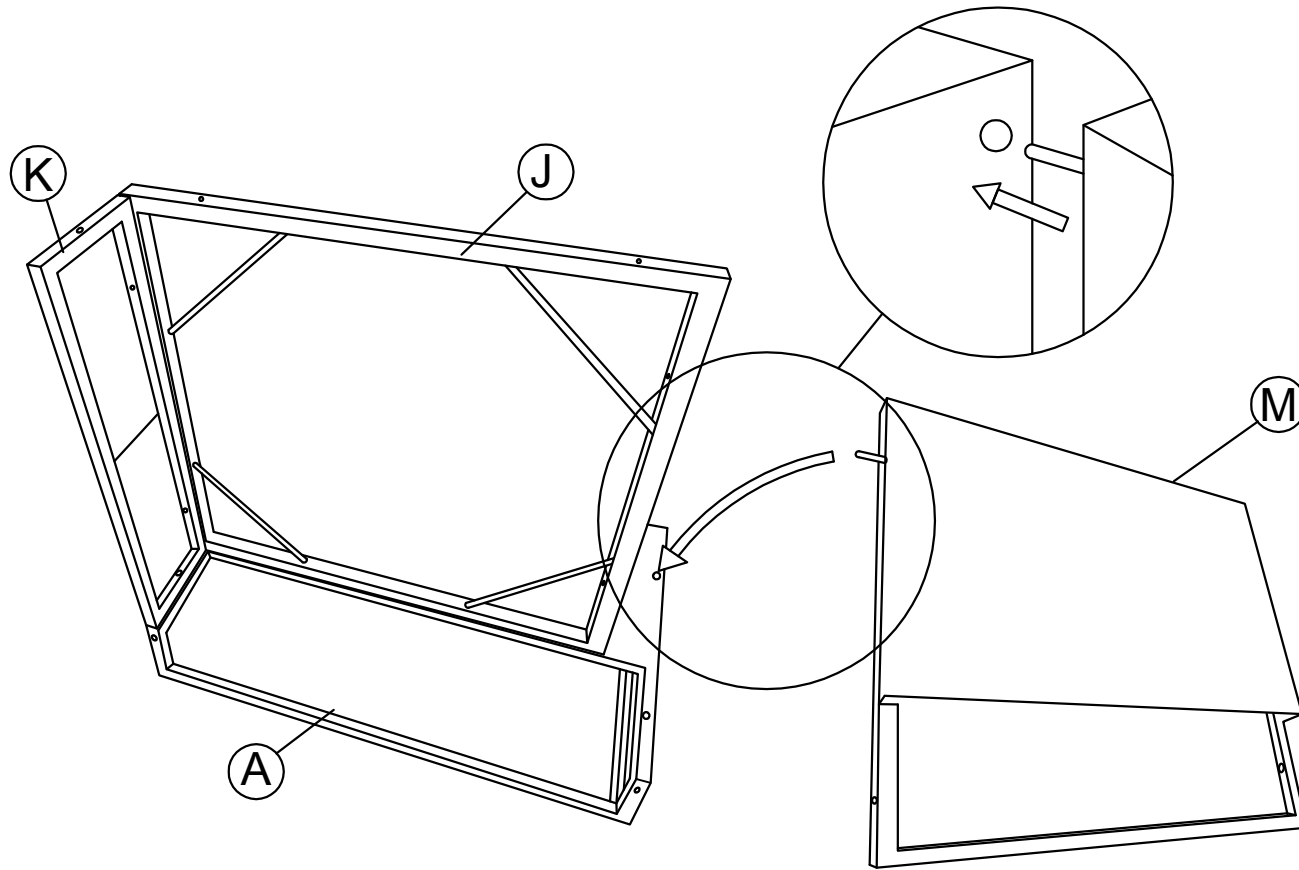

Right

Please DO NOT tighten the screws at this step yet. Wait to tighten all the screws until the product is fully installed.

Assembly Instruction

STEP4

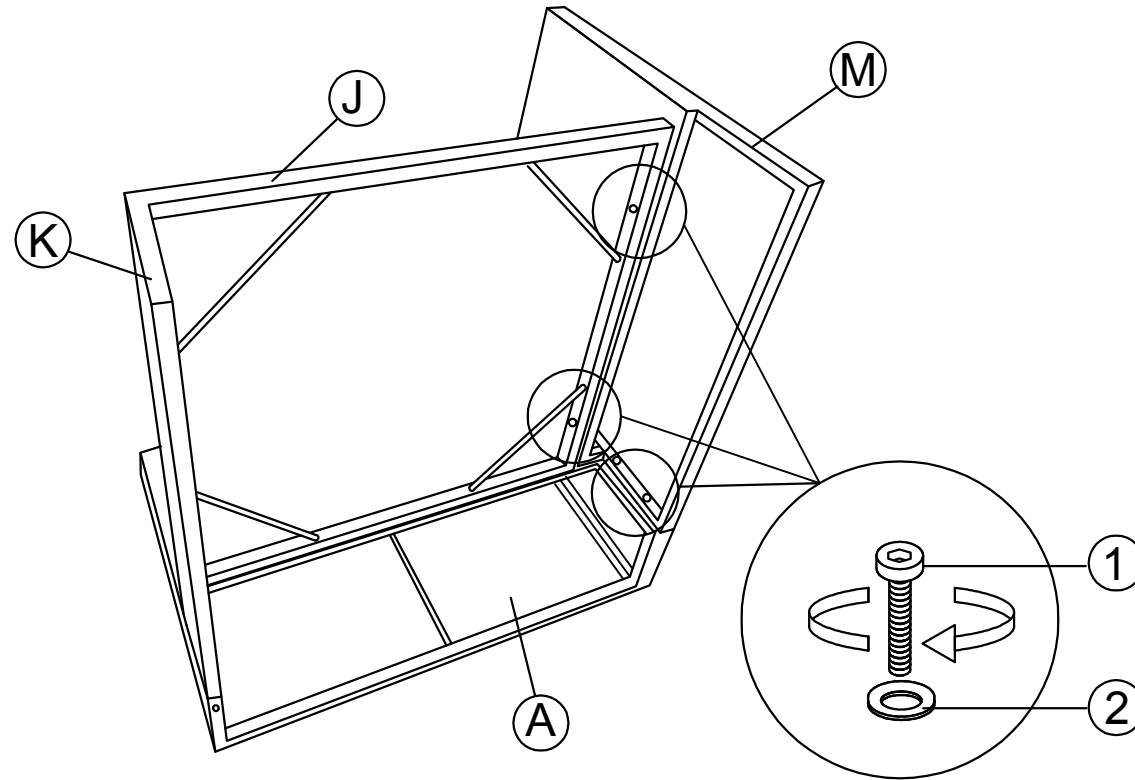

Right

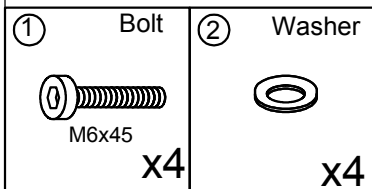



Please DO NOT tighten the screws at this step yet. Wait to tighten all the screws until the product is fully installed.

Assembly Instruction

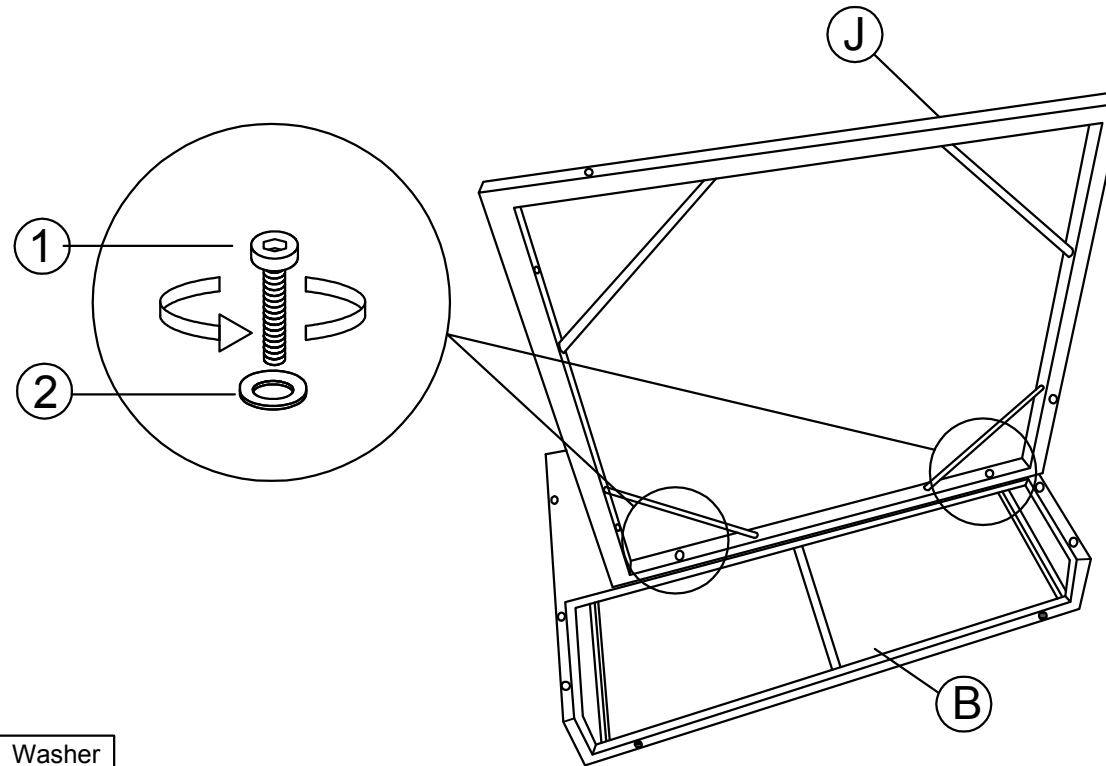
STEP5

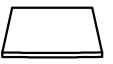

Left



ⓐ	Seat	①	Bolt	②	Washer
					
	x1	M6x45 x2		x2	

Please DO NOT tighten the screws at this step yet. Wait to tighten all the screws until the product is fully installed.

Assembly Instruction

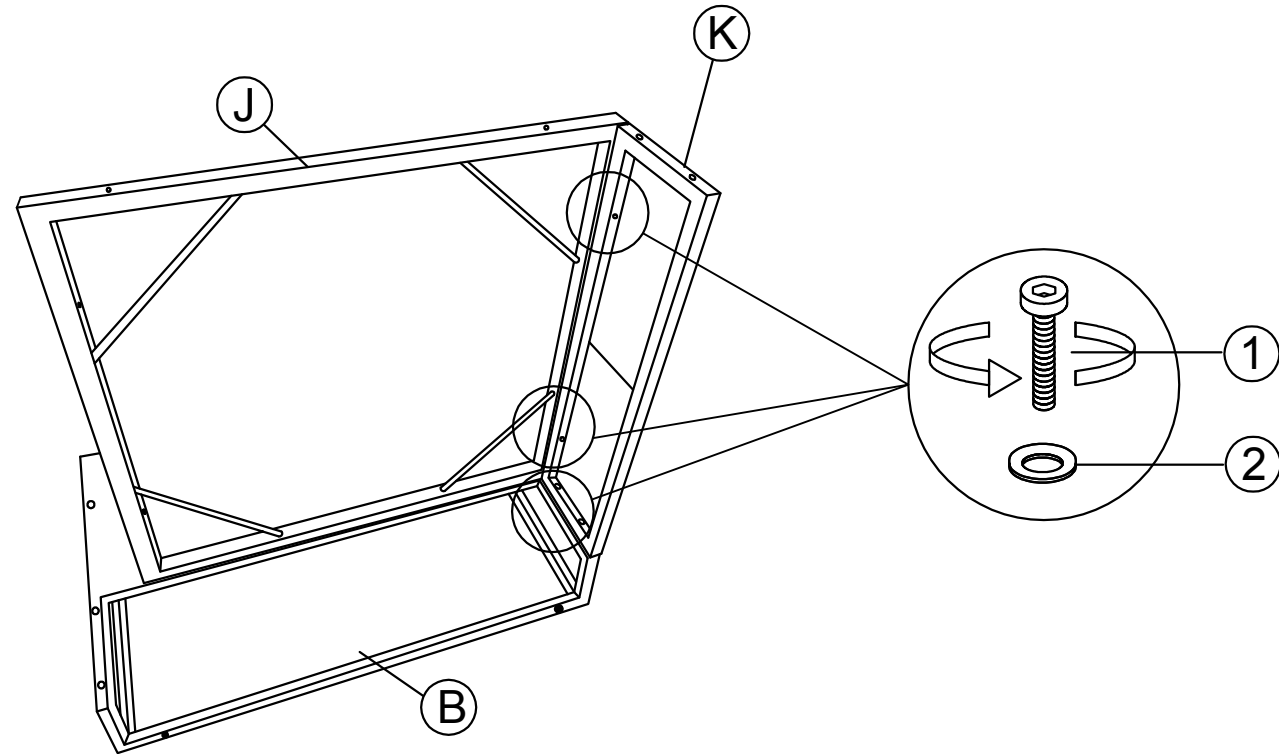
STEP 6

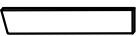

(K) Side panel  x1	(1) Bolt  M6x45 x4	(2) Washer  x4
---	--	---

Left

Please DO NOT tighten the screws at this step yet. Wait to tighten all the screws until the product is fully installed.

Assembly Instruction

STEP 7

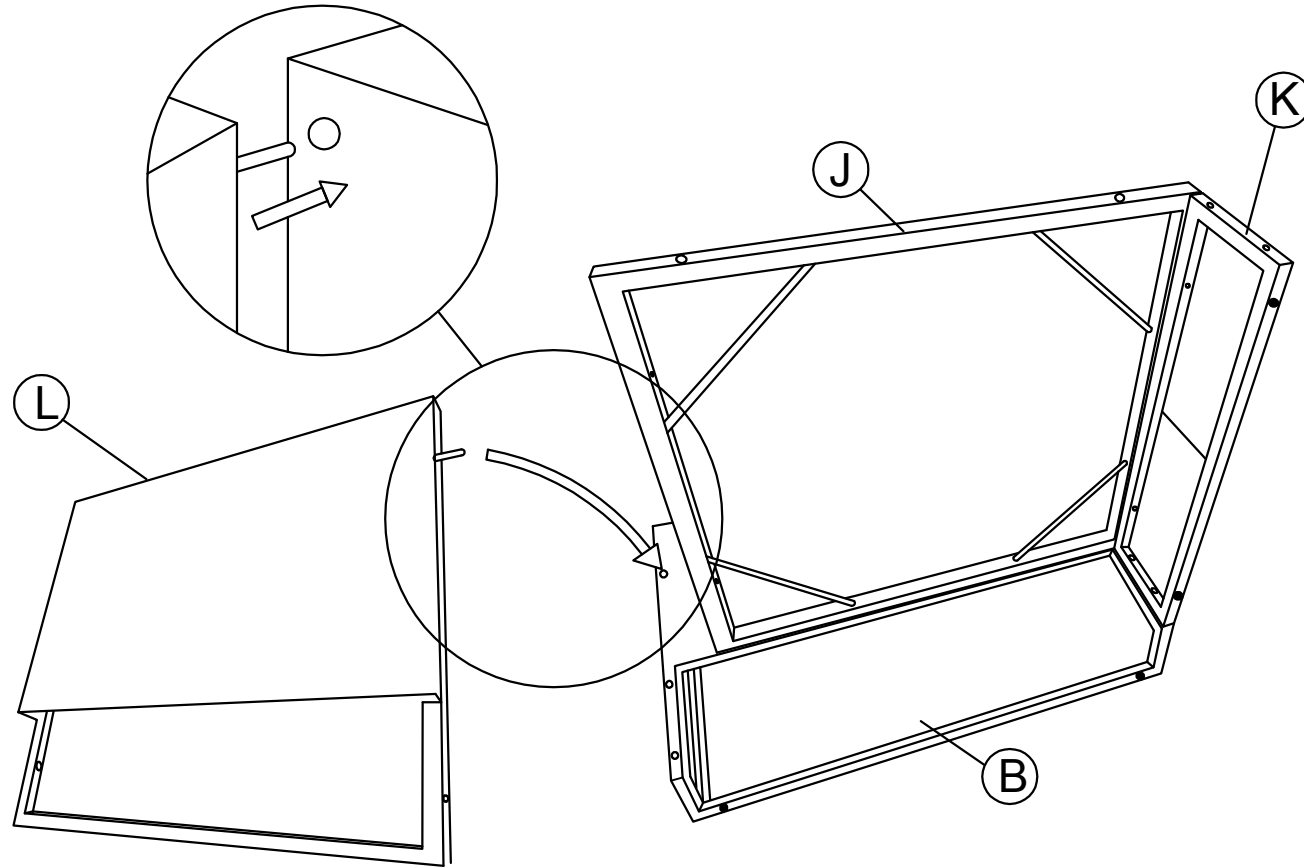

Left

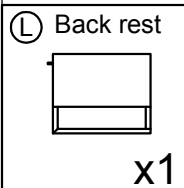



Please DO NOT tighten the screws at this step yet. Wait to tighten all the screws until the product is fully installed.

Assembly Instruction

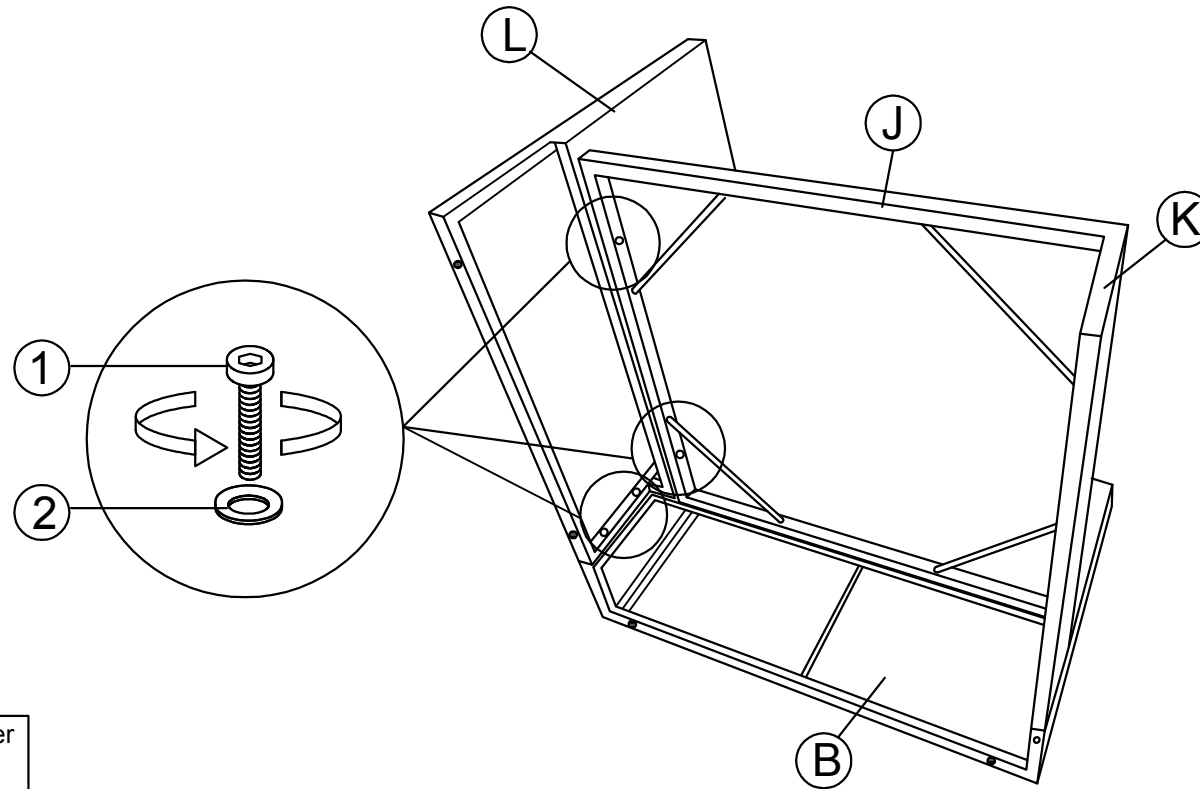
STEP 8



Left

① Bolt	② Washer
	
M6x45 x4	x4

Please DO NOT tighten the screws at this step yet. Wait to tighten all the screws until the product is fully installed.

Assembly Instruction

STEP9

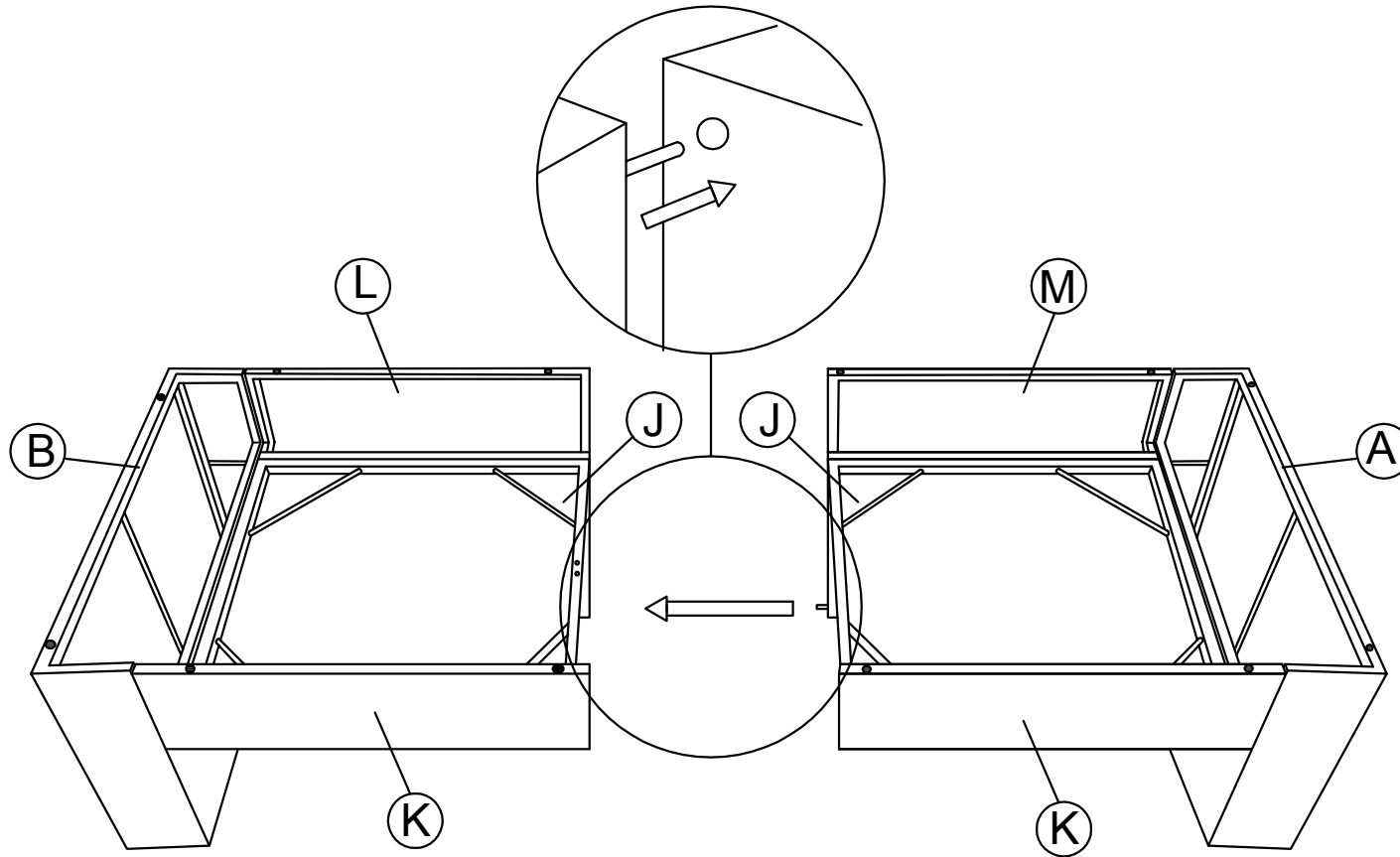

Please DO NOT tighten the screws at this step yet. Wait to tighten all the screws until the product is fully installed.

Assembly Instruction

STEP10

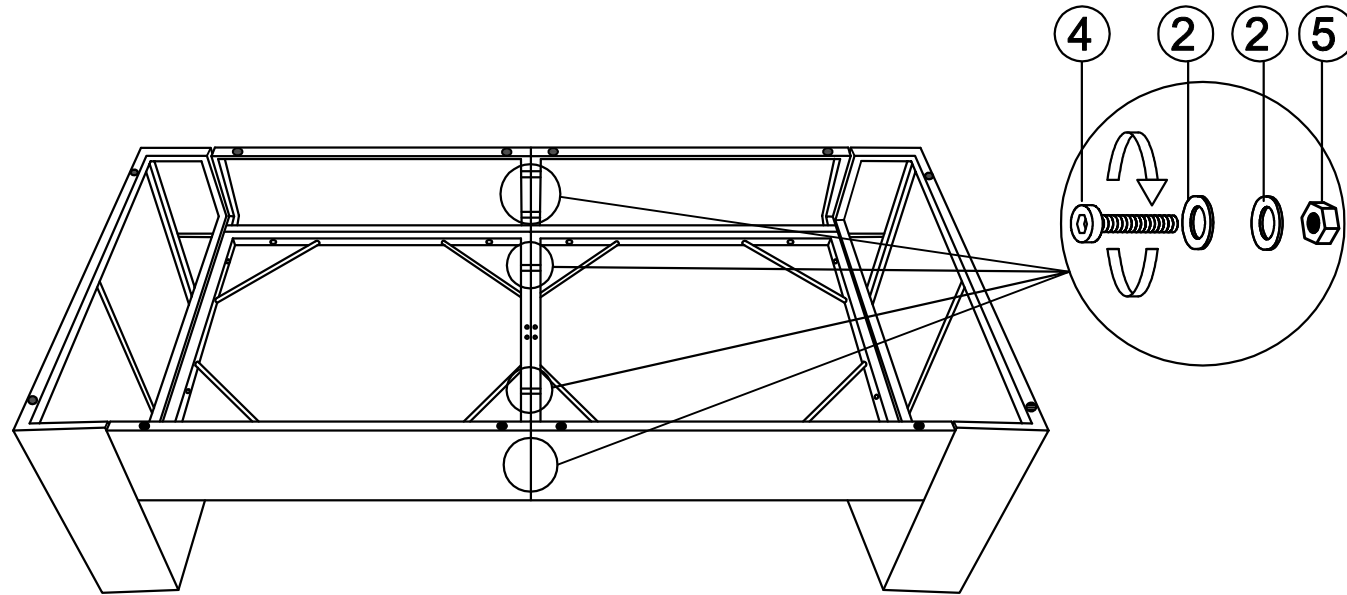

④ Bolt M6x70 x6	② Washer x12	⑤ Nut x6
-----------------------	-----------------	-------------

Please tighten the screws at this step yet.

Assembly Instruction

STEP11

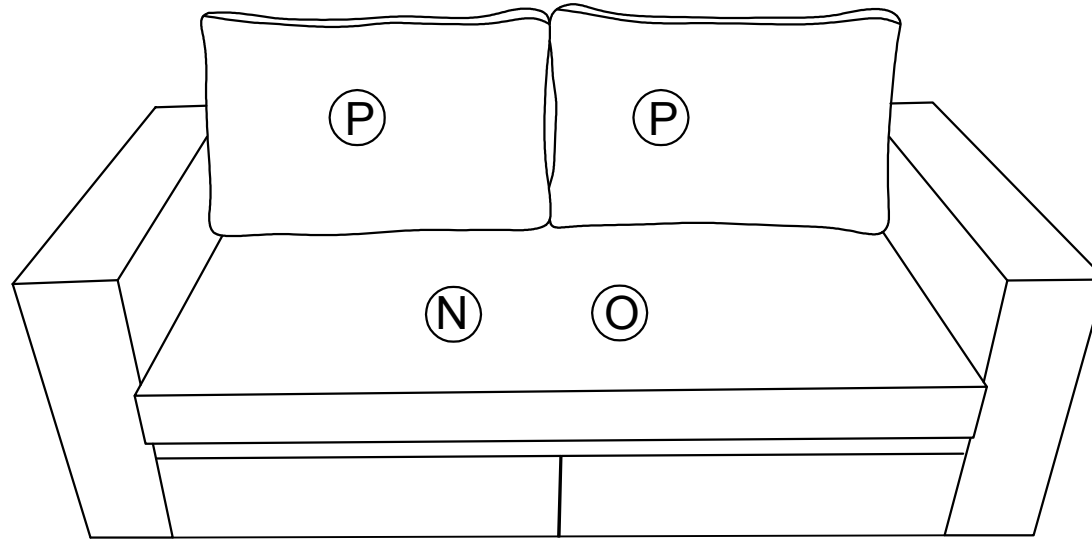

Ⓝ 2-seat cushion

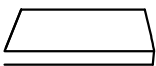

x1

Ⓞ 2-seat cushion cover

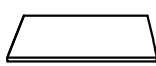

x1

Ⓟ Back cushion



x2

TABLE

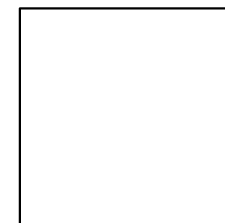
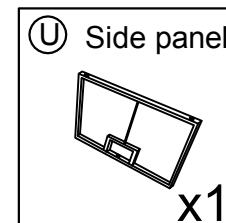
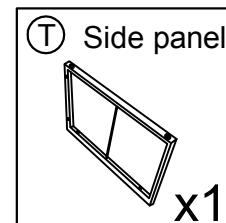
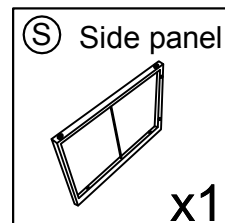
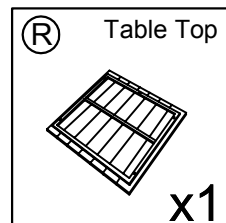
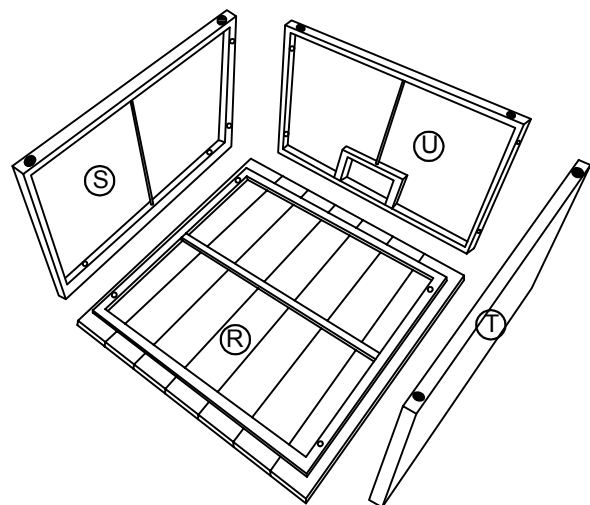

Hardware parts

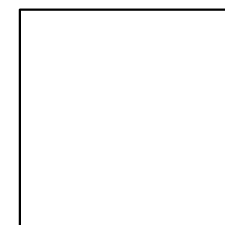
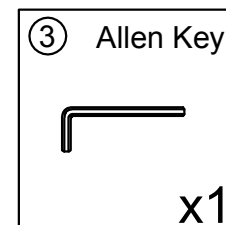
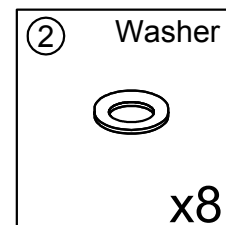
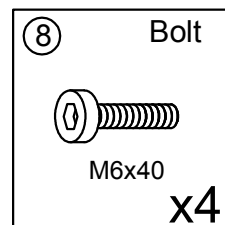
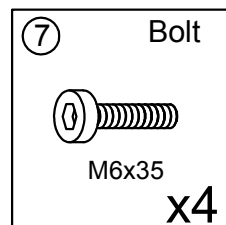

STEP1

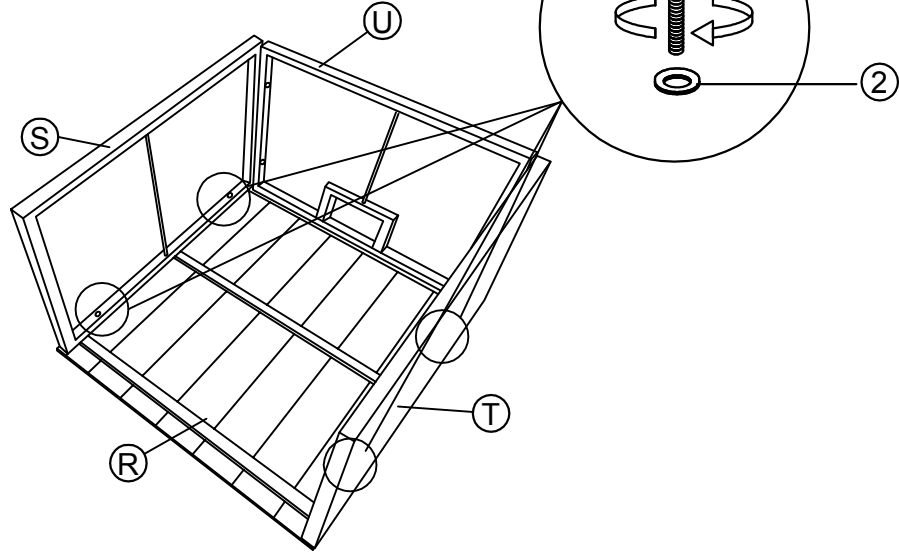

STEP2

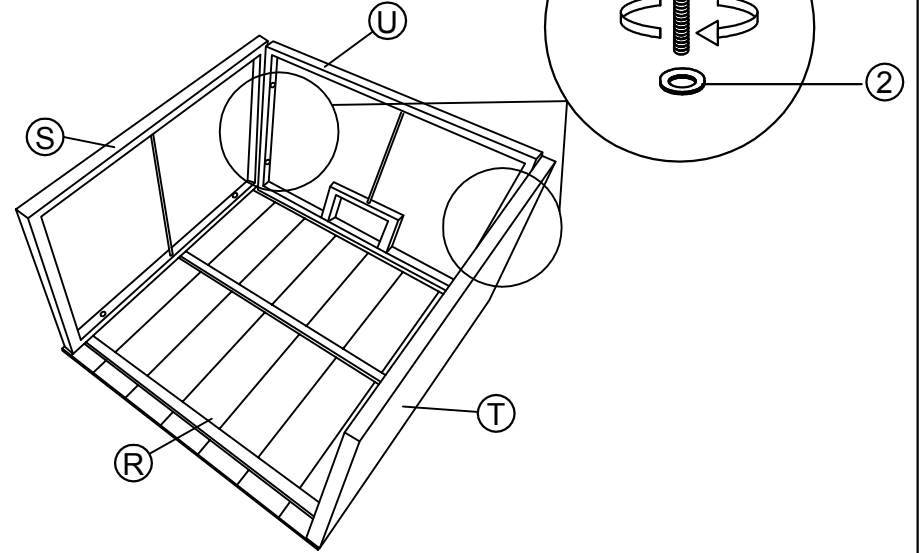

STEP3

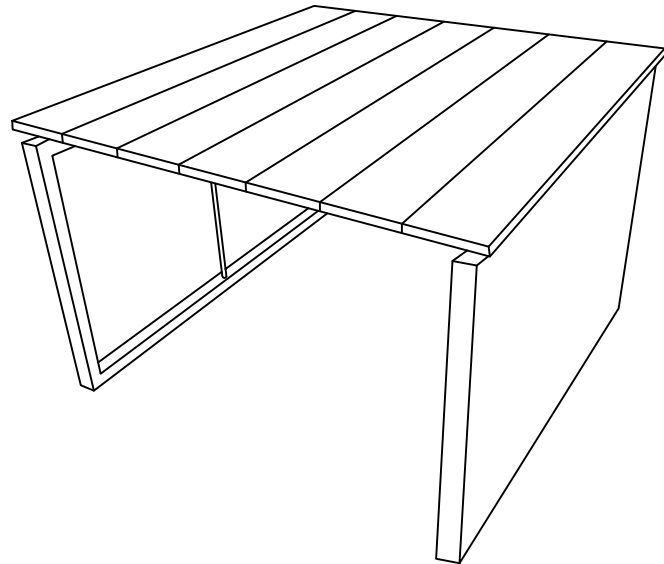

TABLE

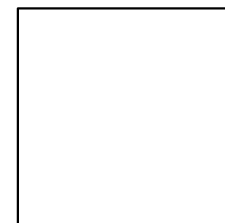
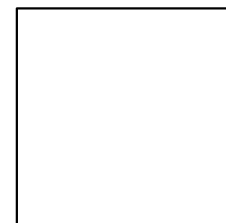
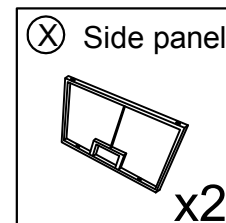
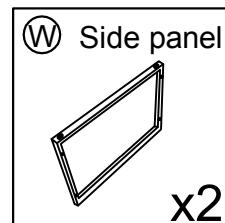
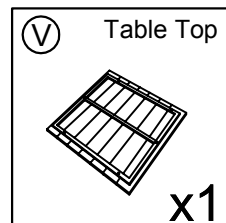
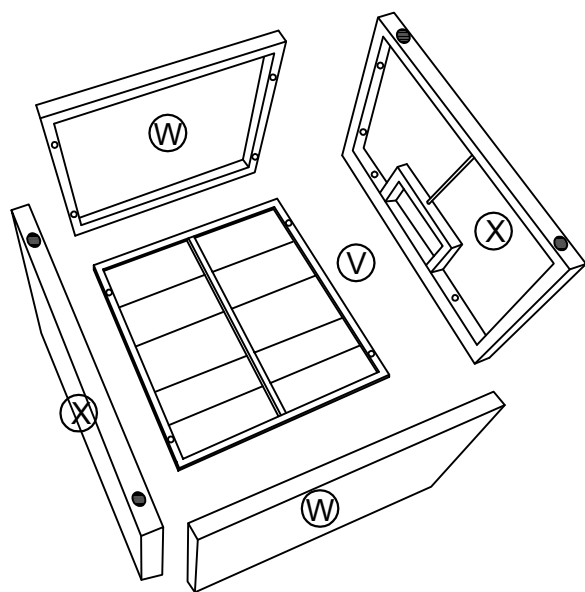

Hardware parts

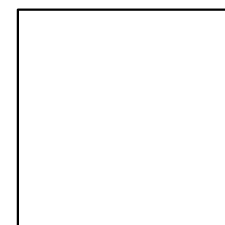
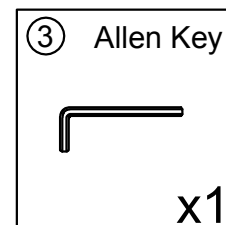
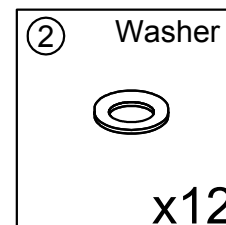
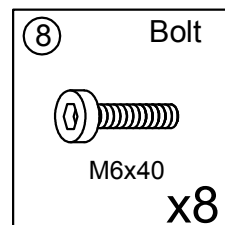
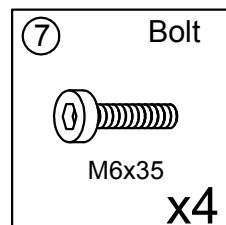

STEP1

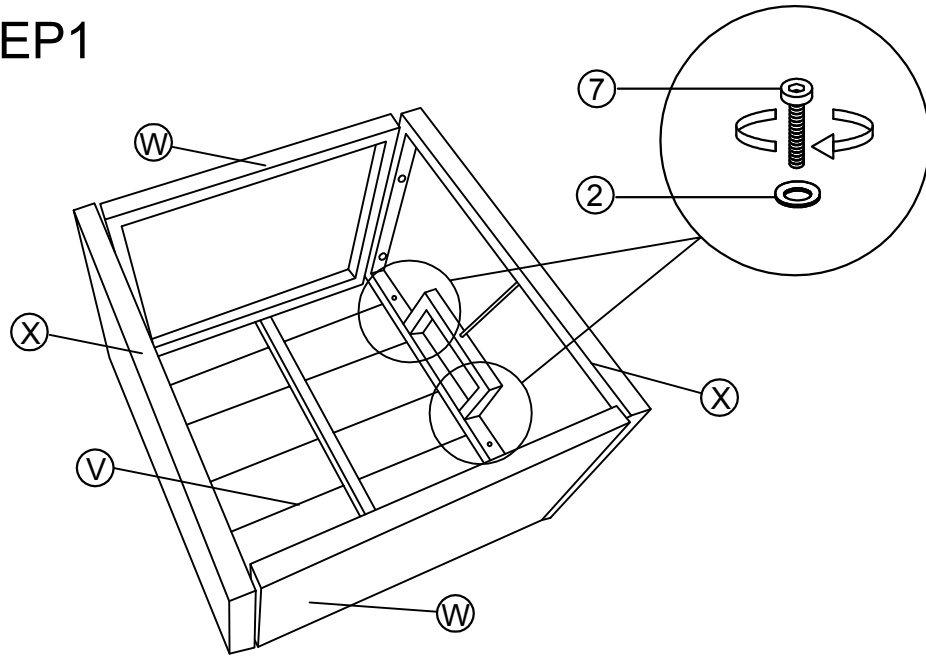

STEP2

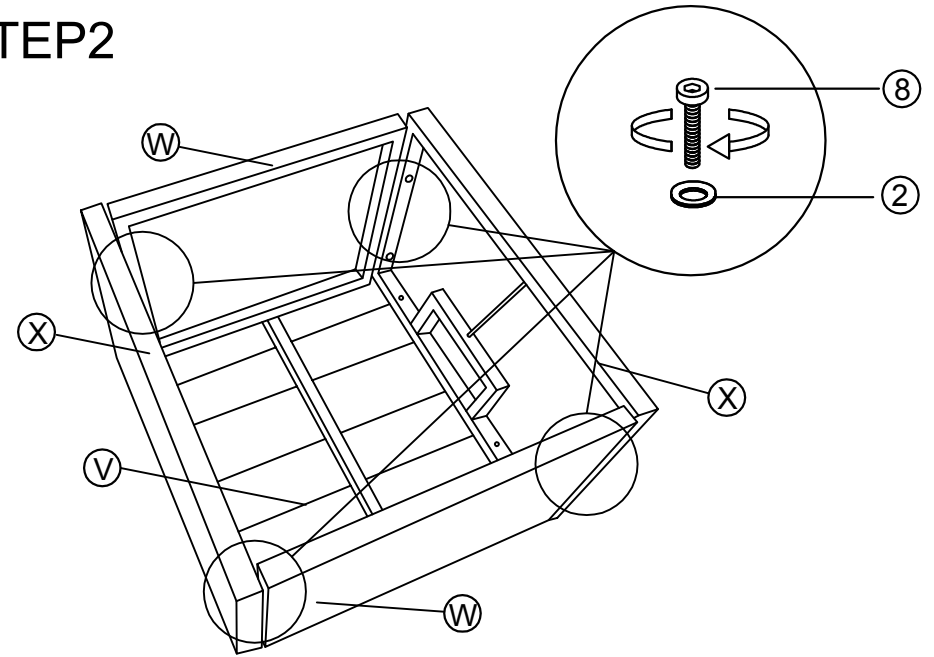

STEP3

