

Assembly Instructions

MODEL:AM959

PRODUCT SIZE(LxWxH): 10X18

PLEASE READ CAREFULLY BEFORE ASSEMBLY

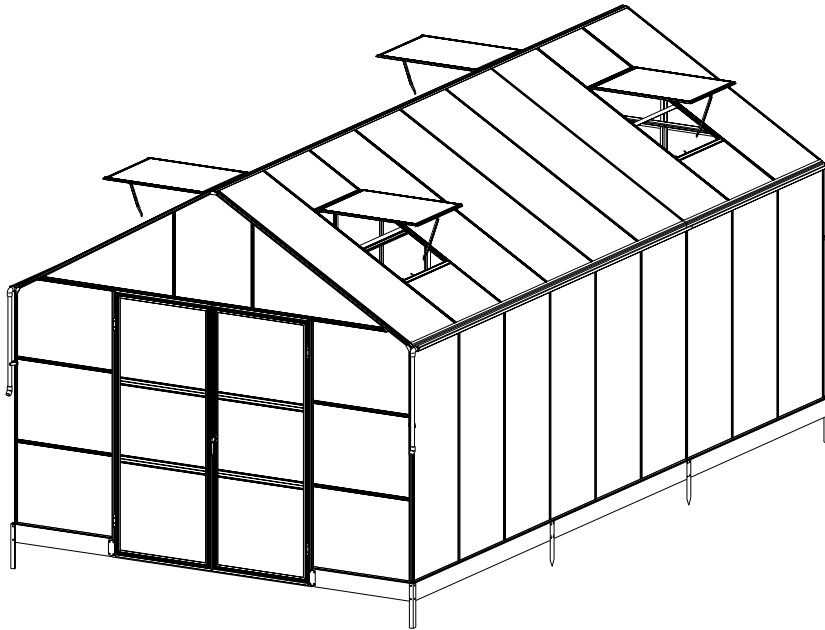

Greenhouse 10x18 FT Assembly Instruction

SKU:

YPG010-1B3A1(BOX 1)

YPG010-1B3A2(BOX 2)

YPG010-1B3A3(BOX 3)

Arrive in 3 separate boxes and may not be part of the same shipment; Please install the product after receiving all the packages.

Email Address:support@wepatio.com

Tel: 901-347-2181

Service Time: 8 am - 5 pm (central time) Monday-Friday.

If no one picks up, please call several more times

2024/10/14

CONTENTS

1. Assembly Advice	Page 1
2. Product Features	Page 2
3. Parts List	Page 3 -6
4. Door Assembly	Page 7 - 12
5. Roof Vent Assembly	Page 13 - 15
6. Base Assembly	Page 16-18
7. Framework & Glazing Assembly	Page 19 - 40

Assembly and Maintenance Advice

1. For safety purposes, we strongly recommend that this product is assembled by at least two people.
2. Some components have sharp metal edges. Please be careful when handling metal components. Please wear gloves, shoes and safety goggles during assembly.
3. Lay all of the components on a soft carpet or blanket to avoid any scratches or damages.
4. DO NOT climb or stand on the roof. Heavy articles should not be leaned against the greenhouse.
5. Keep the roof and gutter clear of snow, dirt & leaves. Allowing snow to build up on the roof may damage the product.
6. Unlike steel, if the paint finish is scratched this will not harm the aluminium underneath.
7. When your product needs cleaning, use a mild detergent solution and rinse with cold clean water. Do not use acetone, abrasive cleaners or strong detergents to clean the panels.

Tools Provided:

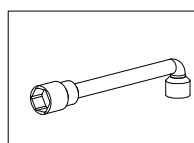
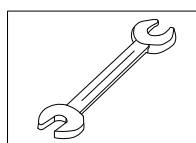
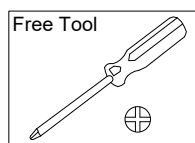

Tools Required when Assembly (Not Provided)

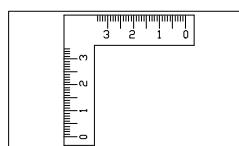
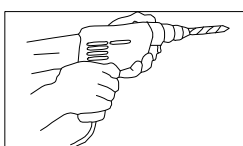
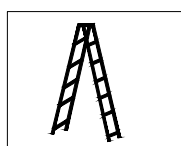
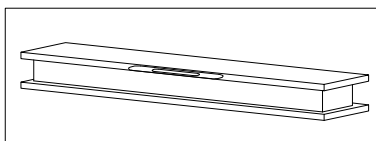
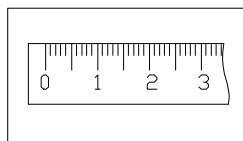
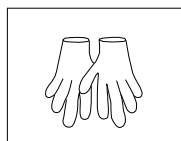

Assembly at least by two Persons



Important:

Rubber is not provided if you choose polycarbonate sheet as glazing panel.

Functions and Features:

1. The strong two part eaves beam includes an integral gutter. Downpipes are also included as standard so you can collect rainwater.

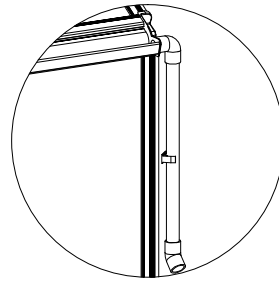

2. Manual window handles are included as standard with the roof vents.

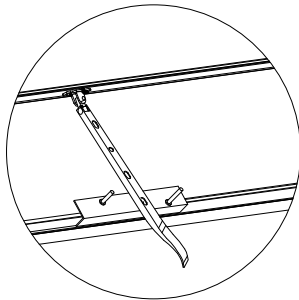





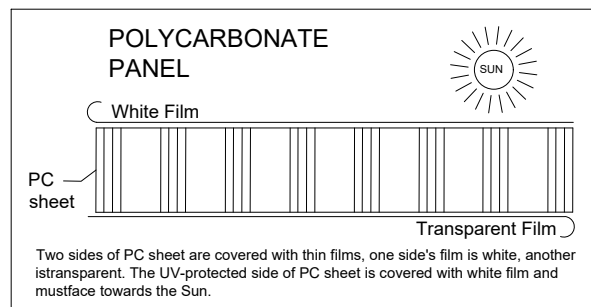

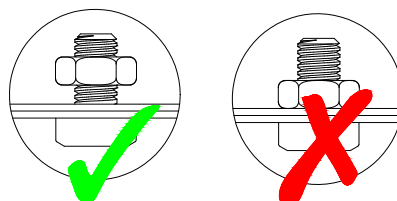

Manual Opener

3. Remove approximately 2 inches of film from all sheet edges before installing and remove all film immediately after the construction is completed. Please ensure that the side with the white film faces outwards.



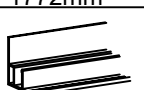

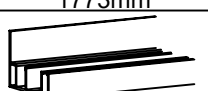
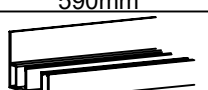
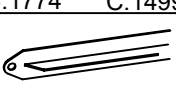





4. This quality greenhouse features self-tapping screws to provide strong joints. As the name suggests, the screws tap their own thread. Driving in self-tapping screws requires more force than conventional screws. A powered screwdriver is therefore recommended.
5. Nuts not to be tightened before the end of assembly! Unless otherwise stated, do not tighten the bolts/nuts/screws until the shed is finally erected!



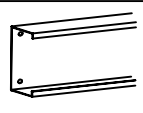

	PART	NO	QTY
1	 717mm	L02F	4
2	 1772mm	L06C	3
3	 1772mm	L07C	6
4	 1772mm	L08C	6
5	 726mm	L08E	1
		L08F	1
6	 1773mm	L09C	6
7	 590mm	L10A	2
8	 B:1774 C:1499	L10B	1
		L10C	1
9	 1753mm	L23C	12
		L23D	1
10	 1776mm	L26A	1
		L26B	1

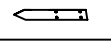
door





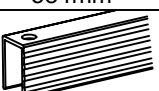
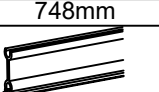

	PART	NO	QTY
11	 1760mm	L16A	2
12	 642mm	L17	4
13	 723mm	L18A	2
		L18B	2
14	 1792mm	L18C	1
15		L18D	1

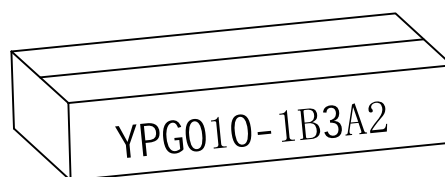

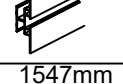
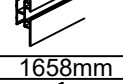
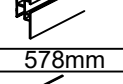

PART	NO	QTY
	A2	2
	C2	4
	C3	2
A2:755 C2:1802 C3:1773 D2:1506	D2	2
	D306	4
	D307	5
	D317	2

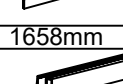
windowsX4

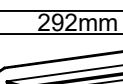
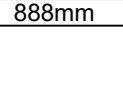

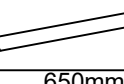





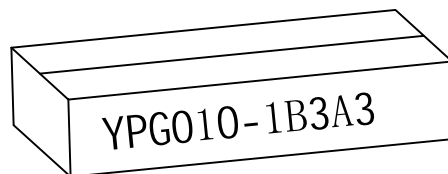





	PART	NO.	QTY.
16	 584mm	L11A	4
17	 748mm	L19	8
18	 584mm	L20	4
		 584mm	L21





























	PART	NO	QTY
1		L01A	1
	1547mm	L01B	1
2		L01C	2
	1658mm	L01D	2
3		L01E	1
	1547mm	L01F	1
4		L02A	6
	1547mm		6
5		L02B	6
	1658mm		6
6		L02C	2
	578mm	L02D	2
7		L02E	5
	570mm		
8		L03A	4
	1547mm		
9		L03B	4
	1658mm		
10		L04A	4
	570mm		
11		L05B	6
	292mm		
12		L23A	4
	888mm		

	PART	NO	QTY
13		L23E	6
	600mm		
14		L25	4
	650mm		
15		L26C	1
	C:1656 D:1334	L26D	1
16		L26C	1
	C:1656 E:1334	L26E	1
17		L26C	1
	C:1656 E:1334	L26F	1
18		L26C	1
	C:1656 G:1334	L26G	1





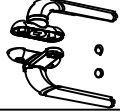





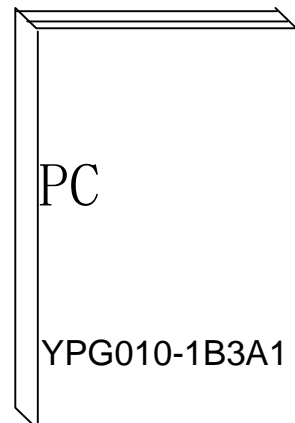
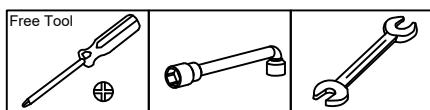







PART	NO	QTY
	Y1	2
582X1013mm		
	Y2	2
582X1013mm		
	Y3	2
754X588mm		
	Y4	1
556X735mm		
	Y5	1
556X735mm		
	Y6	18
1568X588mm		
	Y7	14
1682X588mm		
	Y8	4
556X735mm		
	Y9	8
448X588mm		
	Y10	4
726X582mm		
	Y11	6
550X662mm		
	Y14	1
556X588mm		
	Y15	1
556X588mm		
	Y17	5
1115X588mm		
	Y18	3
556X588mm		

PART	NO	QTY
	J55	2
	J56R	2
	J56L	2
	J94	4
	J93	4
	J165	4
	J166	4
	A01	4
	A03	4
	A51	4
	D17	8
	D25	4
	D26	2
	D45	8
	D38	4
	D309	4
	A114	2
	S01 M6X12	420+5
	M01 M6	420+5
	Z02 Ø4X16D	32
	Z04 Ø4X8	8
	Z08 M4.2X16	98
	Z17 M4.8X16	8
	D114	20
	S69 M6X60	20

PART	NO	QTY
	H152	1
	S76 M4X32	2
	D47	1

Tools Provided:



PART	NO	QTY
	Y1	2
	Y2	2
	Y3	2
	Y4	1
	Y5	1
	Y6	18
	Y7	14
	Y8	4
	Y9	8
	Y10	4
	Y11	6
	Y14	1
	Y15	1
	Y17	5
	Y18	3

Panel Exploded View

Back Wall

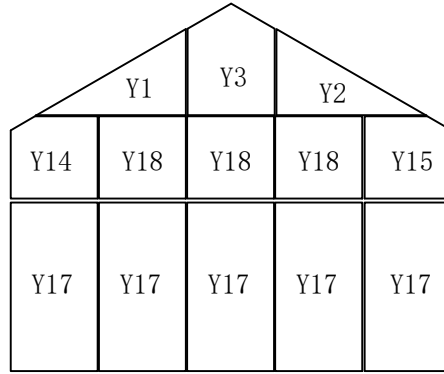



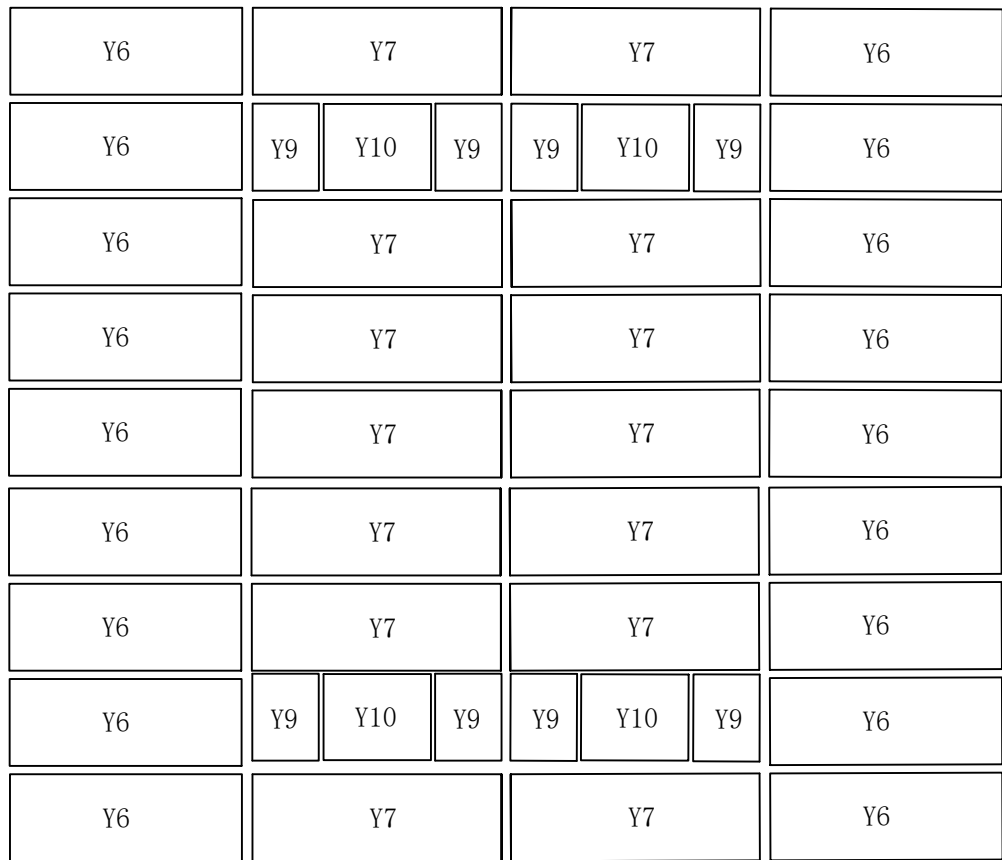



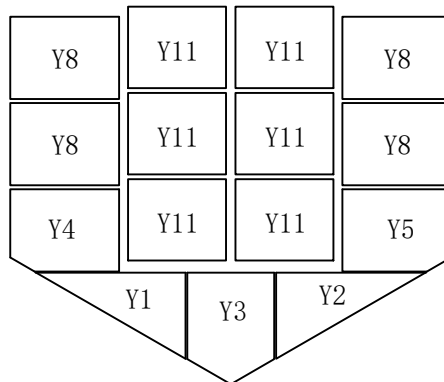



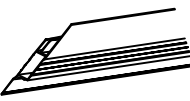

Side
Wall

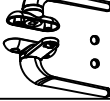

Side
Wall



Front Wall





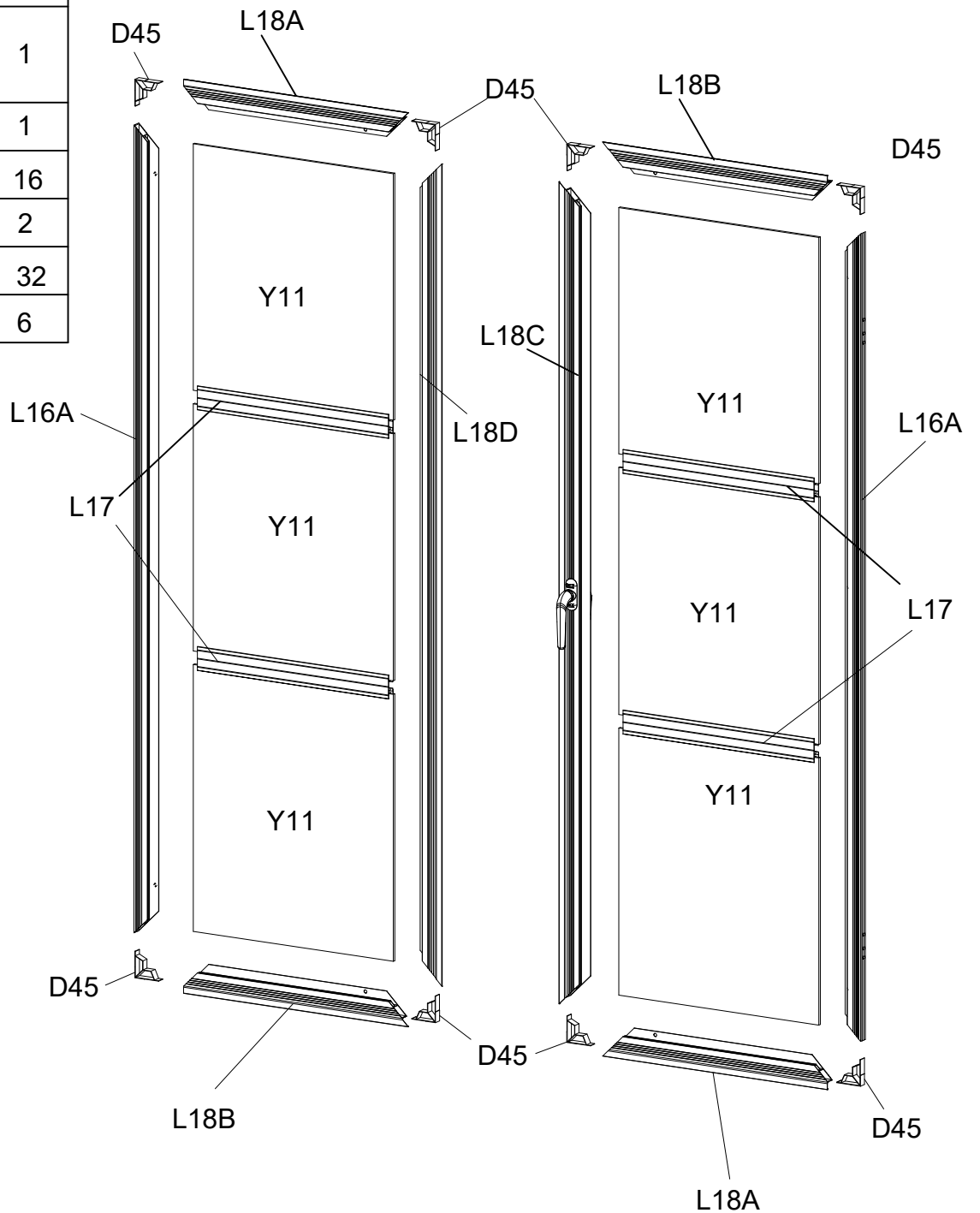

PART	NO	QTY
	L16A	2
	L17	4
	L18A	2
	L18B	2
	L18C	1
	L18D	1
	D45	8
	H152	1
	D47	1
	S26	16
	M5X12	
	S76	2
	M4X32	
	Z08	32
	M4.2X16	
	Y11	6

Exploded View

Left Door

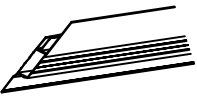
Right Door



PART	NO	QTY
	L16A	1
	L17	2
	L18A	1
	L18B	1
	L18D	1
	D45	4
	S26	8
	M5X12	
	Z08	16
	M4.2X16	
	Y11	3

Left Door

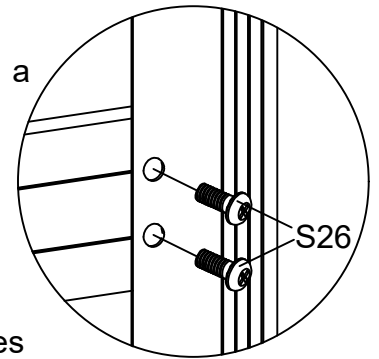
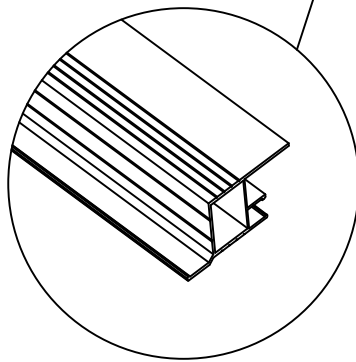
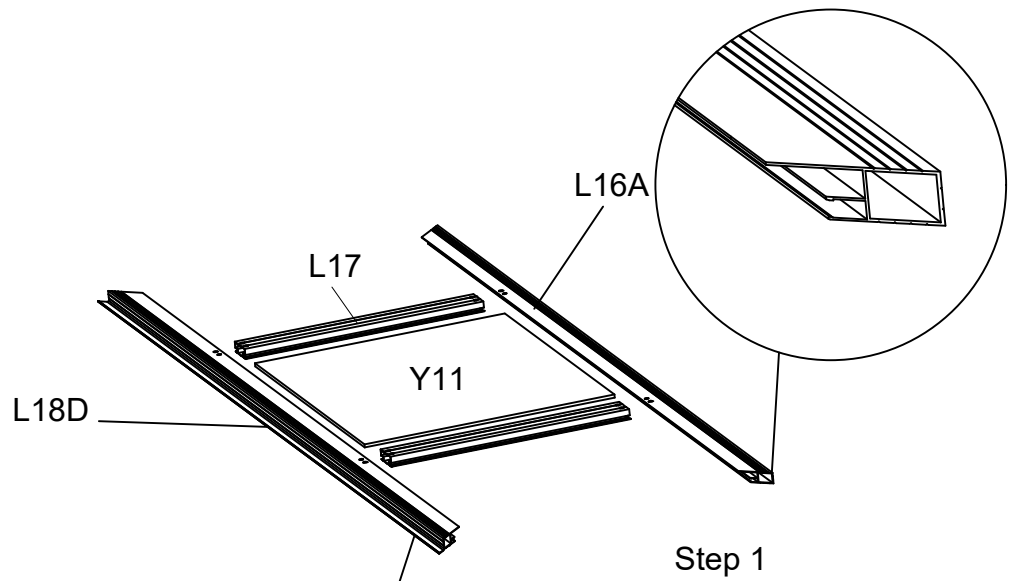

! Attention: Check the direction of the accessories

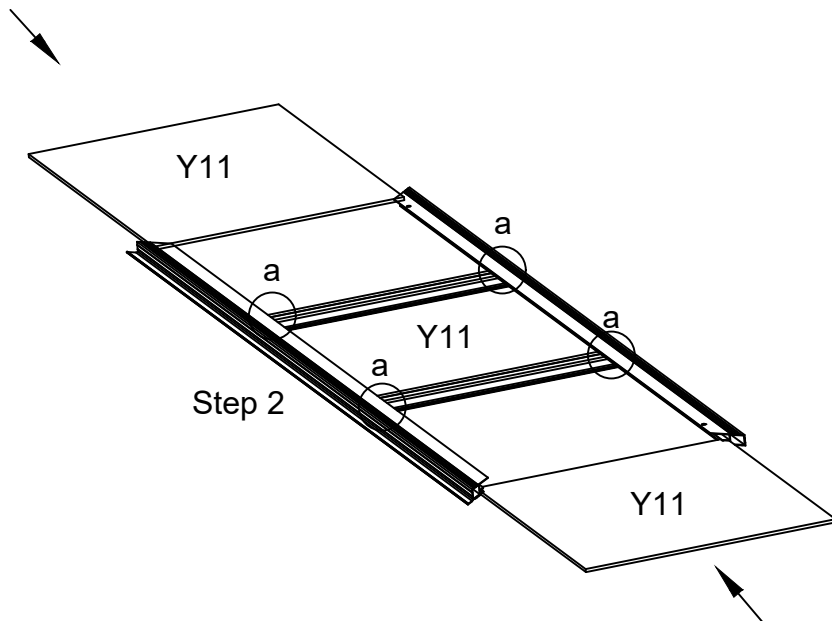

! Attention: Remove the protective films from both sides of each polycarbonate panel, before inserting into aluminum channels. Ensure the milky white film faces towards the Sun.

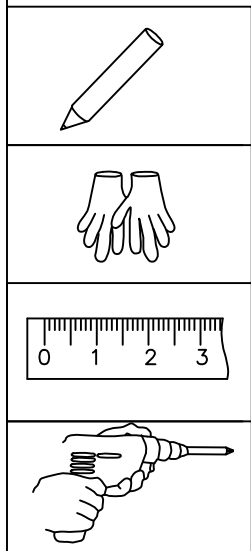

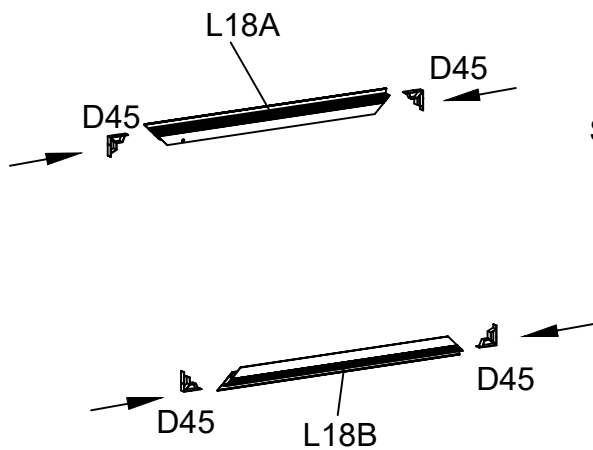

Step 3

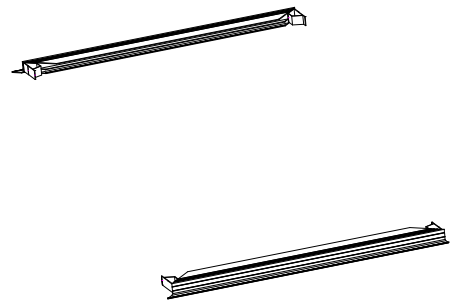



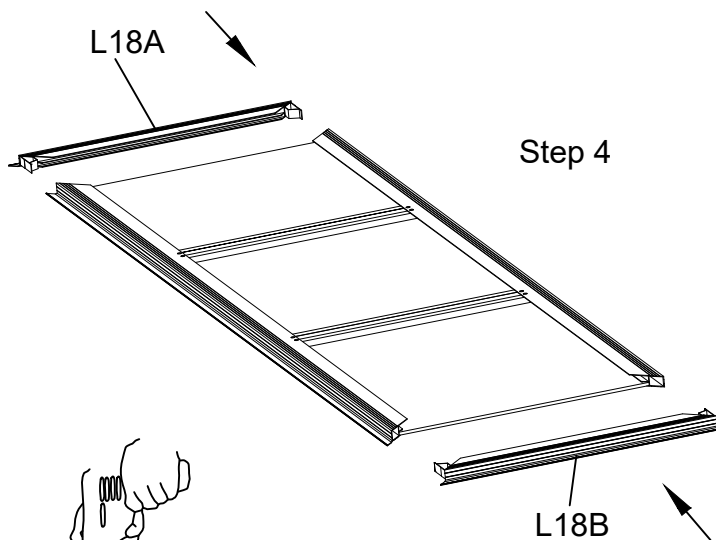



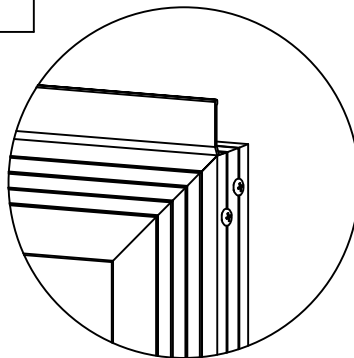
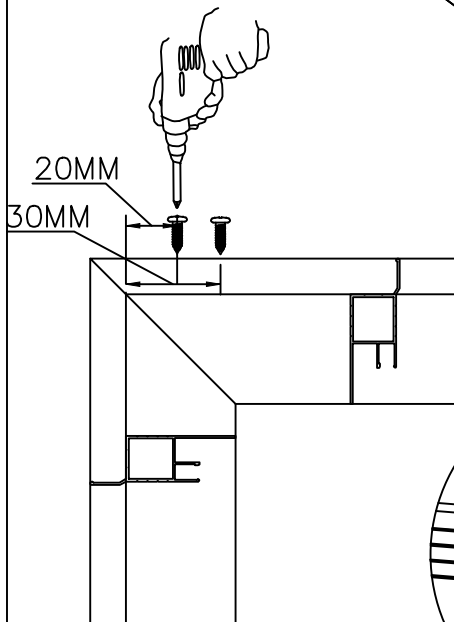
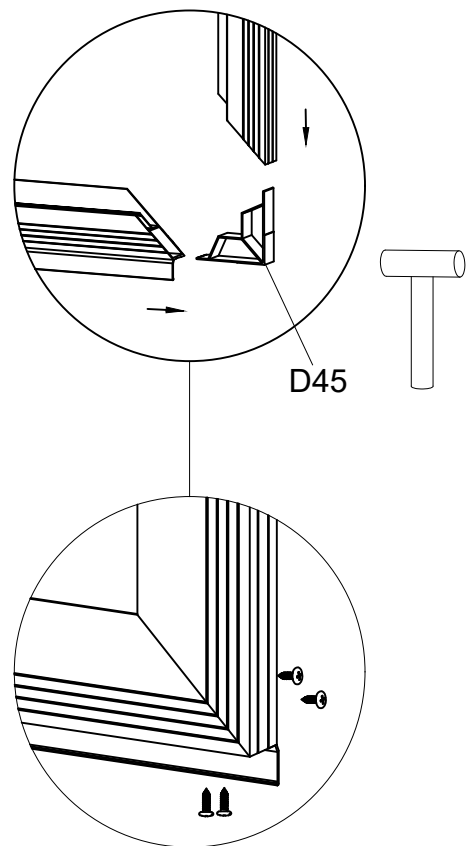

Attention! When installing the D45, you need to use a rubber mallet to lightly tap the snap into.

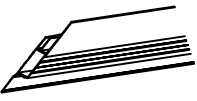
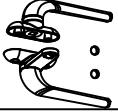

Step 4



Insert Connector D45 into each end of frame profiles L16B & L18A & L18B & L18D, and then fix them with screws Z08. fixing with screws, and make sure there is no gaps between each profile.

PART	NO	QTY
	L16A	1
	L17	2
	L18A	1
	L18B	1
	L18C	1
	H152	1
	D45	4
	D47	1
	S26	8
	M5X12	
	S76	2
	M4X32	
	Z08	16
	M4.2X16	
	Y11	3

Right Door

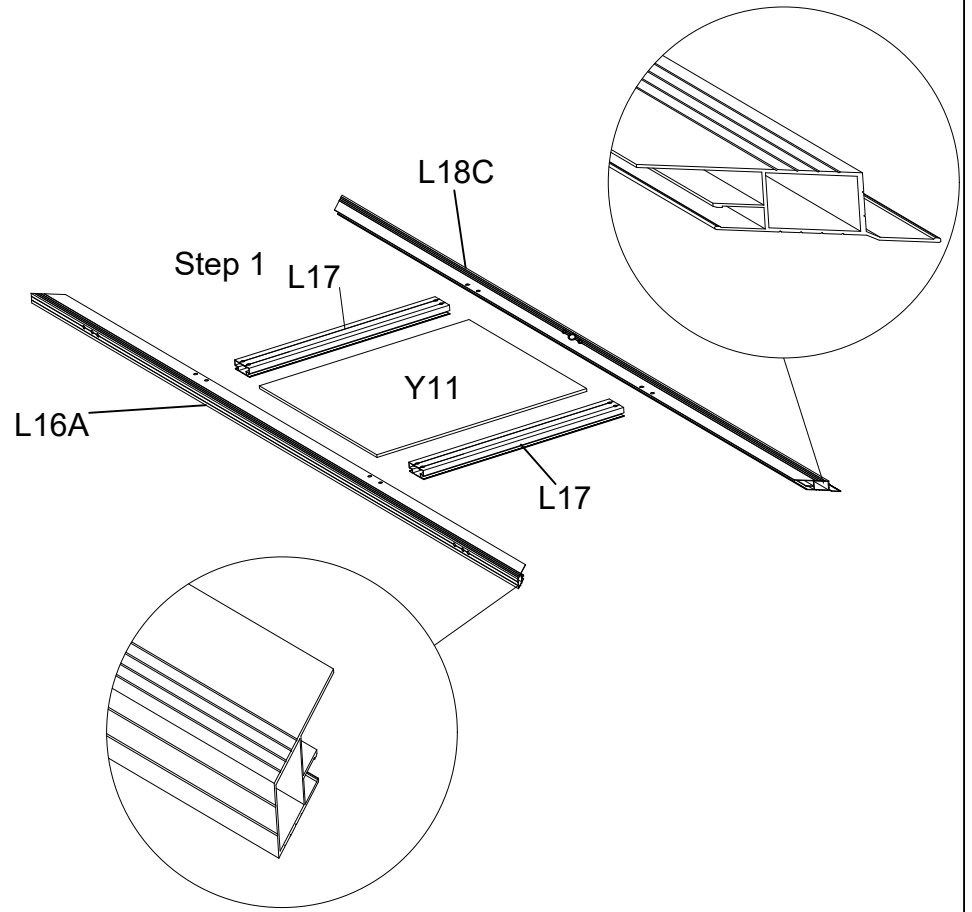

! Attention: Check the direction of the accessories

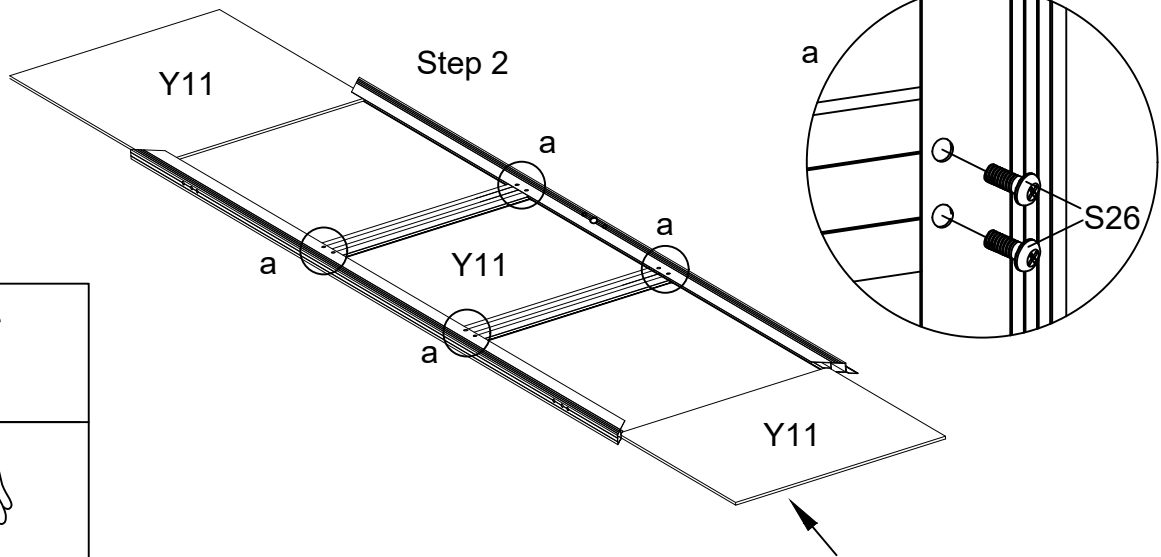

! Attention: Remove the protective films from both sides of each polycarbonate panel, before inserting into aluminum channels. Ensure the milky white film faces towards the Sun.

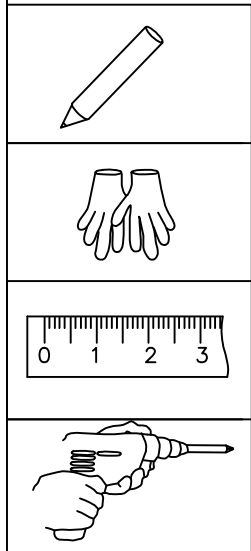

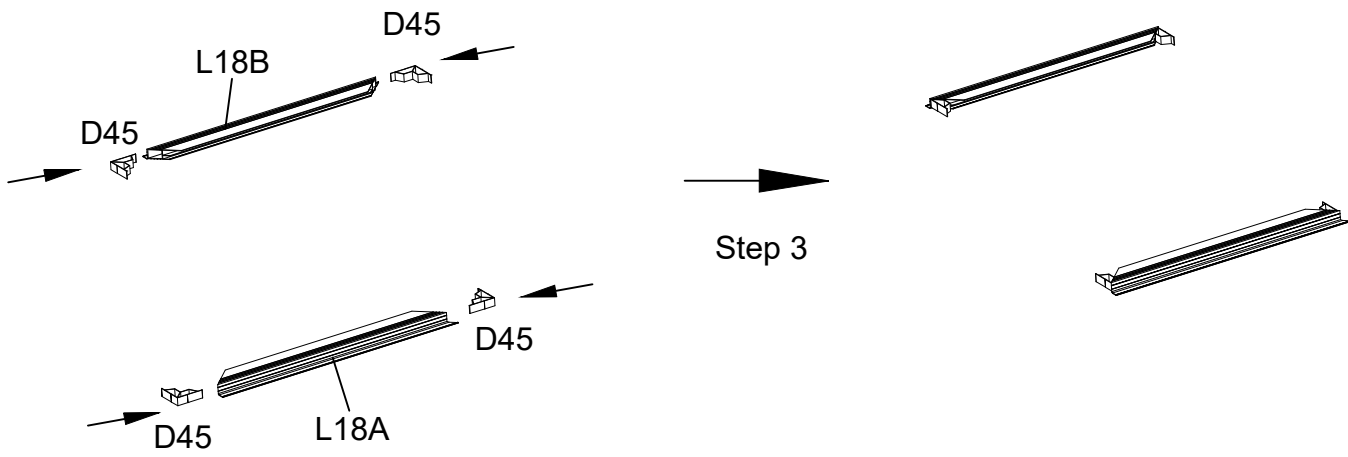

Attention! When installing the D45, you need to use a rubber mallet to lightly tap the snap into.

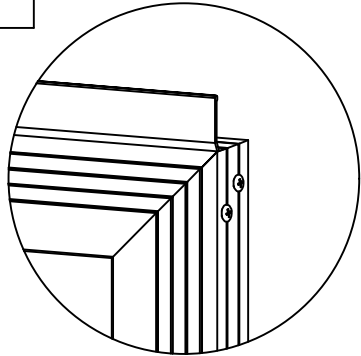
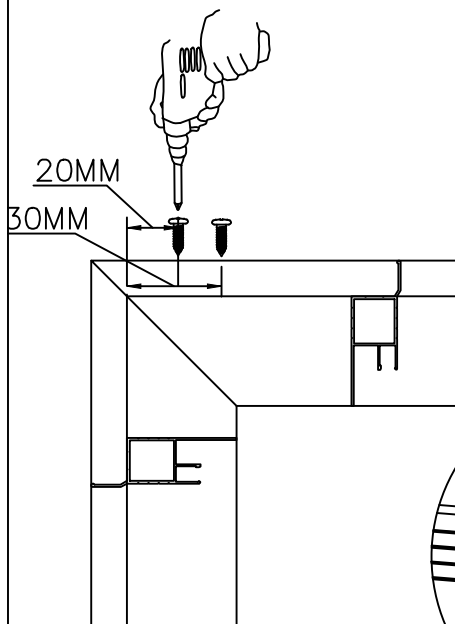
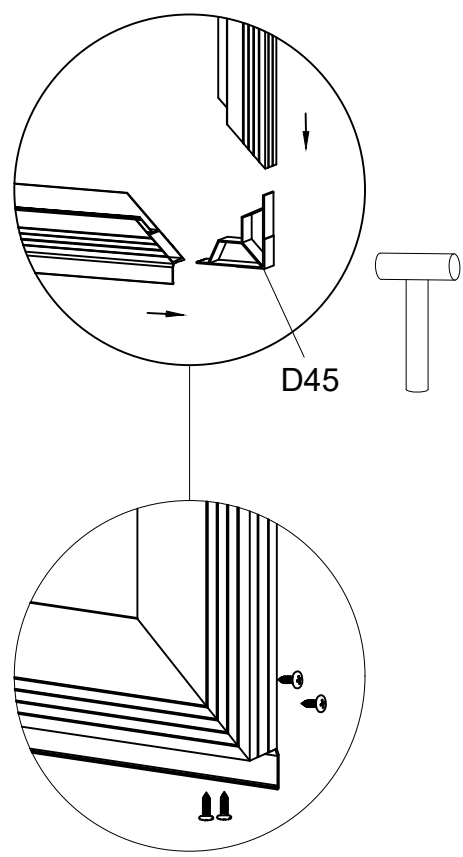
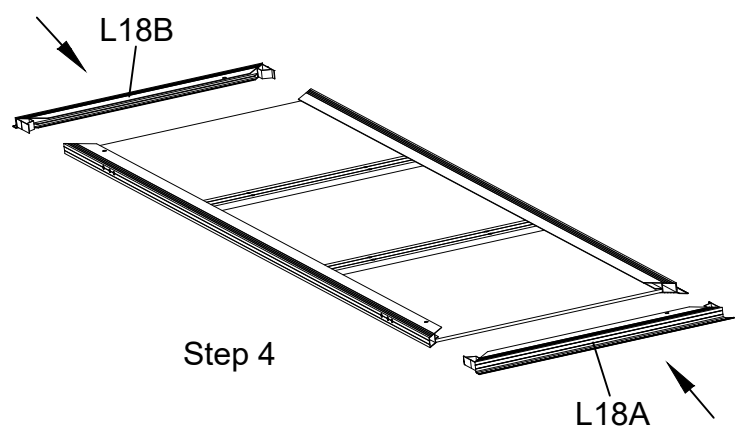

Insert Connector D45 into each end of frame profiles L16B & L18A & L18B & L18D, and then fix them with screws Z08. fixing with screws, and make sure there is no gaps between each profile.

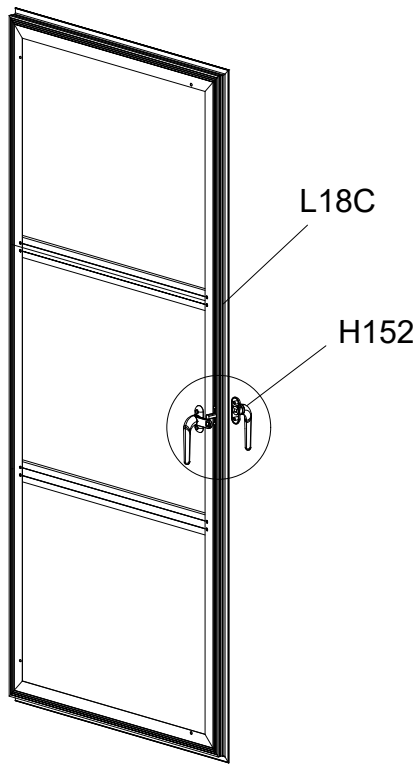





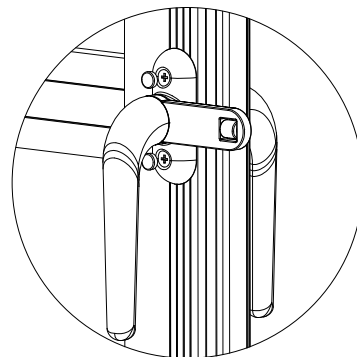
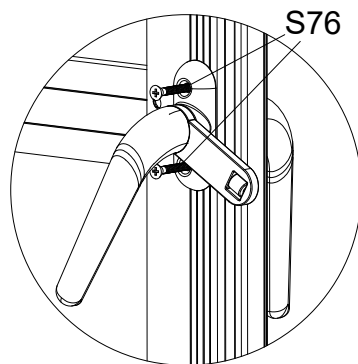
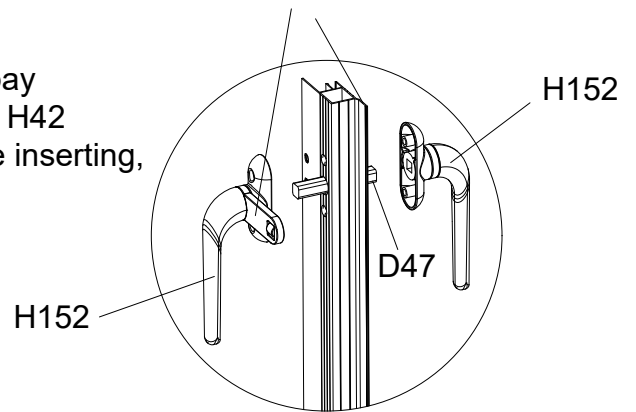

Pay attention to the installation direction

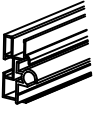
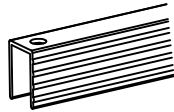
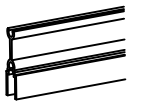
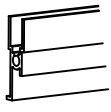
Install H152 after installing the door, when installing, pay attention to the H152 long end toward the door edge, H42 square hole aligned with the square column D47 while inserting, placed in the right position and then fixed with S76, and finally installed on the decorative cover







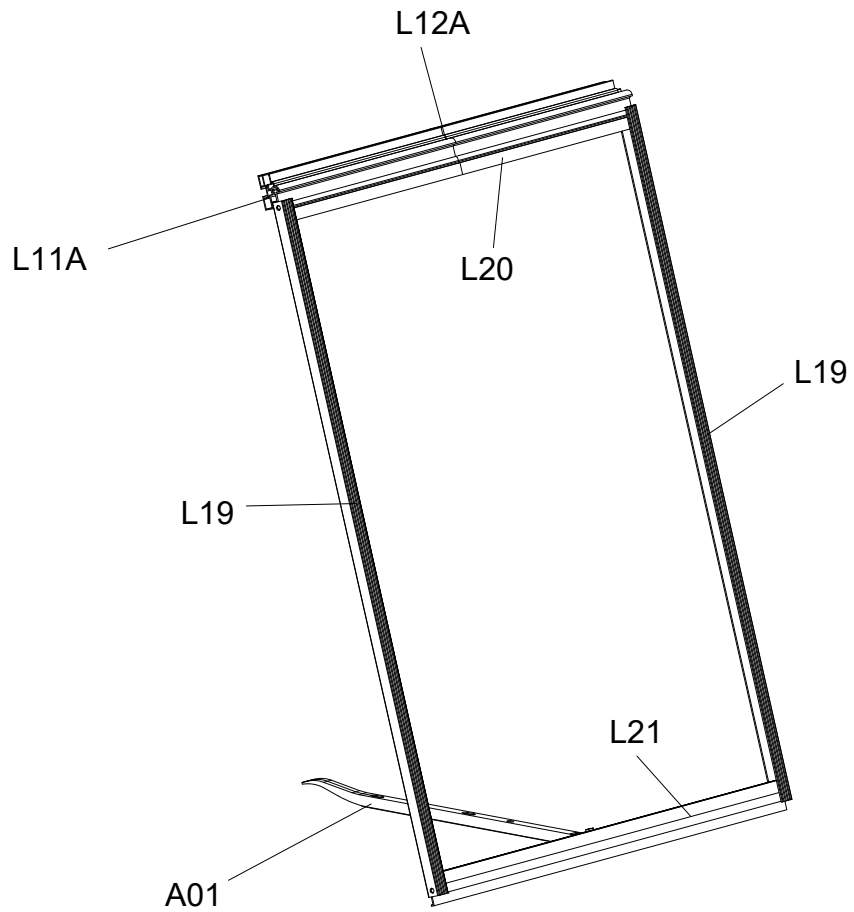

Exploded View

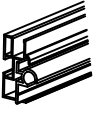
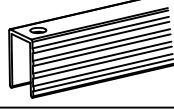
PART	NO.	QTY.
	L11A	4
	L19	8
	L20	4
	L21	4
	Y10	4
	A01	4
	Z02 Ø4X16D	24
	Z04 Ø4X8	8
	Z08 M4.2X16	8

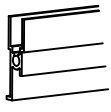
Window X 4



PART	NO.	QTY.
	L11A	1
	L19	2
	L20	1
	L21	1

Part	NO.	QTY.
	Y10	1
	A01	1
	Z02 Ø4X16D	6
	Z04 Ø4X8	2

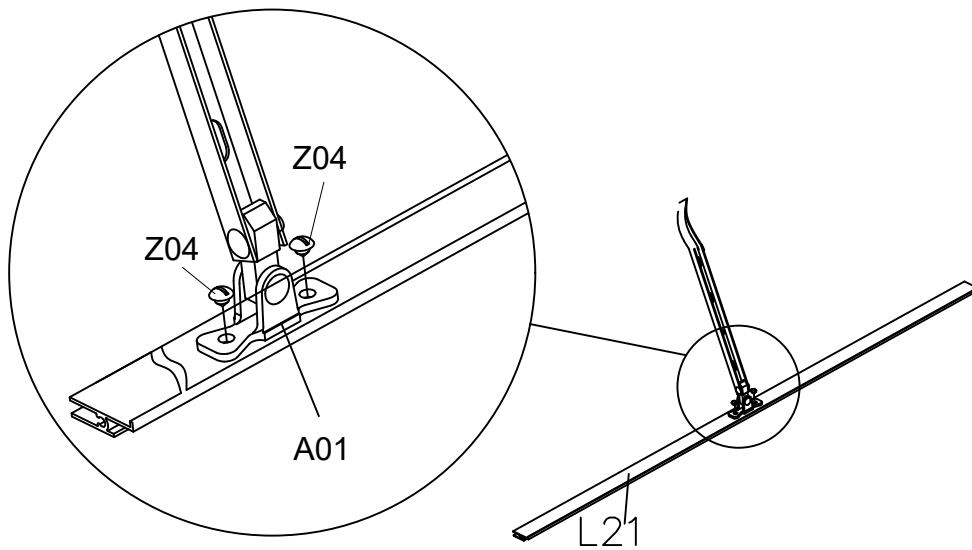

Step 1

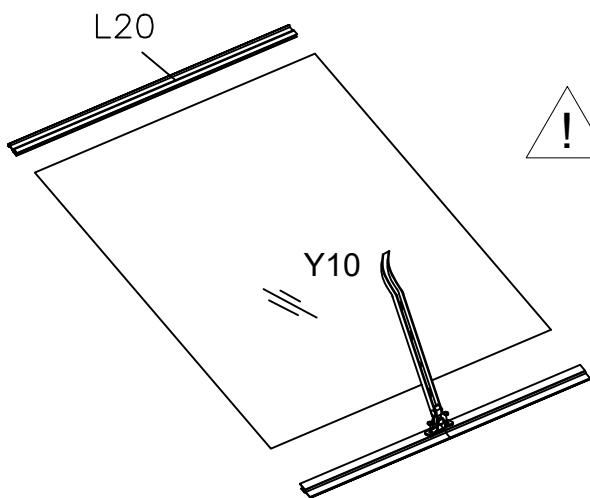







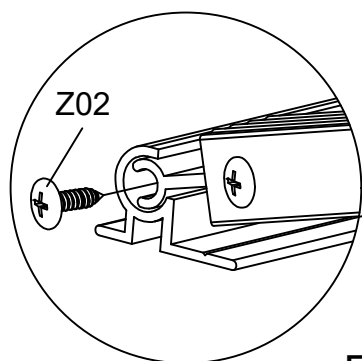
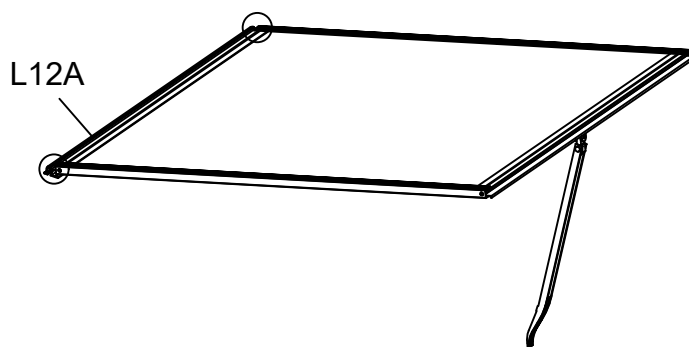
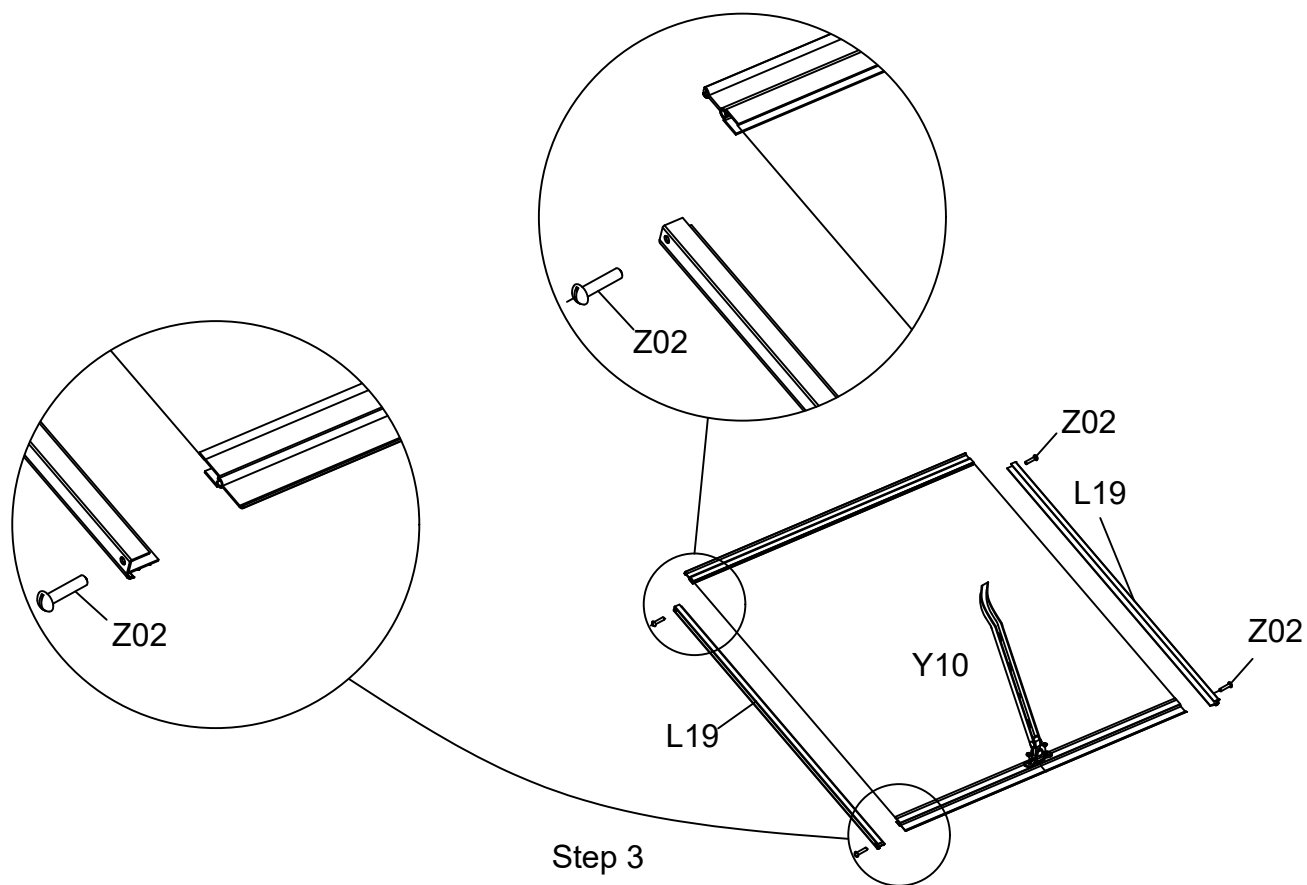

Step 2



! Attention: Remove the protective films from both sides of each polycarbonate panel, before inserting into aluminum channels. Ensure the milky white film faces towards the Sun.



Four windows are standard

PART	NO	QTY
	A2	2
	C2	4
	C3	2
	D2	2
	D306	4
	D307	5
	S01 M6X12	36
	M01 M6	36

Base Assembly

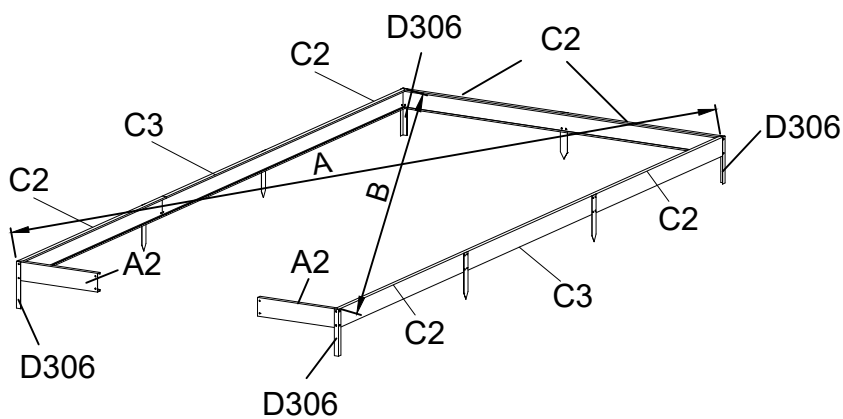
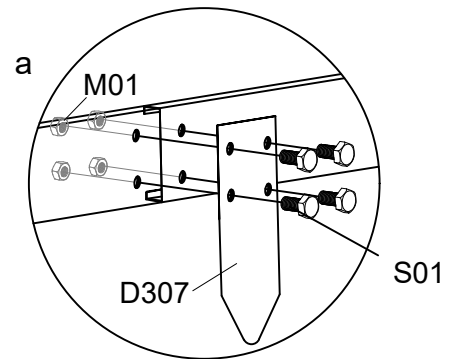
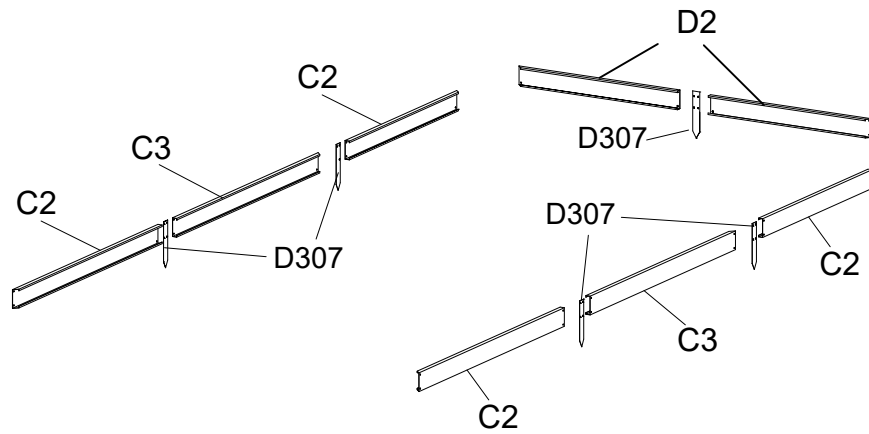

Attention! D306 and D307 must be inserted into the soil or installed in reverse!

Ⓐ = Ⓑ

Fix the base before assembly the greenhouse. This is the way to fix the base.

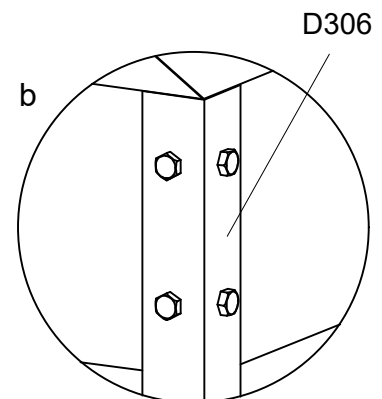



Base Assembly

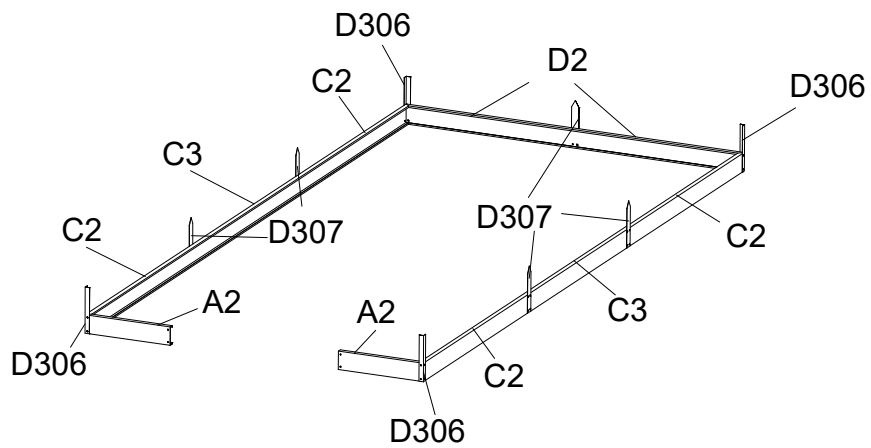

! Attention: Turn over the steel plinths D306 & D307 to complete the base installation as shown below, when the greenhouse is NOT inserted and secured into the soft soil.







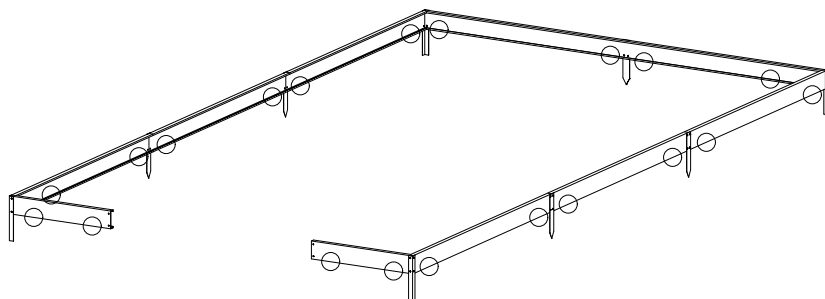

PART	NO	QTY
	D114	20
	S69 M6X60	20

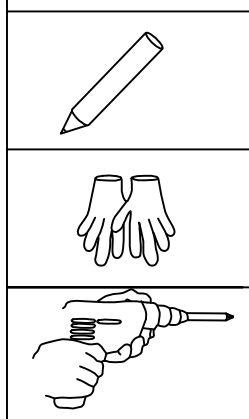
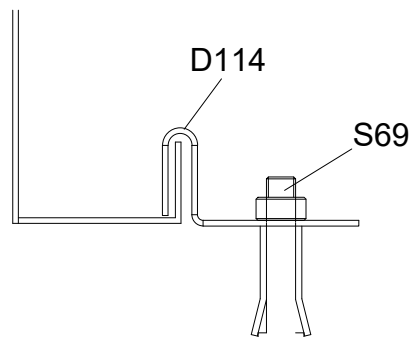
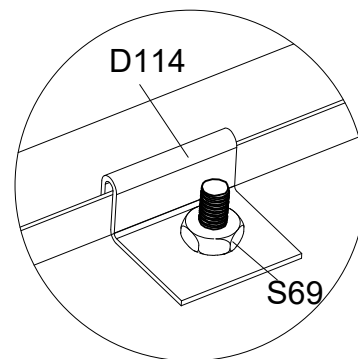
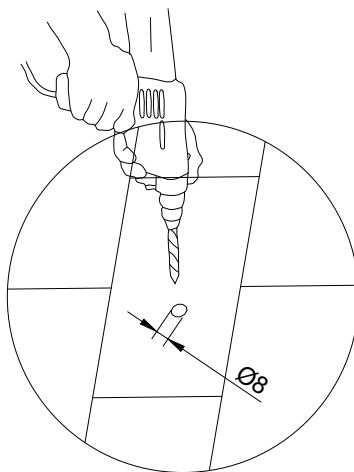
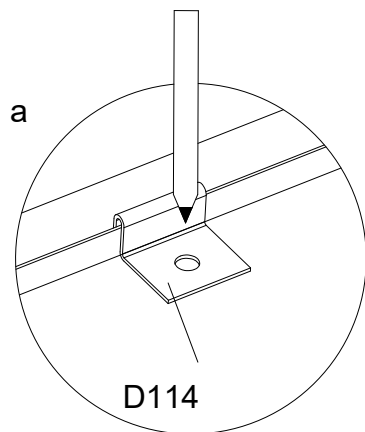
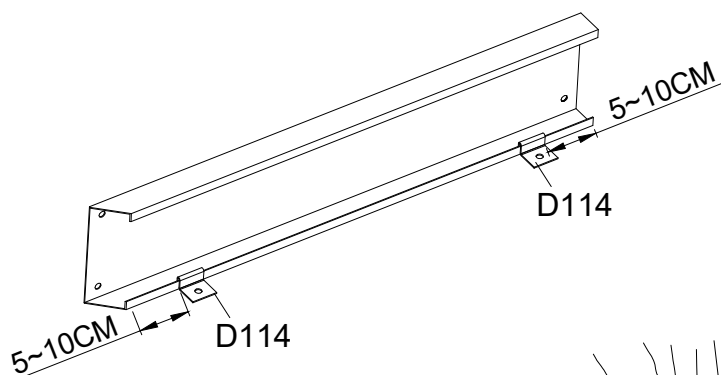
Base Assembly

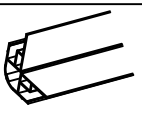

1. Fix the base anchor clip D114 onto each base section with a distance of 5~10CM from each end.
2. Mark the middle of the D114 hole to drill the $\text{Ø}8$ hole, then use S69 to fix the D114 to the ground



PART	NO	QTY
	L01E	1
	L01F	1
	L08C	2
	L10A	2
	L10B	1
	S01	4
	M6X12	
	M01	4
	M6	
	Z08	10
	M4.2X16	

Wall Assembly

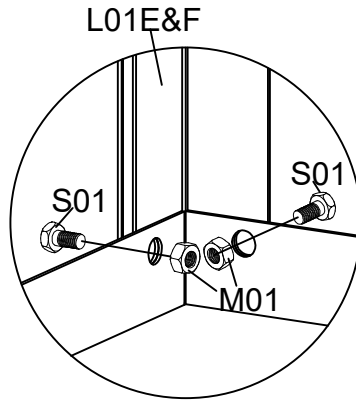

Different distance

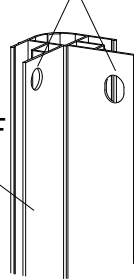

L01E&F

L10A

L10B

Line up from inside

Attention! L01E,L01F holes with different distances should be installed facing upwards.

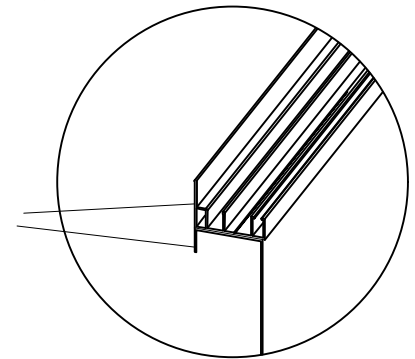

Make sure they line up from inside with the base plinth before fixing them with Z08

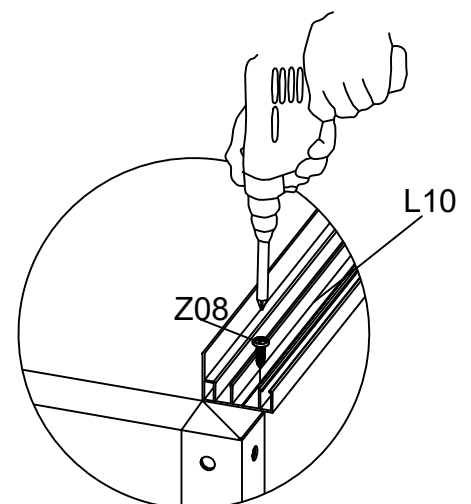
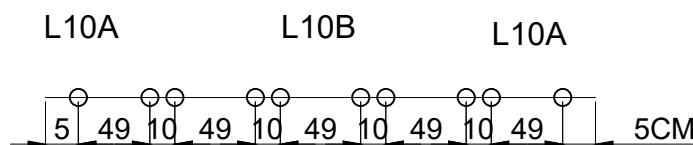
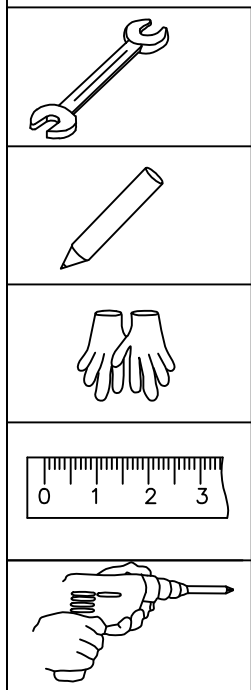

1. Place L10A, L10B, L01E, L01F & L08C on the base plinth (B2 & C2), then fix them together using S01 & M01 as shown. Make sure they line up from inside of the base plinth.
2. Use a powered screwdriver to fix the self-tapping screws (Z08) through the cills (L10A, L10B & L08C) and base plinth (B2,C2 and A2). The screws should be evenly spaced to ensure a neat appearance. The recommended spacing of the screws is 490mm. You can mark the painted surfaces with a pencil.



Wall Assembly



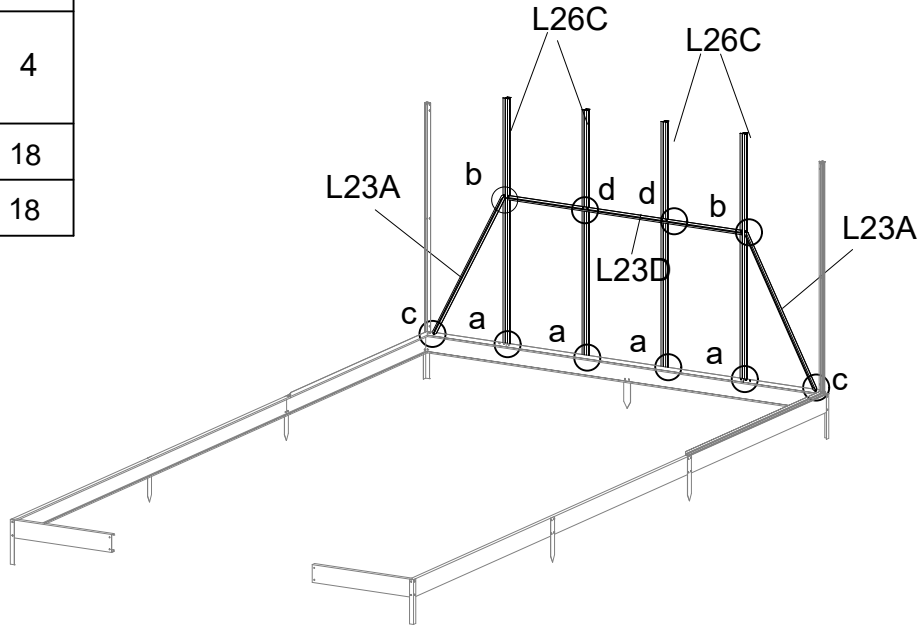

PART	NO	QTY
	L23A	2
	L23D	1
	L26C	4
	S01 M6X12	18
	M01 M6	18

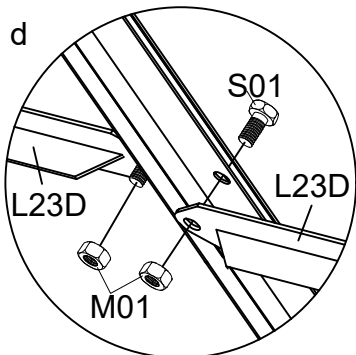
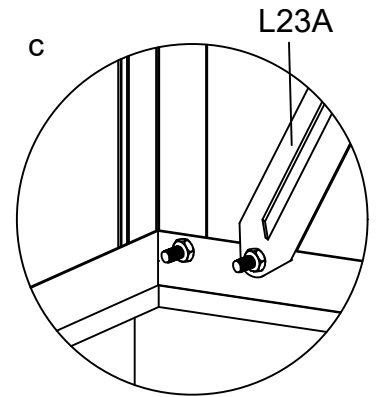
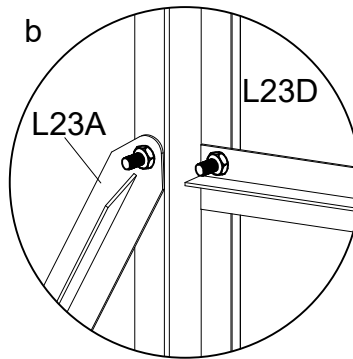
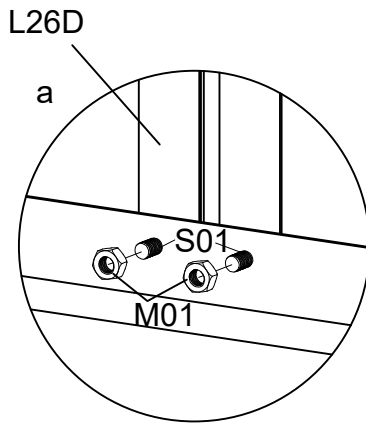

Fix L26D onto L10B, using S01 & M01.

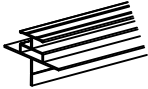
Fix L23A&L23D to L01E, L01F & L26C, using S01 & M01



PART	NO	QTY
	L03A	4
	L08C	4
	S01 M6X12	8
	M01 M6	8
	Z08 M4.2X16	24

Wall Assembly

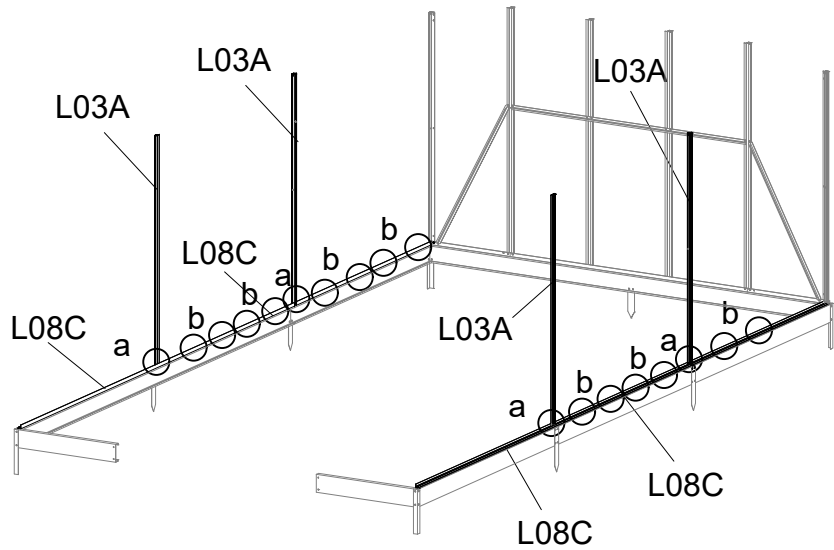

1. Place L08C on the base plinth and fix L03A onto L08C, using S01 & M01.
2. Use a powered screwdriver to fix the self-tapping screws (Z08) through the cills (L08C) and base plinth (C2). The screws should be evenly spaced to ensure a neat appearance. The recommended spacing of the screws is 490mm. You can mark the painted surfaces with a pencil.

Attention! : Install the L03A with the side with the hole facing up!

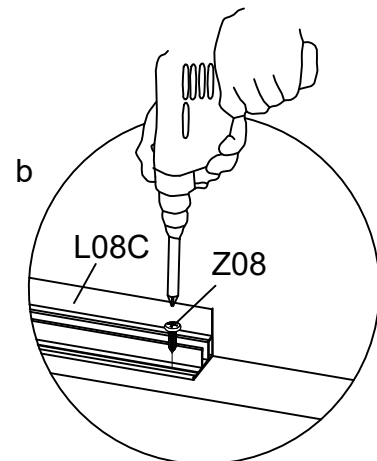
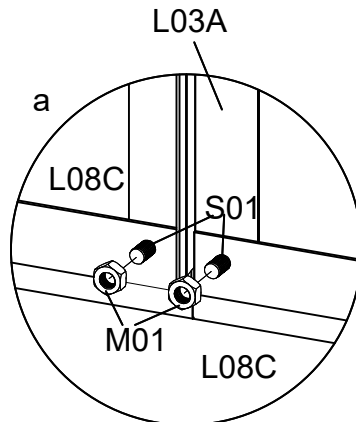
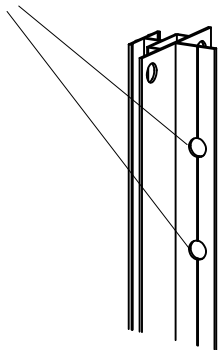

Z08 distances reference

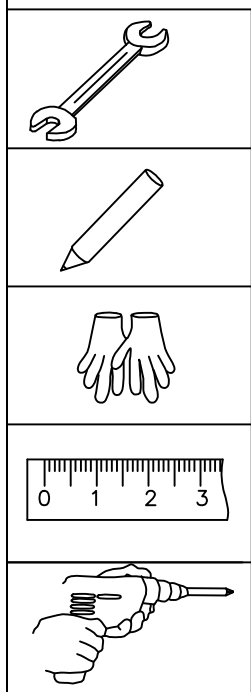

Wall Assembly

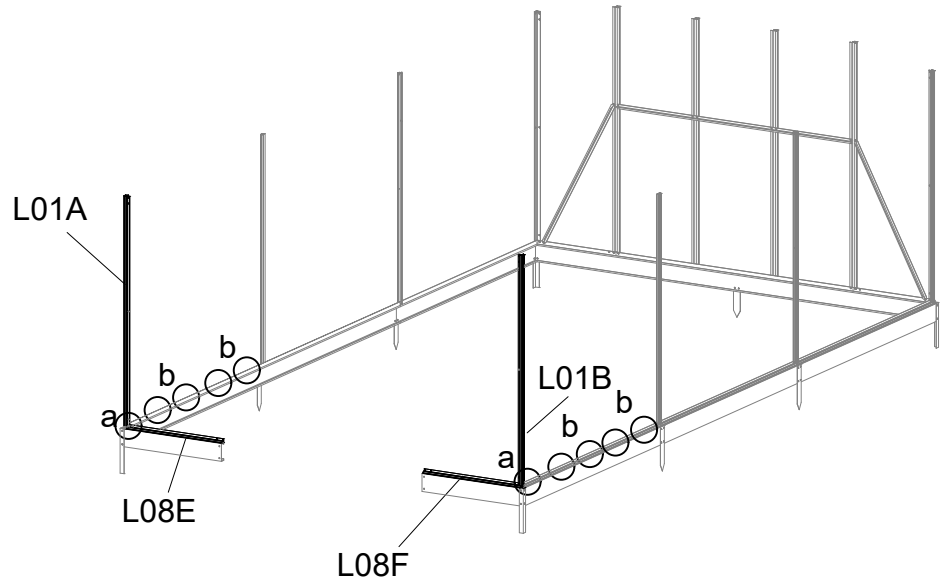

PART	NO	QTY
	L01A	1
	L01B	1
	L08E	1
	L08F	1
	S01 M6X12	4
	M01 M6	4
	Z08 M4.2X16	16

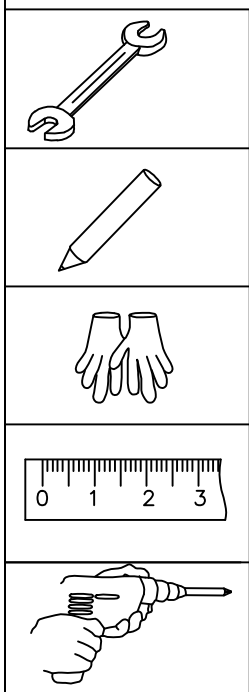
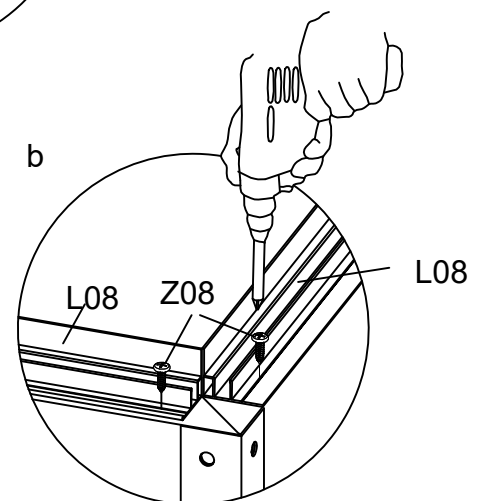
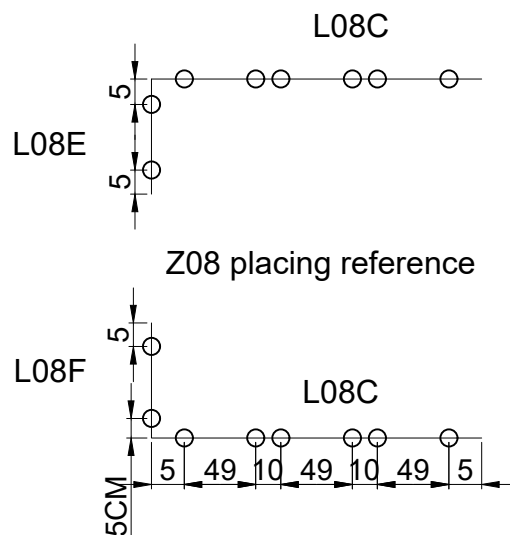
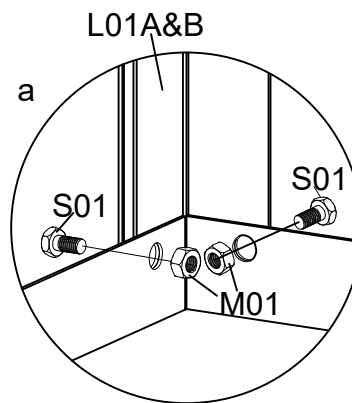

1. Place L08E & L08F on the base plinth and fix L01A & L01B onto L08C & L08E/L08F, using S01 & M01.
2. Use a powered screwdriver to fix the self-tapping screws (Z08) through the cills (L08C, L08E & L08F) and base plinth (A2 & C2). The screws should be evenly spaced to ensure a neat appearance. The recommended spacing of the screws is 490mm. You can mark the painted surfaces with a pencil.



Wall Assembly



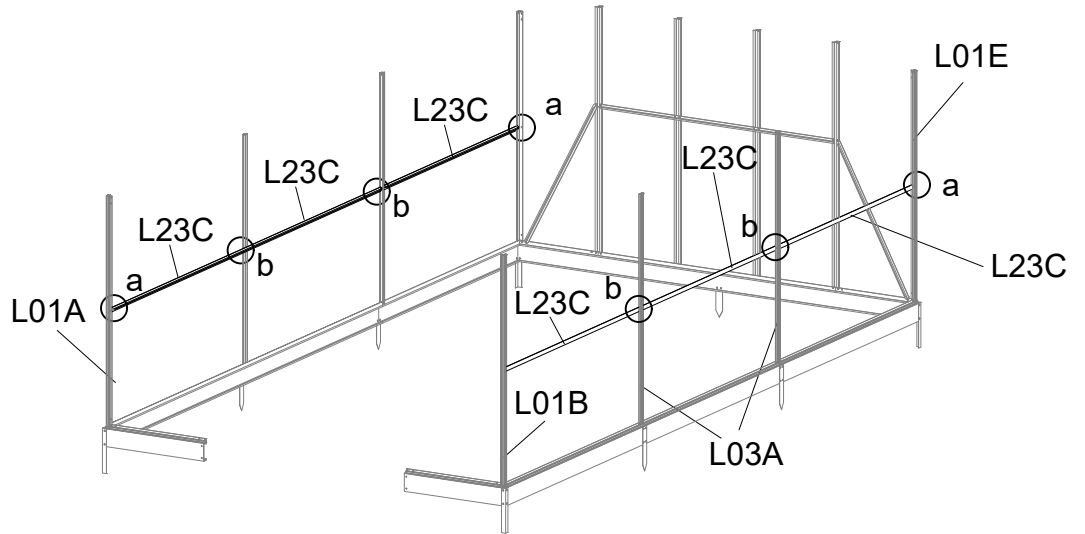

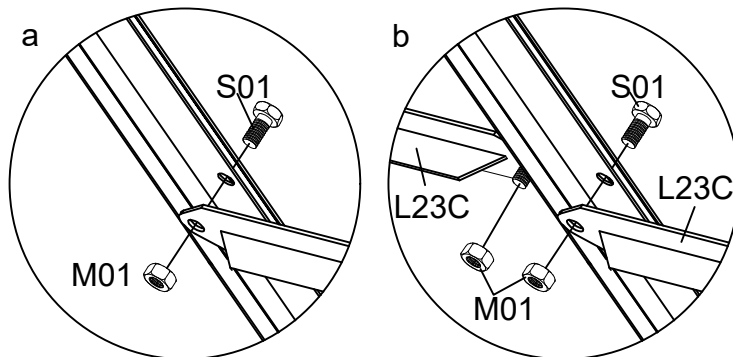

PART	NO	QTY
	L23C	6
	S01 M6X12	12
	M01 M6	12



Fix L23C * 4PCS onto L01A, L01B, L03A, L01E & L01F, using S01 & M01

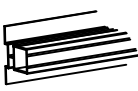

Wall Assembly

PART	NO	QTY
	L10C	1
	L23A	2
	L26A	1
	L26B	1
	D317	2
	S01 M6X12	12
	M01 M6	12
	S26 M6X12	4

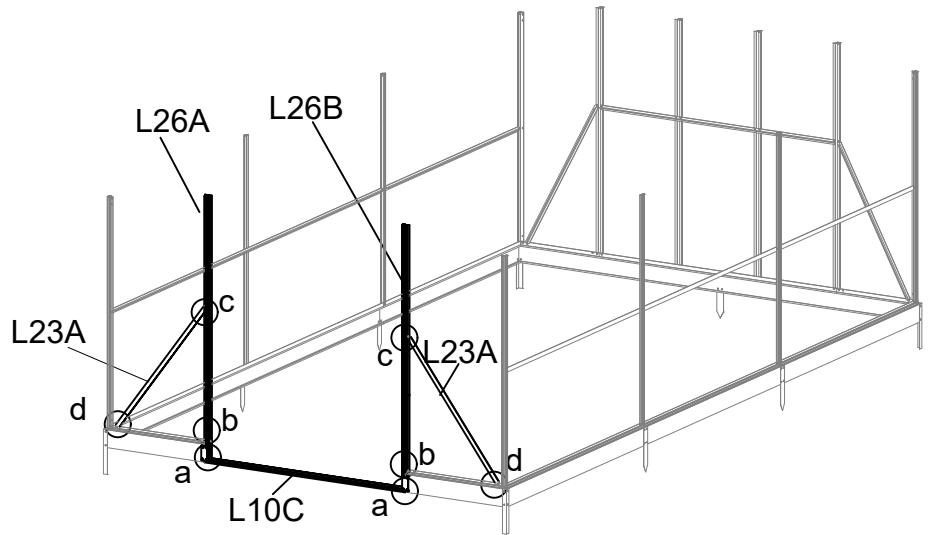

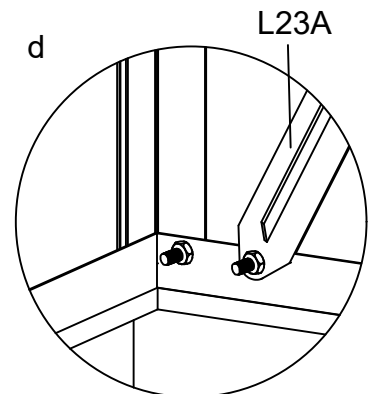
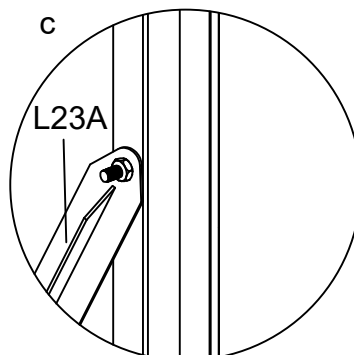
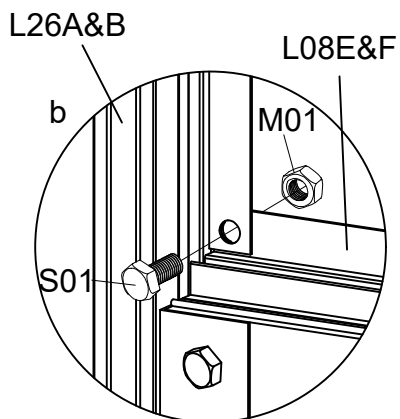
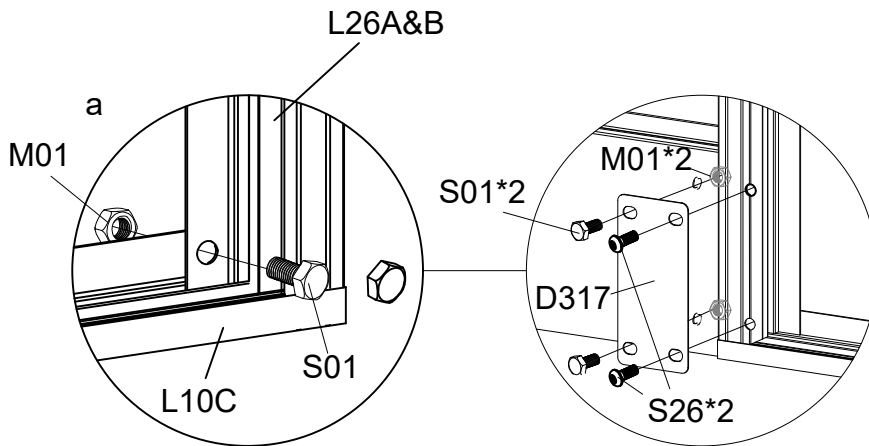

Fix L26A onto L08E,
L26B onto L08F using S01 & M01

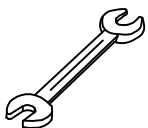

Fix L23A * 2PCS onto L01A & L26A
/L01B & L26B, using S01 & M01.





Wall Assembly

PART	NO	QTY
	L07C	6
	S01 M6X12	12
	M01 M6	12

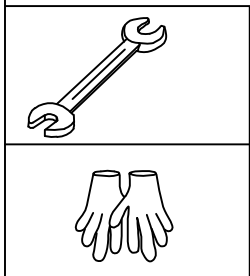
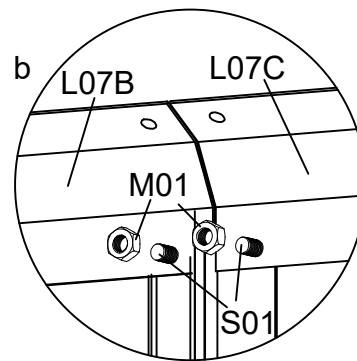
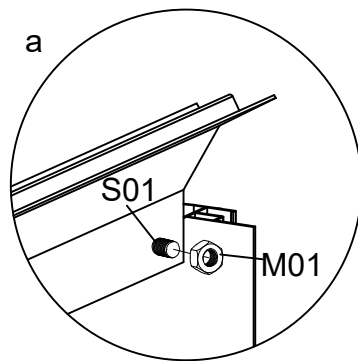
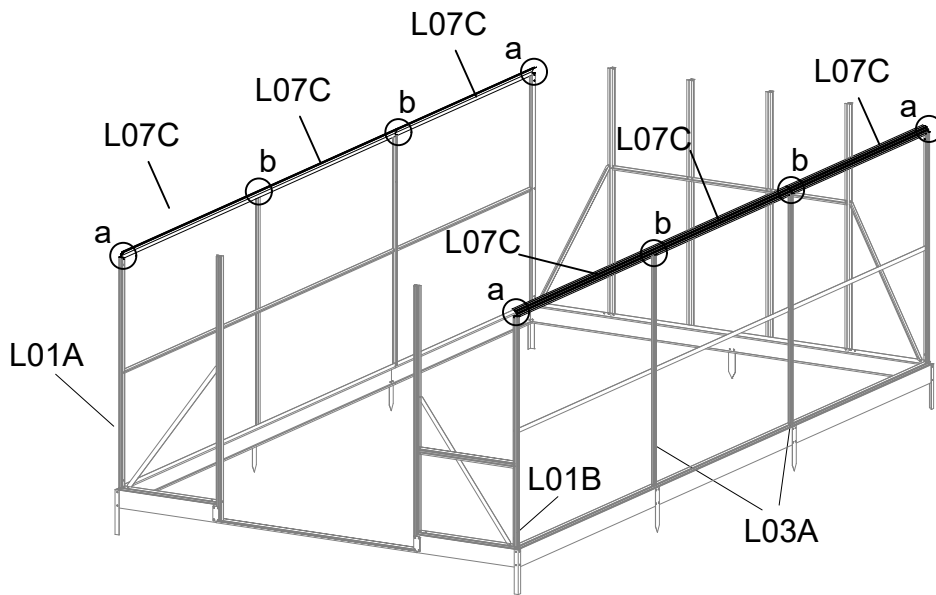
Fix L07C * 2PCS onto L01A, L03A & L01F and L01B, L03A & L01E, using S01 & M01



Wall Assembly

PART	NO	QTY
	L02A	12
	S01 M6X12	60
	M01 M6	60

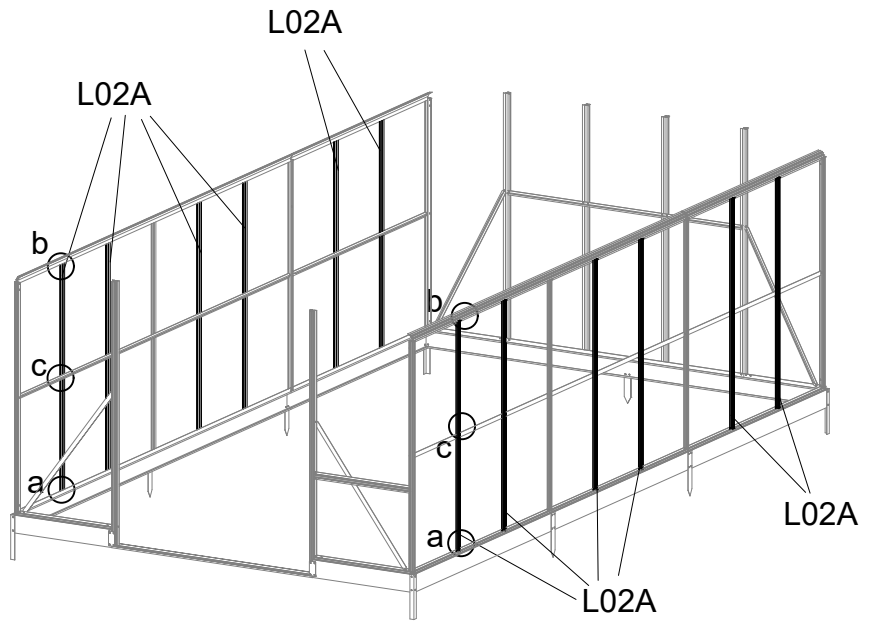



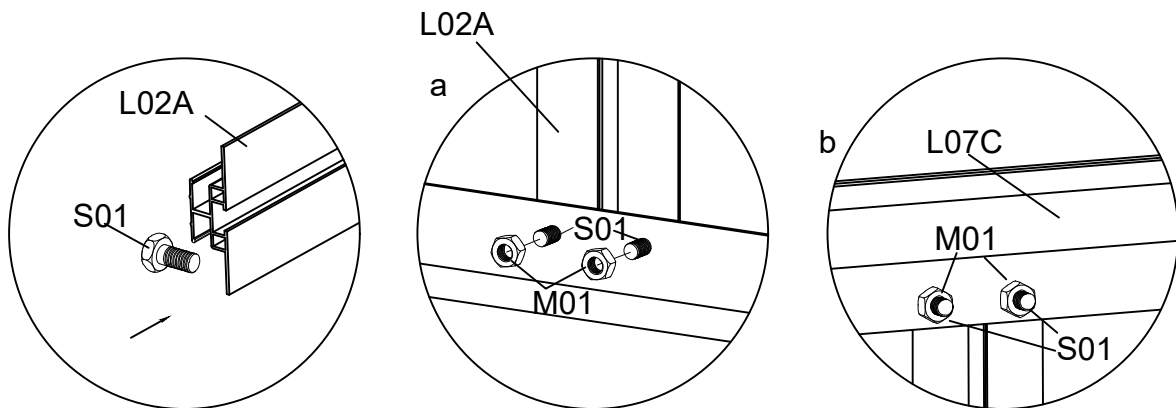

Fix L02A (8pcs) to L08C and L07C using S01 & M01.

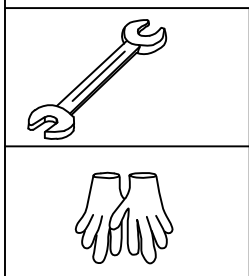
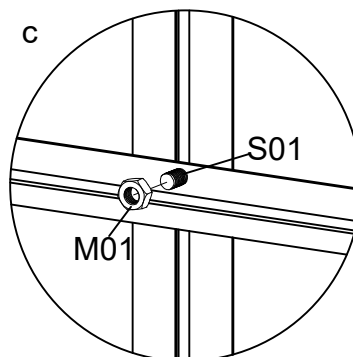

Slide a bolts (S01) into each L02A bolt channel. One is to fix L23C

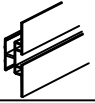

Wall Assembly



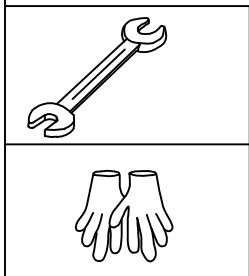
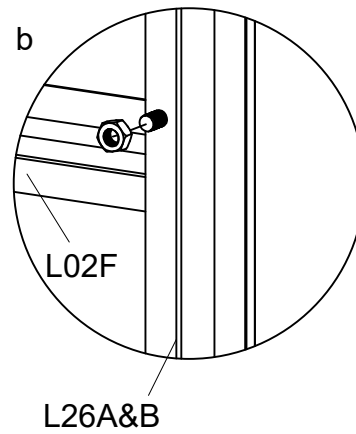
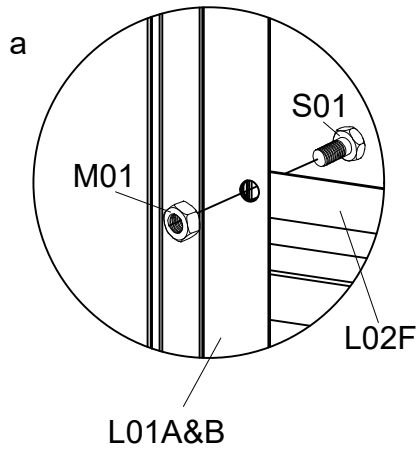
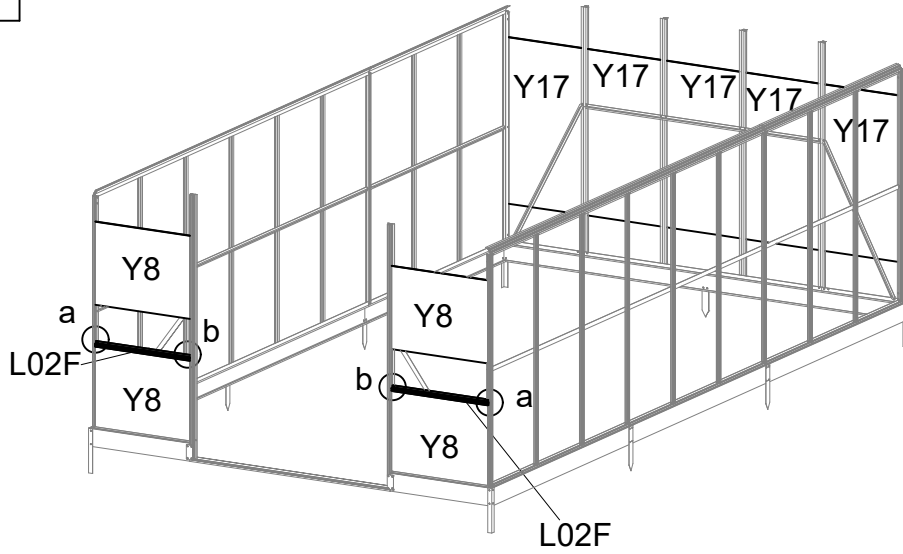





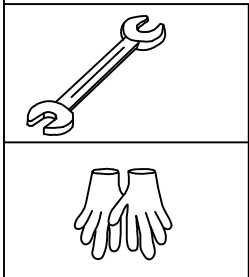
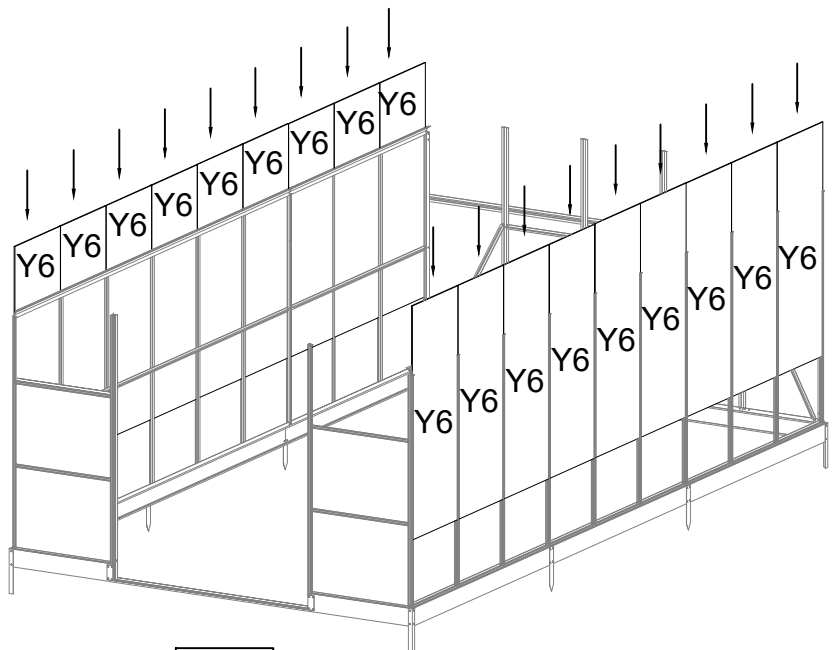
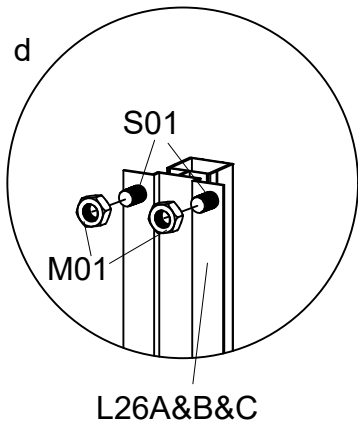
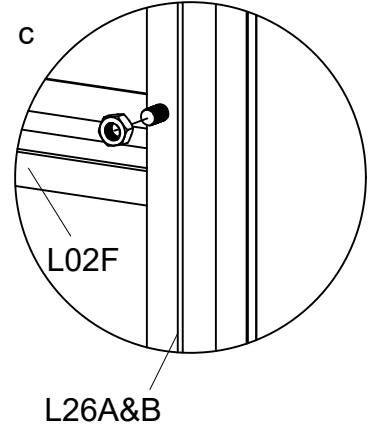
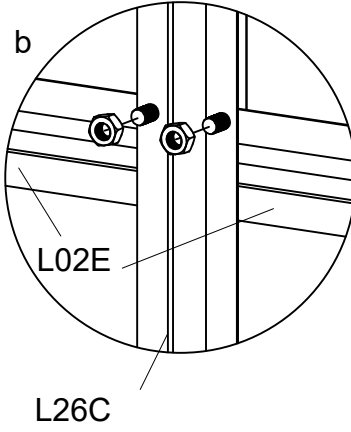
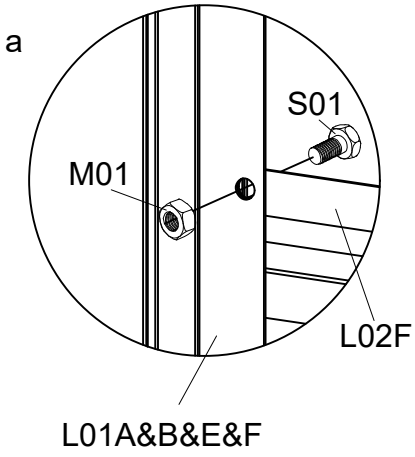
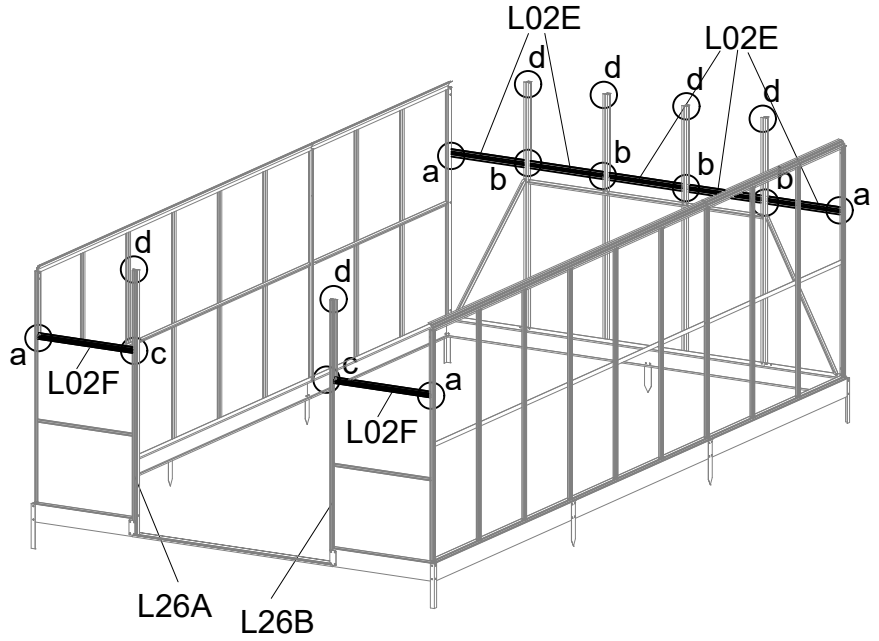

PART	NO	QTY
	L02F	2
	Y8	4
	Y17	5
	S01 M6X12	4
	M01 M6	4



Wall Assembly

PART	NO	QTY
	L02E	5
	L02F	2
	Y6	18
	S01	14
	M6X12	
	M01	14
	M6	



PART	NO	QTY
	L26D	1
	L26E	1
	L26F	1
	L26G	1
	Y4	1
	Y5	1
	Y14	1
	Y15	1
	Y18	3
	A114	2
	S01 M6X12	8
	M01 M6	8
	S26 M5X12	8

Put the panels into positions

Wall Assembly

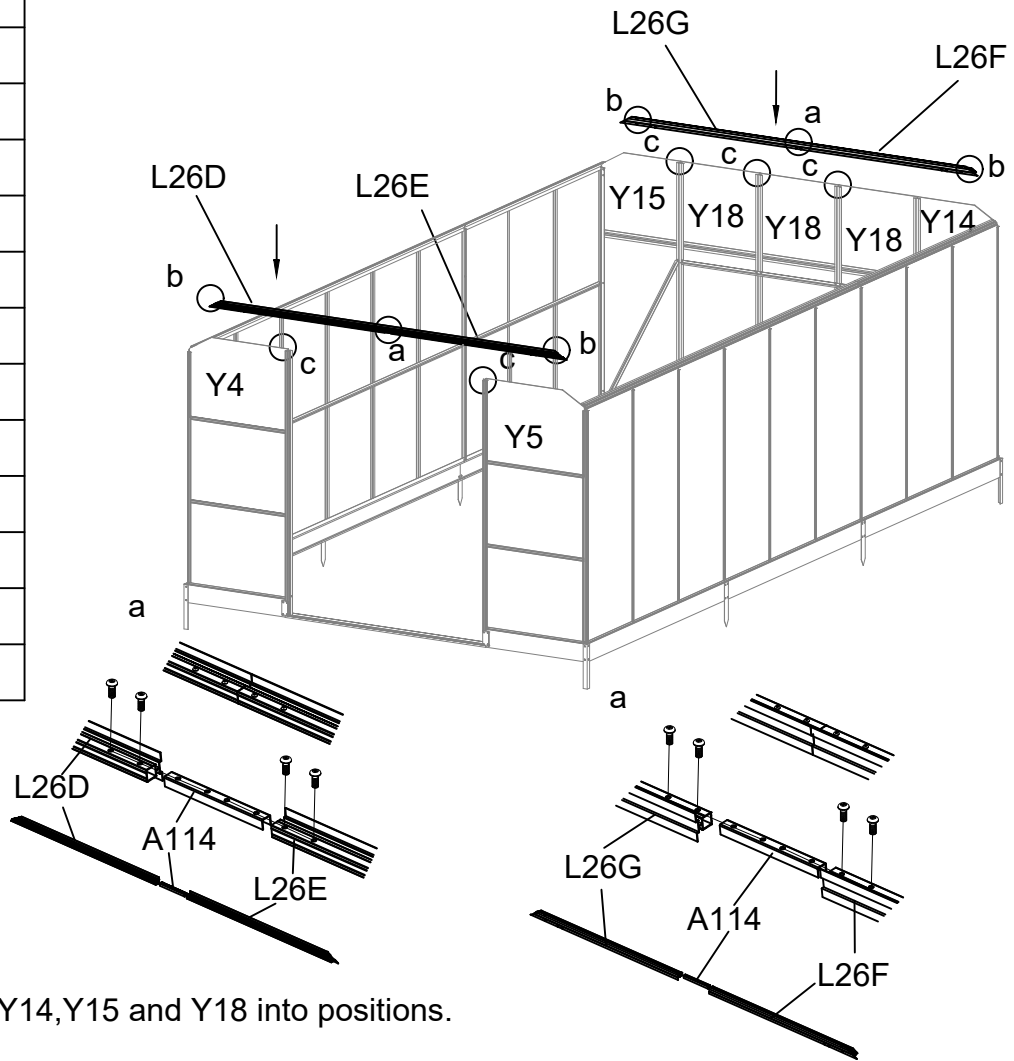

Put the panels Y4, Y5, Y14, Y15 and Y18 into positions.

! Attention:

Please pre-load S01 & M01 on L26D, L26E, L26F & L26G before putting panels Y4, Y5, Y14, Y15 & Y18 into position.

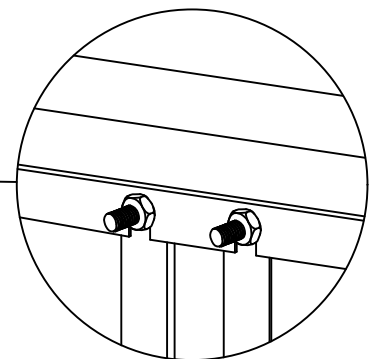
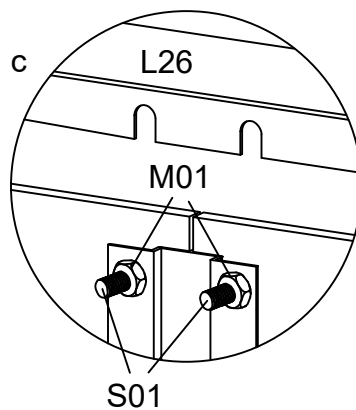
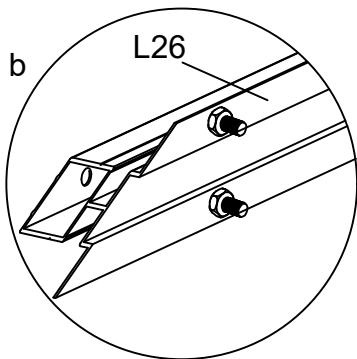

Loose the nuts M01 on L26C, L26D, L26E & L26F to allow L26C, L26D, L26E & L26F fitted in. After the screws are inserted into the U-shaped opening, it is necessary to adjust the structure and lock it.

PART	NO	QTY
	L02C	2
	L02D	2
	Y1	2
	Y2	2
	Y3	2
	S01 M6X12	16
	M01 M6	
	M01 M6	16

Top Assembly

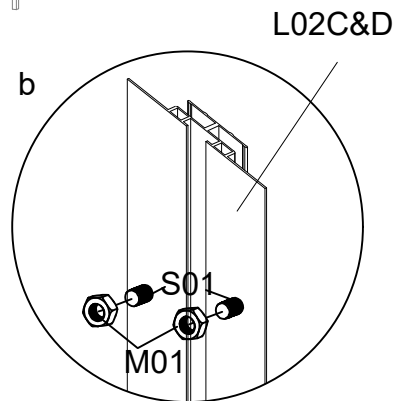
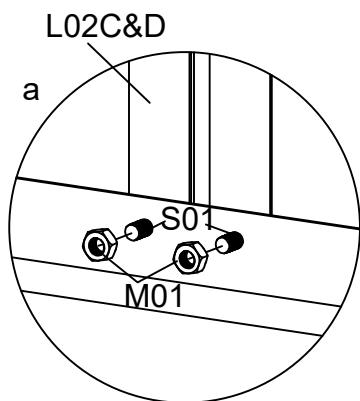
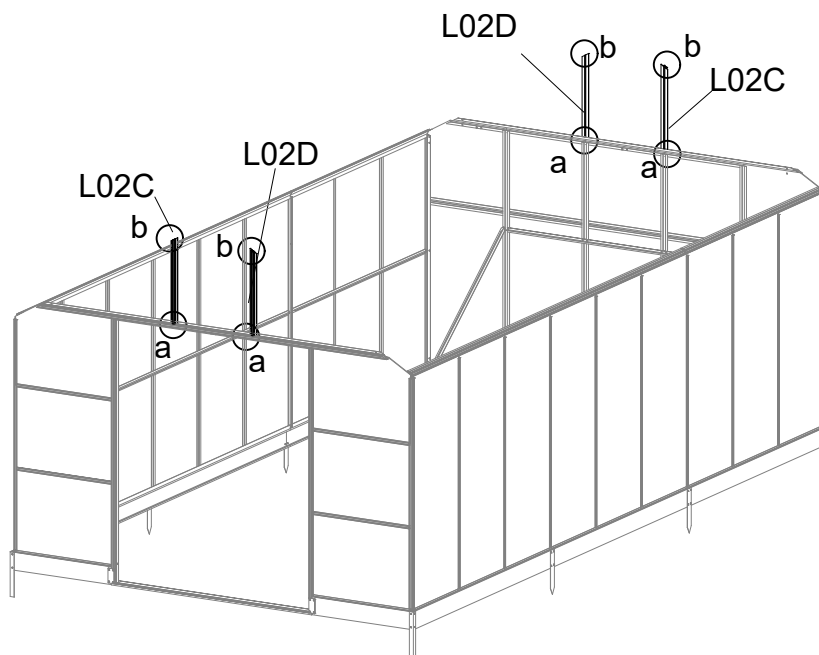

Preload S01 & M01 on L02C and L02D before fixing them to L01C/L01D. See figure b.







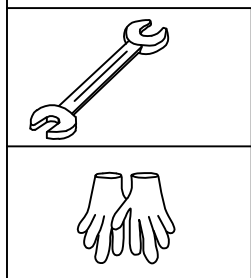
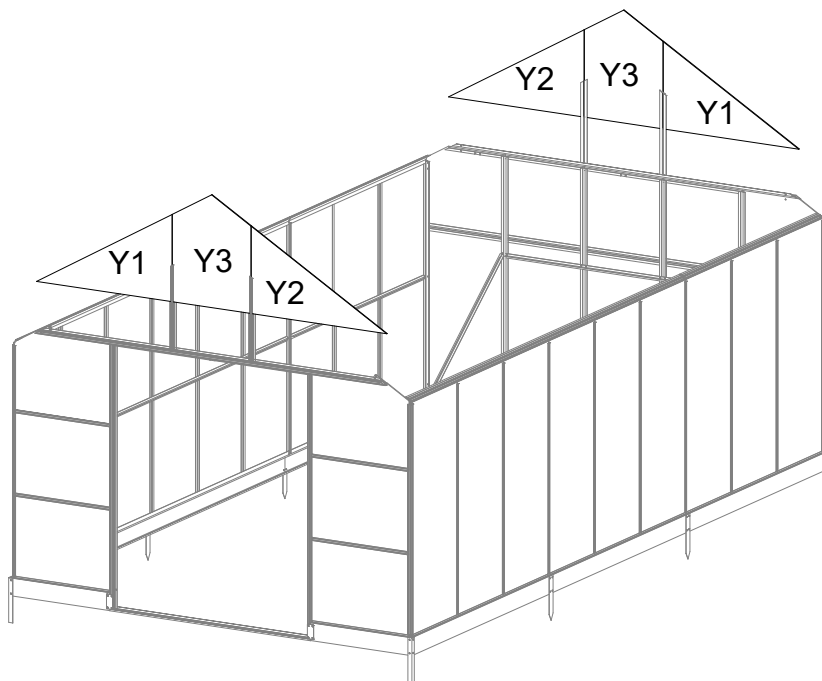

! Attention: Remove the protective films from both sides of each polycarbonate panel, before inserting into aluminum channels. Ensure the milky white film faces towards the Sun.

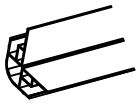
Put the glazing panels Y1, Y2 & Y3 into positions.



Top Assembly

PART	NO	QTY
	L01C	2
	L01D	2
	D17	2
	D38	4
	D309	4
	S01 M6X12	28
	M01 M6	28
	M01 M6	28

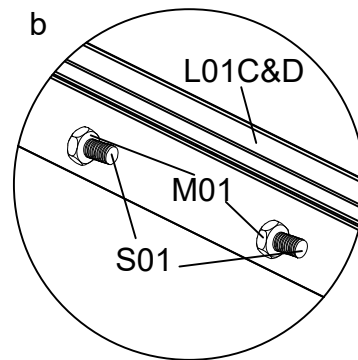
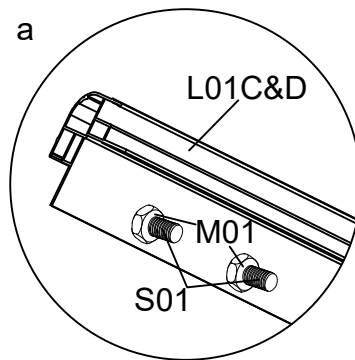
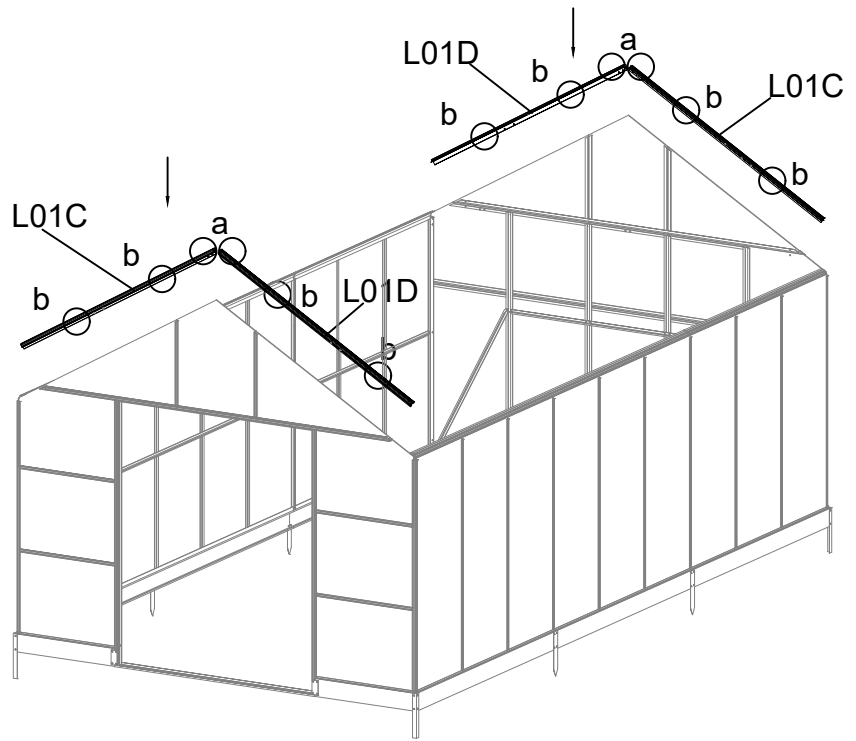

1. Preload S01 & M01 on L01C and L01D before fixing them to L01A/L01B. See figure a & b.

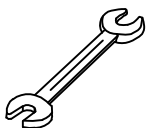

Top Assembly

If the holes are not aligned, it may be due to uneven foundation, adjust the foundation and frame to solve the problem

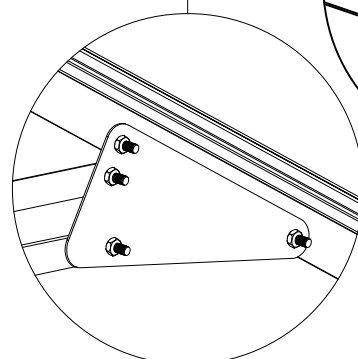
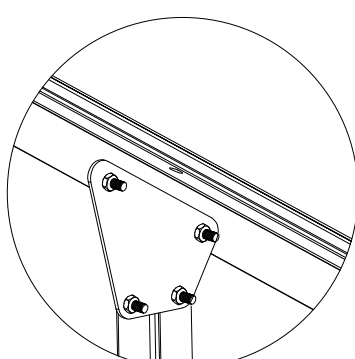
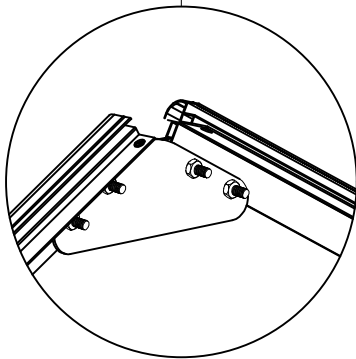
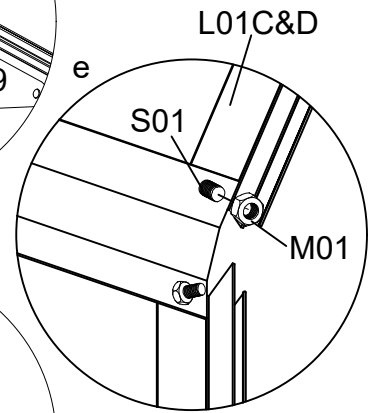
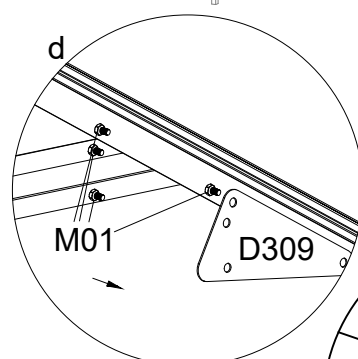
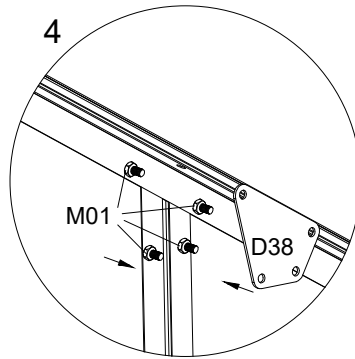
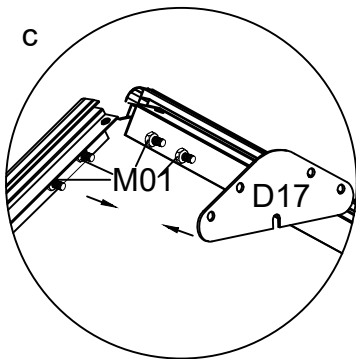
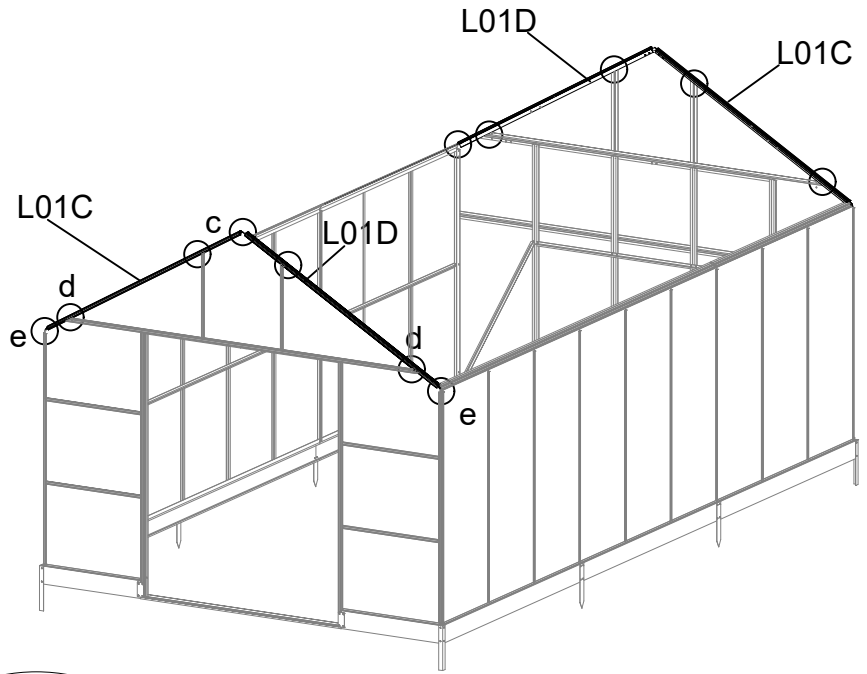



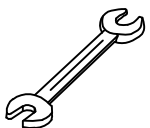

2. Bolt L01C and L01D with plate D17, using S01 & M01 preloaded. And then fix them to L02C, using S01 & M01.

3. Fix L01C & L01D to L26G & L26H with the plate D309, using the S01 and M01 preloaded above.

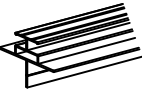
4. Fix L01C & L01D to L01A & L01B, using S01 & M01.



PART	NO	QTY
	L03B	4
	L23E	6
	D17	6
	S01 M6X12	44
	M01 M6	44

Top Assembly

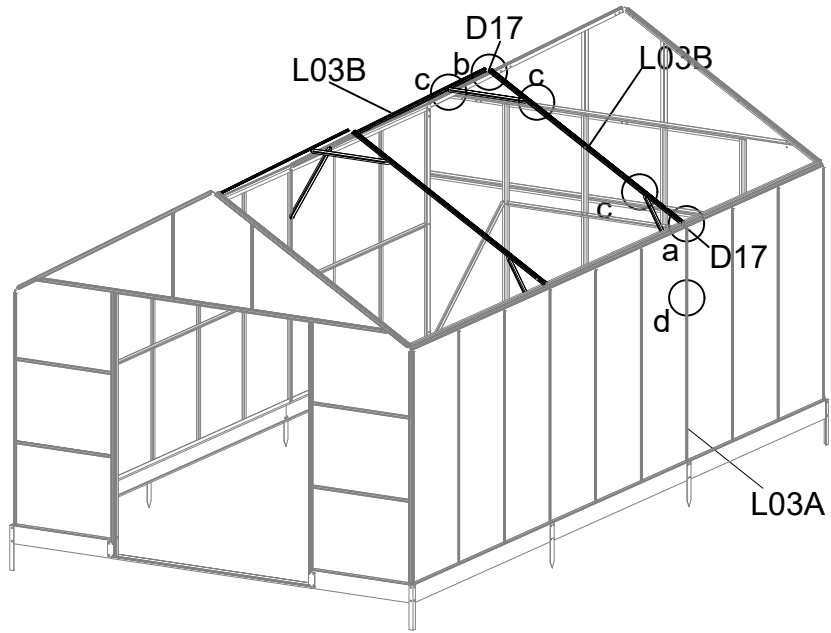

Fix plates D17 to L03A & L03B using S01 & M01.

Fix glazing bars L03B to the eaves and the ridge profiles using S01 & M01

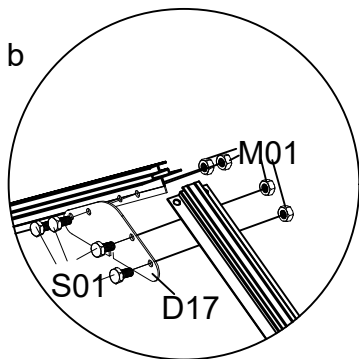
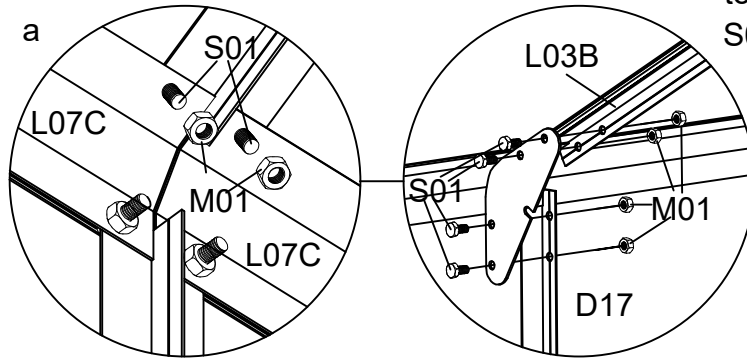

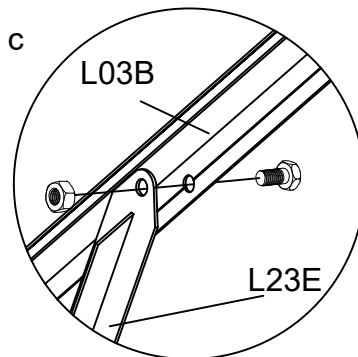

Fix plates D17 to the two L03B using S01 & M01.

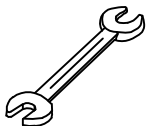
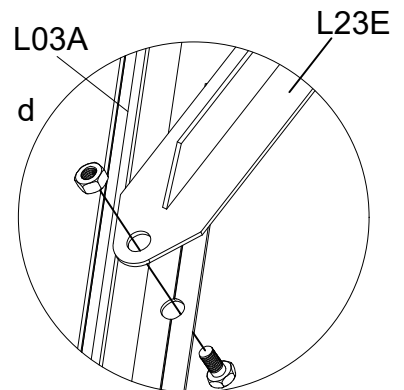

Fix L23E to L03A and L03B using S01 & M01.

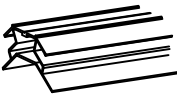

Top Assembly

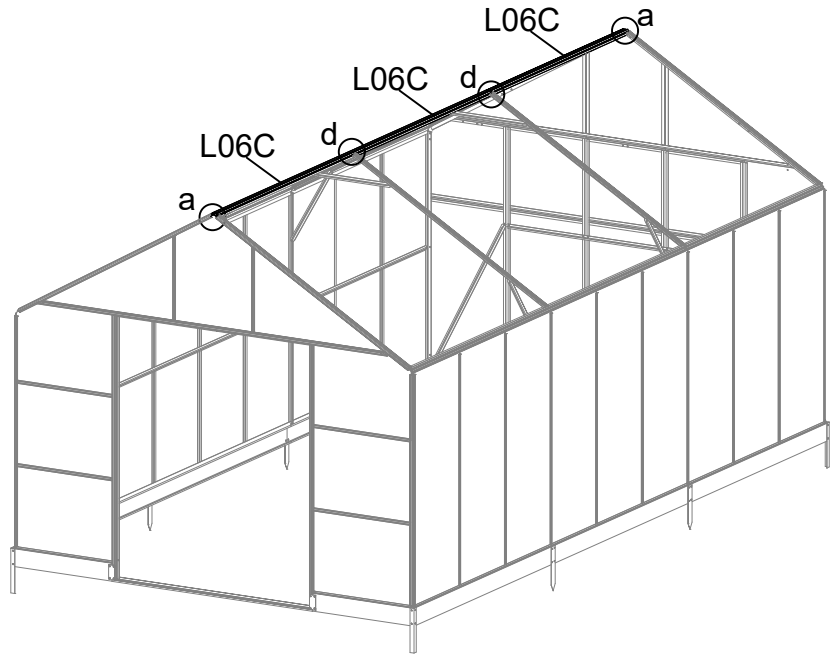

PART	NO	QTY
	L06C	3
	S01 M6X12	12
	M01 M6	12

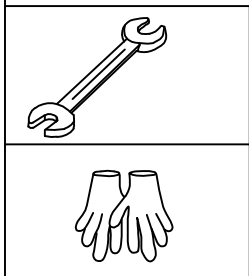
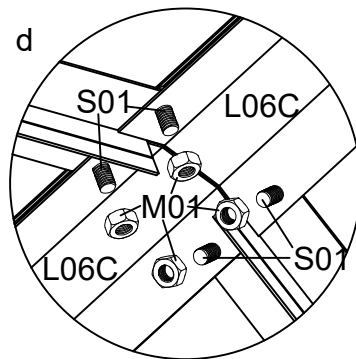
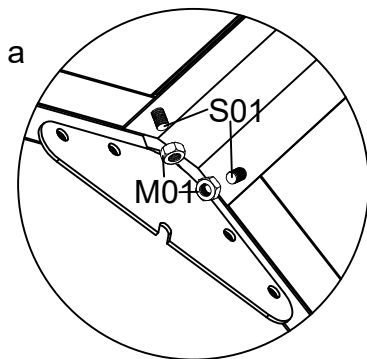

Bolt the ridge L06C (2pcs) to L01C, L01D and L03B, using S01 & M01.



Top Assembly

PART	NO	QTY
	L02B	12
	S01 M6X12	72
	M01 M6	48

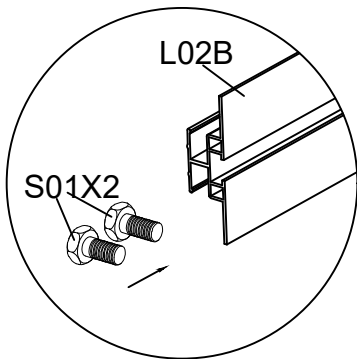
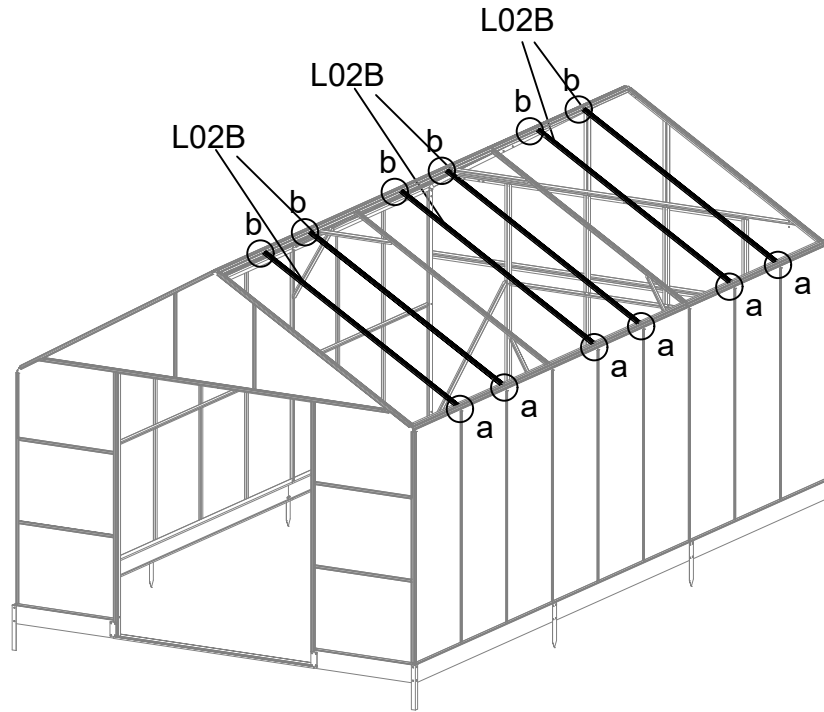



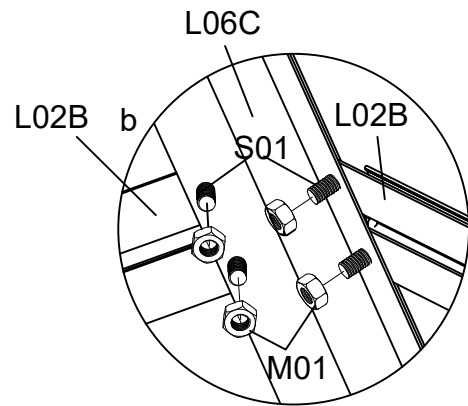
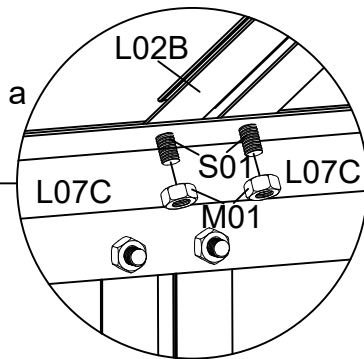

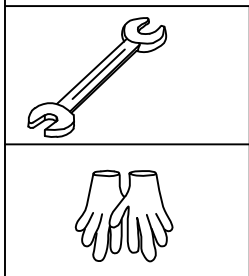

Slide 2 bolts (S01) into each L02B bolt channel to be used later.



Fix glazing bars L02B (8pcs) to the eaves and the ridge profiles with S01 & M01



PART	NO	QTY
	L23C	6
	L05B	6
	D26	2
	S01 M6X12	12
	M01 M6	36
	Z08 M4.2X16	4

Top Assembly

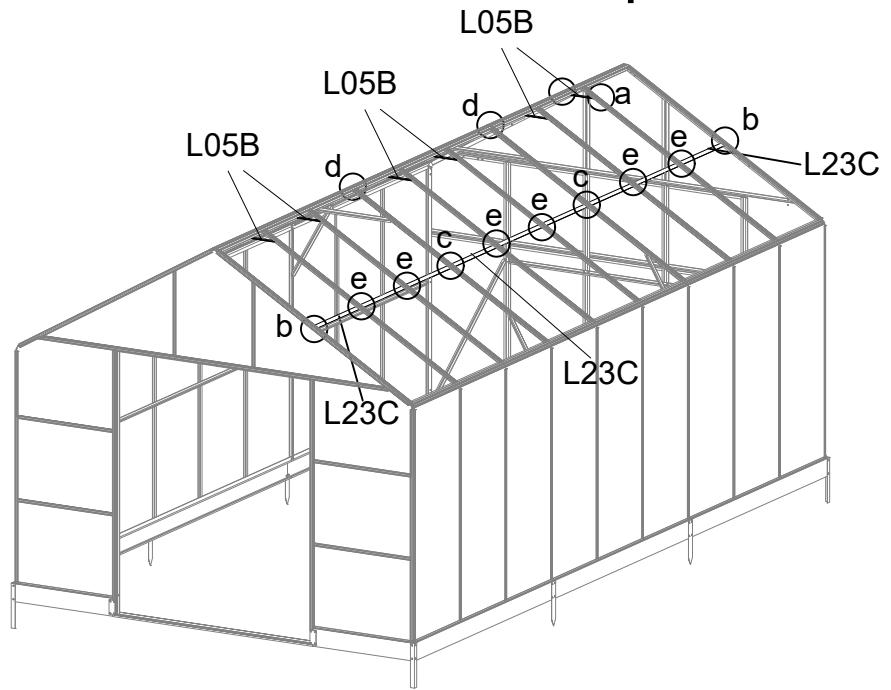

Bolt L05B (d pcs) to L02A & L02B using the S01 bolt placed in the bolt channel earlier.

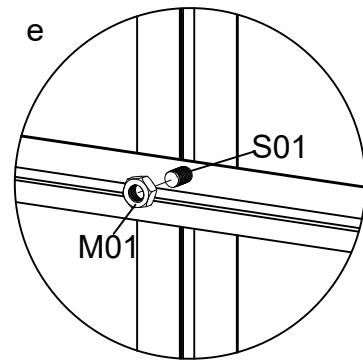
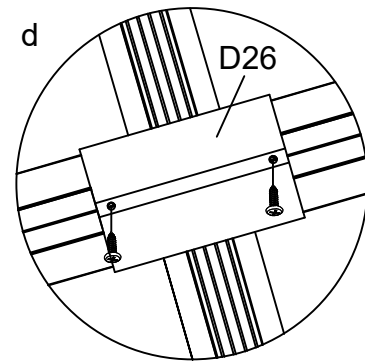
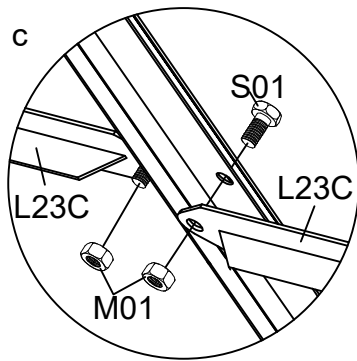
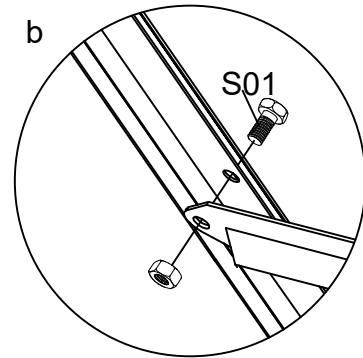
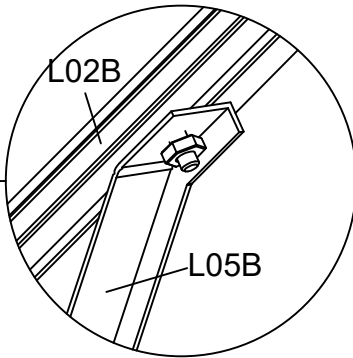
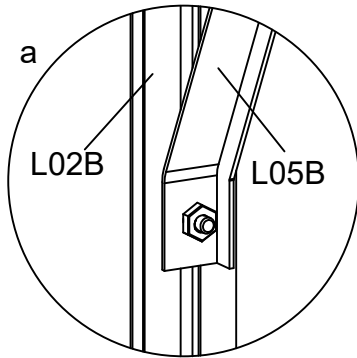





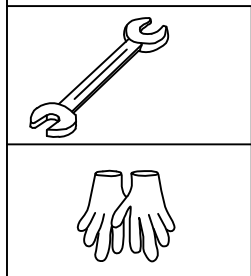

Bolt L23C to L01C/L01D & L03B with S01 & M01.

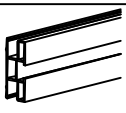
Fix D26 to L06C from outside with self-tapping screws Z08, using a powered screwdriver.

Bolt L23C to L02B using the S01 bolt placed in the bolt channel earlier.



PART	NO	QTY
	L04A	4
	A03	4
	WINDOW	4
	Y7	14
	Y9	8
	S01 M6X12	24
	M01 M6	24

Top Assembly

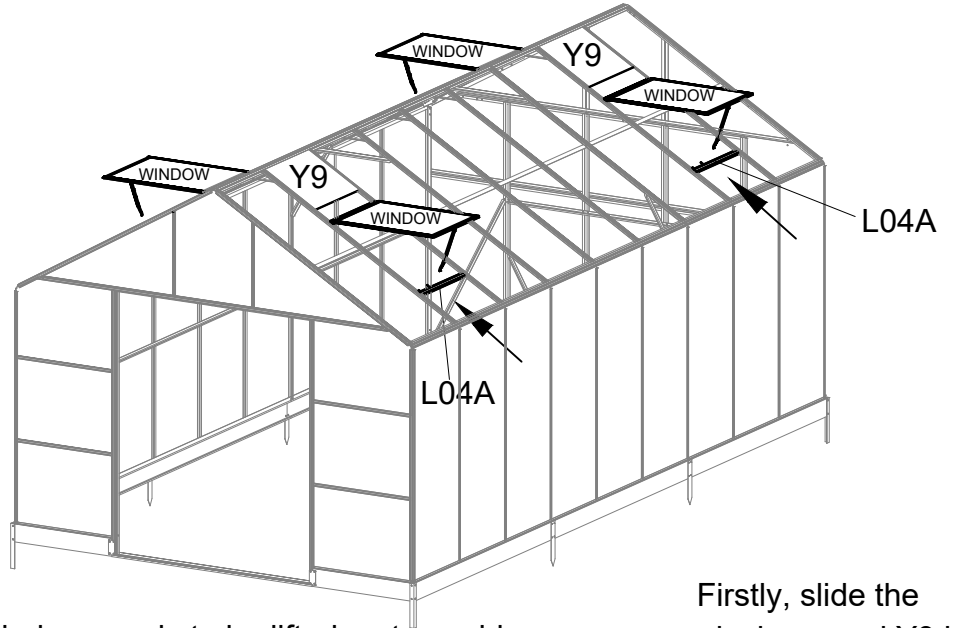

When installing L04A, the window needs to be lifted up to avoid the window not opening after the installation is complete

Firstly, slide the glazing panel Y9 into the channel of L02B/L03B

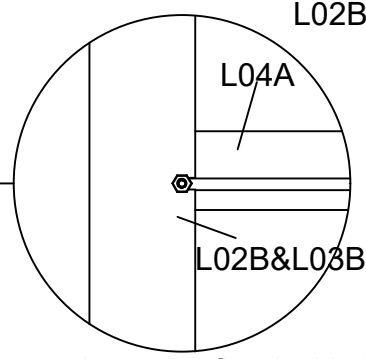
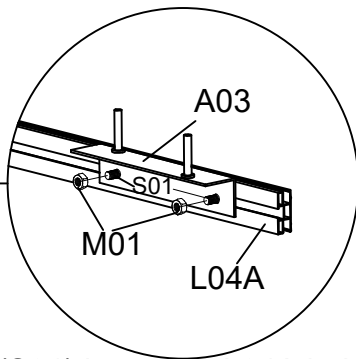
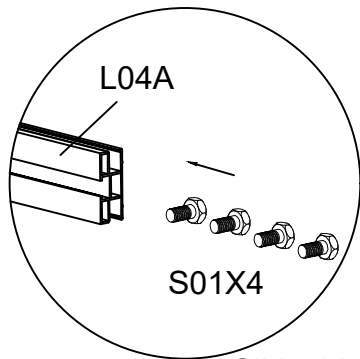

Slide 4 bolts (S01) into each L04A bolt channel. 2 to be fixed with A03, and another 2 to be fixed with L02B/L03B.

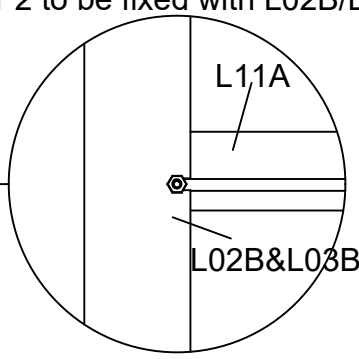
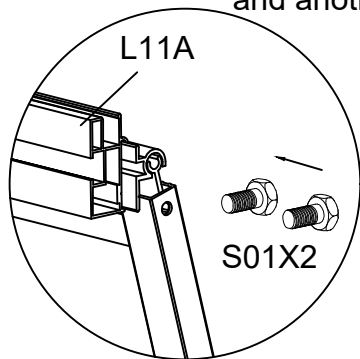



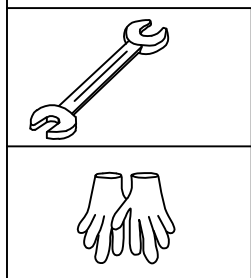
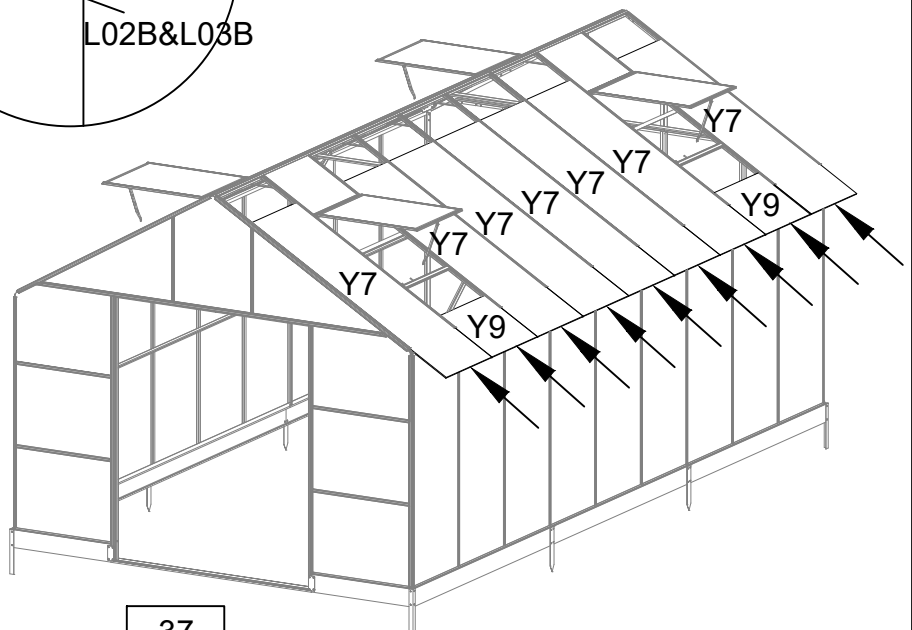

Slide the glazing panels into positions

Slide 2 bolts (S01) into each L11A, and bolt it to L02B/L03B, using the S01 & M01.

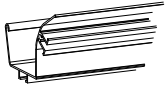

Top Assembly

PART	NO	QTY
	L09C	6
	D25	4
	S01 M6X12	8
	M01 M6	8

After the panels and windows are in position,
put some silicone sealant around to avoid leaking water.

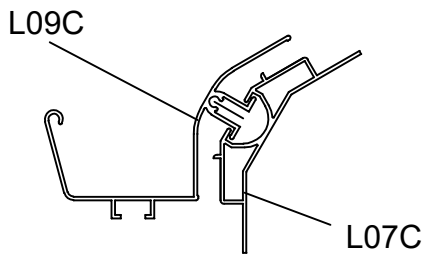
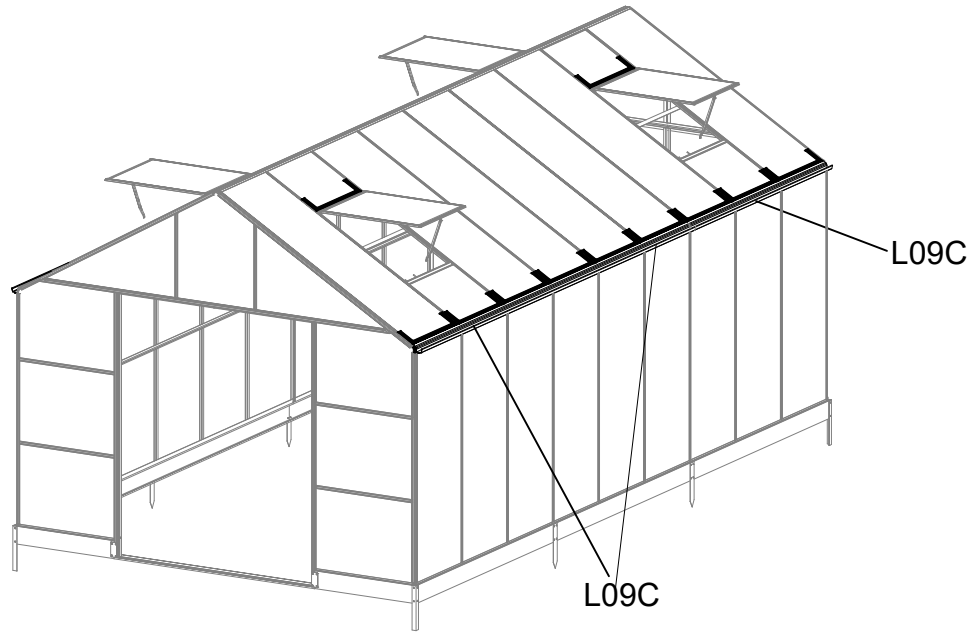



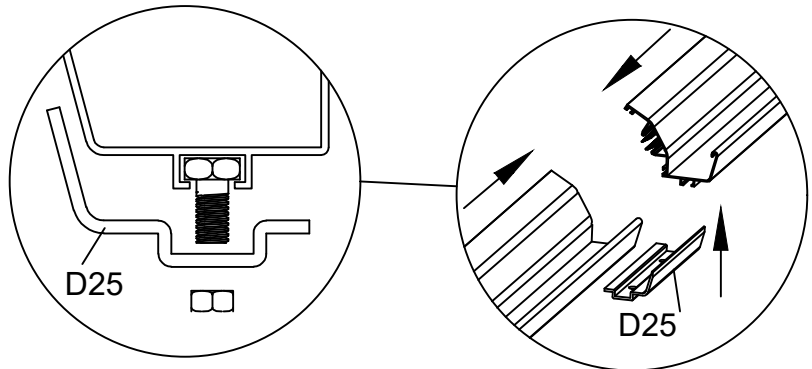

When the panels are completely
inserted, fix gutter profile L09C
Tap it gently into position
with a rubber mallet.

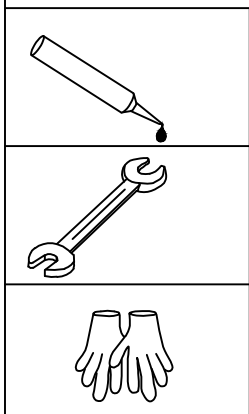

Slide 1*S01 into the bolt channel of both L09C,
fix D25 to L09C using S01 & M01.



Door Assembly

PART	NO	QTY
	D00R-L	1
	D00R-R	1
	A51	4
	Z17 M4.8X16	8
	S27 M5X12	24

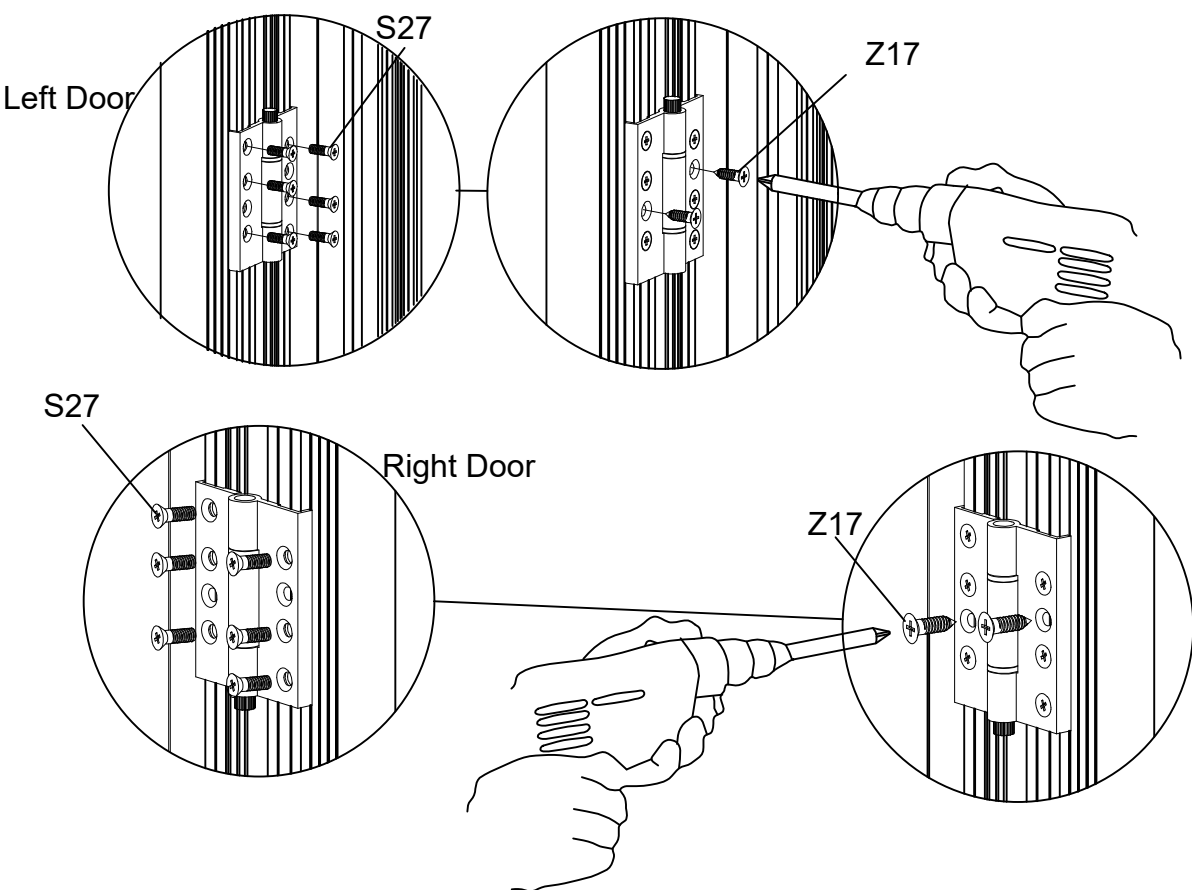
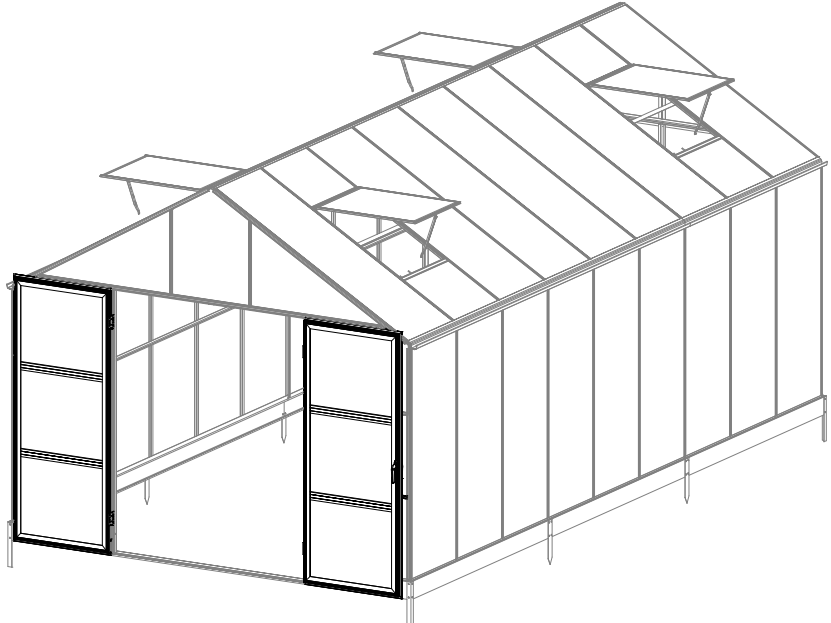

Fix A51(4 PCS) one side on the door profile and the other side to L26A/L26B using S27. Then secure with Z17.

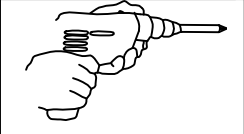

Accessories Assembly

PART	NO	QTY
	J55	2
	J56R	2
	J56L	2
	J94	4
	L25	4
	J93	4
	J165	4
	J166	4
	Z08	4
	M4.2X16	4
	Z02	8
	Ø4X16D	8

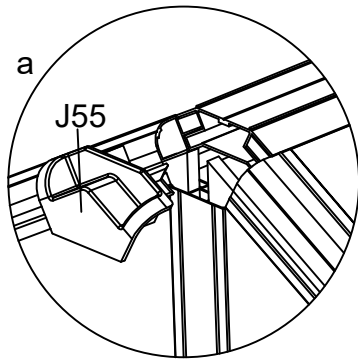
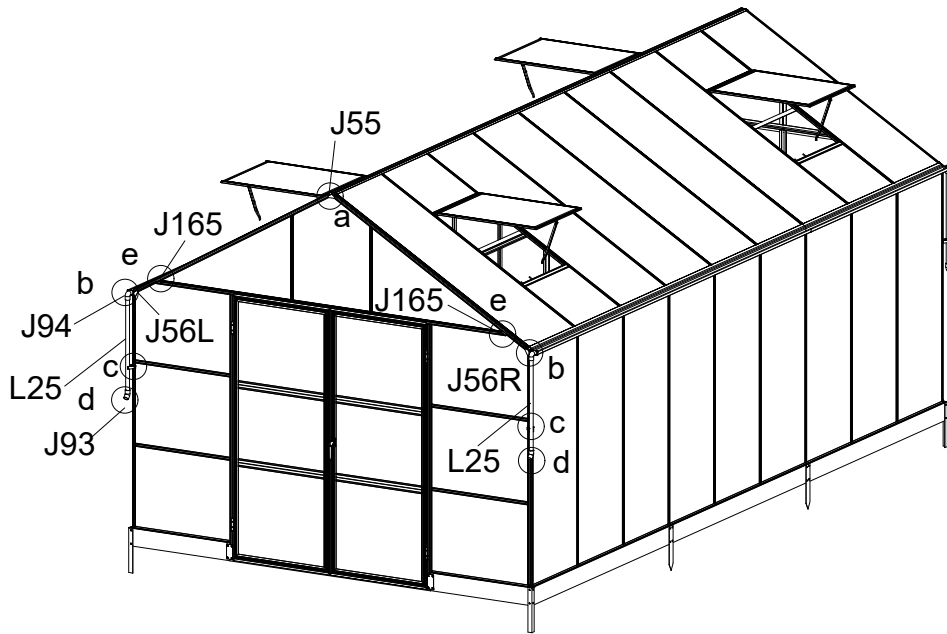

Fix the cover caps J55 into the ridge profile

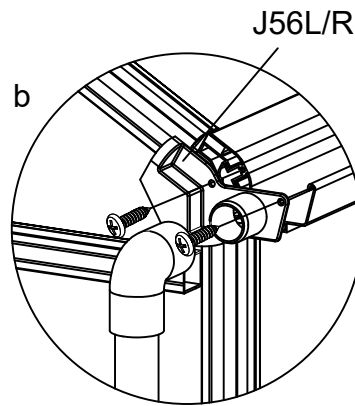

Fix the cover caps (J56L/R) carefully with Z02. Be careful to ensure that the screws are driven in straight and in the correct position (see detail drawings).

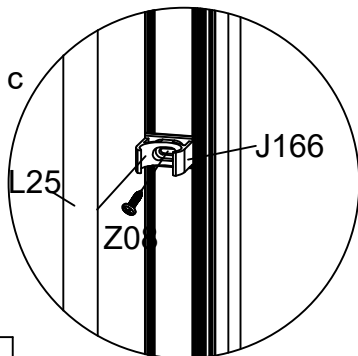

Drill a hole in L01A/L01B, approximately 3mm diameter and 400mm down from the gutter. Fix the J166 downpipe bracket with Z08 screws and then clip the L25 downpipe into the J166 bracket.

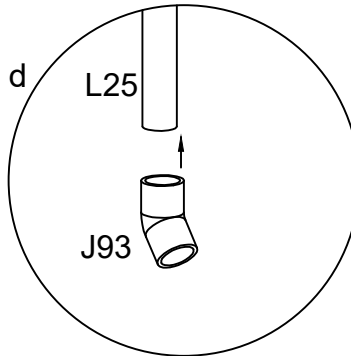

If you wish to eliminate leaks, use glue when fixing the downpipe bends (not provided).

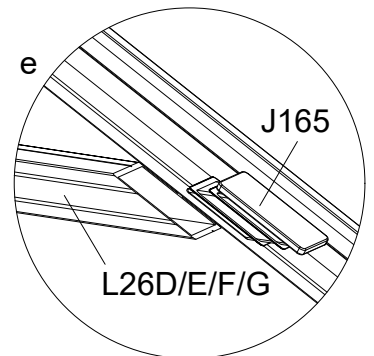

Cover both ends of L26D/E/F/G with cap J165

