

# Assembly Instructions

MODEL:AM956

PRODUCT SIZE(LxWxH): 10X12

PLEASE READ CAREFULLY BEFORE ASSEMBLY

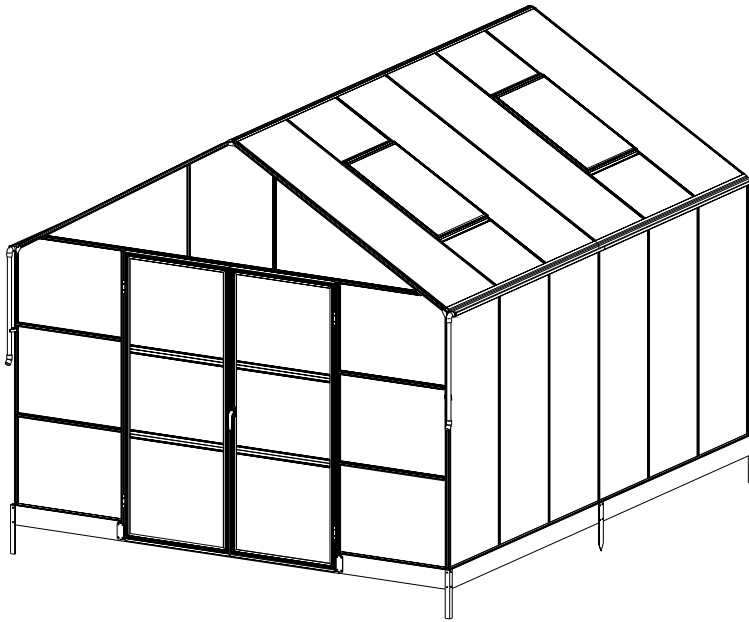

Greenhouse 10x12 FT Assembly Instruction

SKU:

YPG010-1B1A1(BOX 1)

YPG010-1B1A2(BOX 2)

Arrive in 2 separate boxes and may not be part of the same shipment; Please install the product after receiving all the packages.

Email Address:[support@wepatio.com](mailto:support@wepatio.com)

Tel: 901-347-2181

Service Time: 8 am - 5 pm (central time) Monday- Friday.

If no one picks up, please call several more times

2024/10/14

# CONTENTS

1. Assembly Advice .....	Page 1
2. Product Features .....	Page 2
3. Parts List .....	Page 3 -5
4. Door Assembly .....	Page 6 - 11
5. Roof Vent Assembly .....	Page 12 - 14
6. Base Assembly .....	Page 15-17
7. Framework & Glazing Assembly .....	Page 18 - 39

## Assembly and Maintenance Advice

1. For safety purposes, we strongly recommend that this product is assembled by at least two people.
2. Some components have sharp metal edges. Please be careful when handling metal components. Please wear gloves, shoes and safety goggles during assembly.
3. Lay all of the components on a soft carpet or blanket to avoid any scratches or damages.
4. DO NOT climb or stand on the roof. Heavy articles should not be leaned against the greenhouse.
5. Keep the roof and gutter clear of snow, dirt & leaves. Allowing snow to build up on the roof may damage the product.
6. Unlike steel, if the paint finish is scratched this will not harm the aluminium underneath.
7. When your product needs cleaning, use a mild detergent solution and rinse with cold clean water. Do not use acetone, abrasive cleaners or strong detergents to clean the panels.

### Tools Provided:

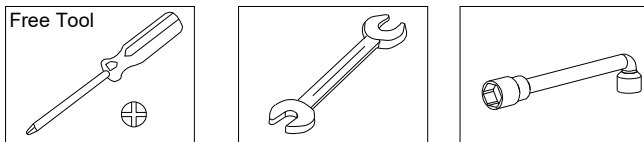

### Tools Required when Assembly (Not Provided)

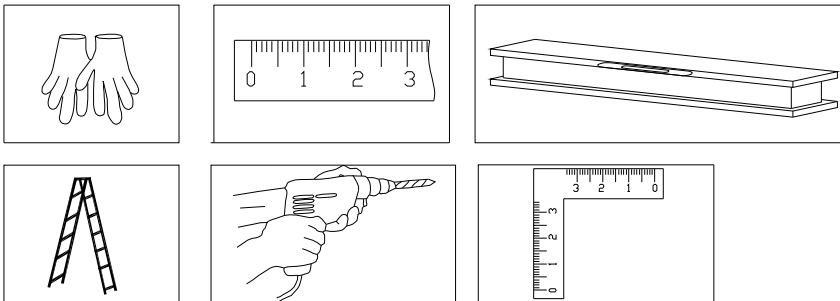

### Assembly at least by two Persons



## Important:

Rubber is not provided if you choose polycarbonate sheet as glazing panel.

## Functions and Features:

1. The strong two part eaves beam includes an integral gutter. Downpipes are also included as standard so you can collect rainwater.

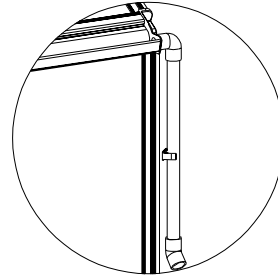

2. Manual window handles are included as standard with the roof vents.

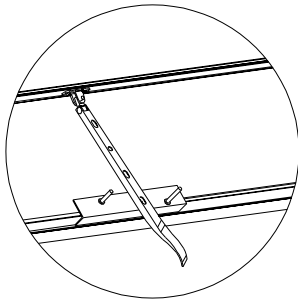



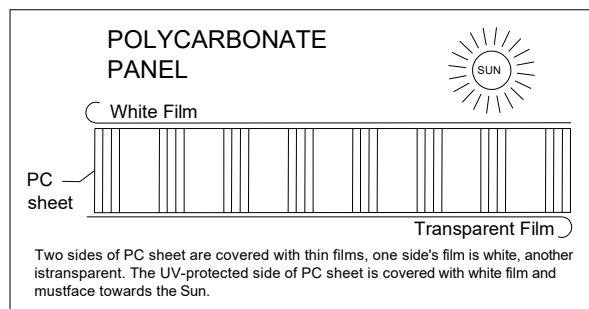

Manual Opener



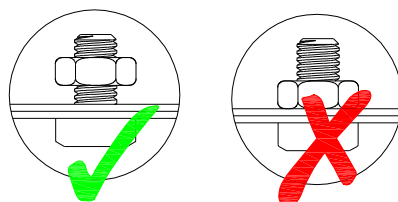

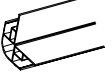
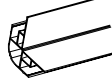
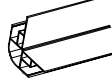
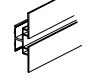
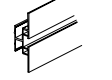
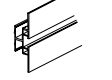
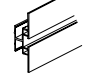
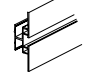
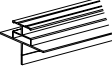
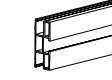

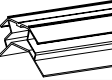
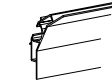
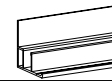
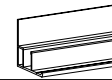
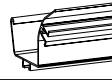
3. Remove approximately 2 inches of film from all sheet edges before installing and remove all film immediately after the construction is completed. Please ensure that the side with the white film faces outwards.



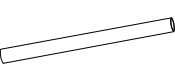

4. This quality greenhouse features self-tapping screws to provide strong joints. As the name suggests, the screws tap their own thread. Driving in self-tapping screws requires more force than conventional screws. A powered screwdriver is therefore recommended.
5. Nuts not to be tightened before the end of assembly! Unless otherwise stated, do not tighten the bolts/nuts/screws until the shed is finally erected!

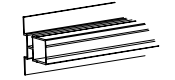





	PART	NO	QTY
1		L01A	1
	1547mm	L01B	1
2		L01E	1
	1547mm	L01F	1
3		L01C	2
	1658mm	L01D	2
4		L02A	8
	1547mm		
5		L02B	8
	1658mm		
6		L02C	2
	578mm	L02D	2
7		L02E	5
	570mm		
8		L02F	4
	717mm		
9		L03A	2
	A:1547 B:1658	L03B	2
10		L04A	4
	570mm		
11		L05B	4
	292mm		
12		L06C	2
	1772mm		
13		L07C	4
	1772mm		
14		L08C	4
	1772mm		
15		L08E	1
	726mm	L08F	1
16		L09C	2
	1773mm		2
17		L10A	2
	590mm		
18		L10B	1
	B:1774 C:1499	L10C	1

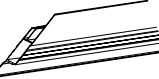
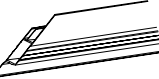



	PART	NO	QTY
19		L23A	4
	888mm		
20		L23C	8
	1753mm	L23D	1
21		L23E	3
	600mm		
22		L25	4
	650mm		
23		L26A	1
	1776mm	L26B	1
24		L26C	4
	1656mm		
25		L26D	1
		L26E	1
		L26F	1
	1334mm	L26G	1

### door









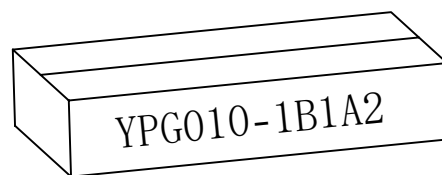





	PART	NO	QTY
23		L16A	2
	1760mm		
24		L17	4
	642mm		
25		L18A	2
	723mm	L18B	2
26		L18C	1
		L18D	1
27	1792mm		

















	PART	NO	QTY
		A2	2
		C2	4
	A2:755 C2:1802 D2:1506	D2	2
		D306	4
		D307	3
		D317	2



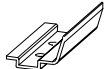





### windowsX4

	PART	NO.	QTY.
28		L11A	4
	584mm		
29		L19	8
	748mm		
		L20	4
	584mm		
		L21	4
	584mm		





PART	NO	QTY
 582X1013mm	Y1	2
 582X1013mm	Y2	2
 754X588mm	Y3	2
 556X735mm	Y4	1
 556X735mm	Y5	1
 1568X588mm	Y6	12
 1682X588mm	Y7	8
 556X735mm	Y8	4
 448X588mm	Y9	8
 726X582mm	Y10	4
 550X662mm	Y11	6
 556X588mm	Y14	1
 556X588mm	Y15	1
 1115X588mm	Y17	5
 556X588mm	Y18	3

PART	NO	QTY
	J55	2
	J56R	2
	J56L	2
	J94	4
	J93	4
	J165	4
	J166	4
	A01	4
	A03	4
	A51	4
	D17	5
	D25	2
	D26	1
	D45	8
	D38	4
	D309	4
	A114	2



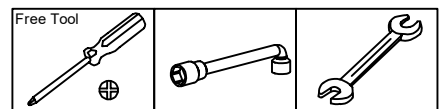

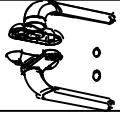



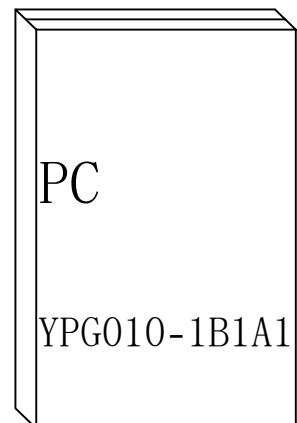





PART	NO	QTY
	S01 M6X12	318+5
	M01 M6	318+5
	Z02 Ø4X16D	32
	Z04 Ø4X8	8
	Z08 M4.2X16	82
	Z17 M4.8X16	8
	D114	16
	S69 M6X60	16

Tools Provided:



PART	NO	QTY
	H152	1
	S76 M4X32	2
	D47	1



PART	NO	QTY
	Y1	2
	Y2	2
	Y3	2
	Y4	1
	Y5	1
	Y6	12
	Y7	8
	Y8	4
	Y9	8
	Y10	4
	Y11	6
	Y14	1
	Y15	1
	Y17	5
	Y18	3

# Panel Exploded View

## Back Wall

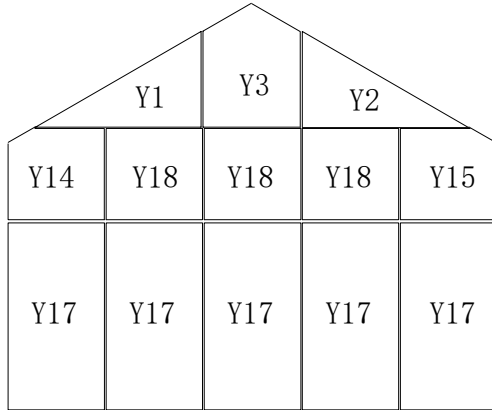



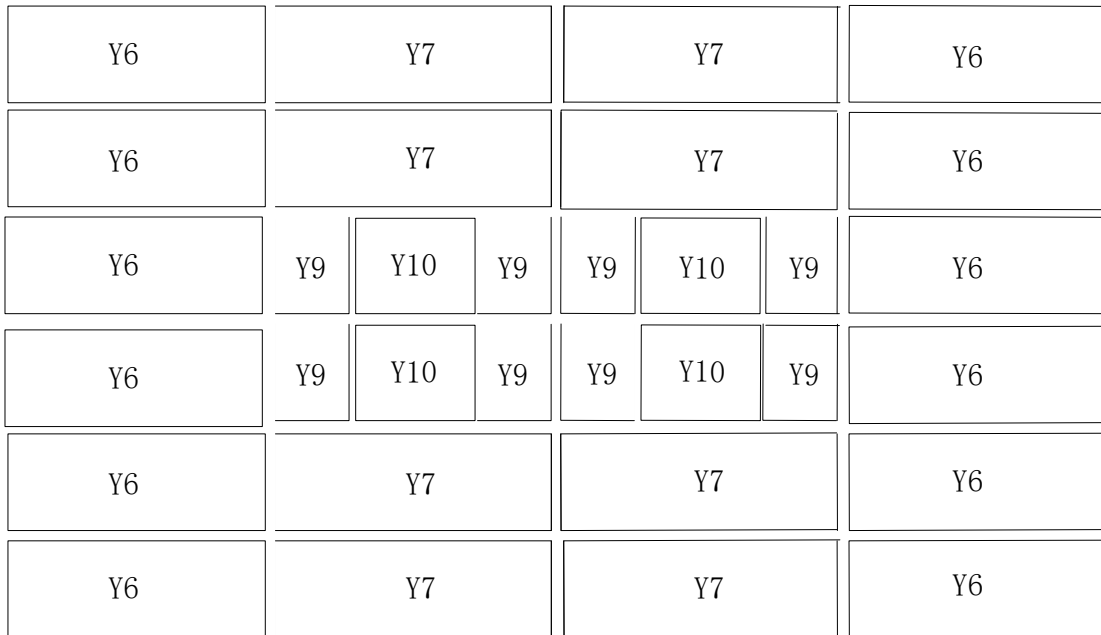



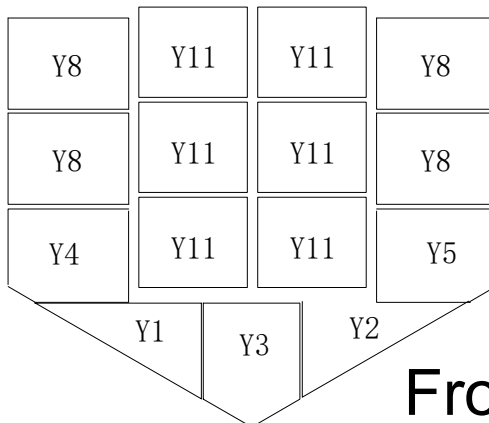

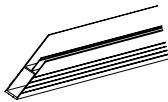

## Side Wall

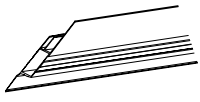

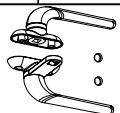
## Side Wall



## Front Wall

PART	NO	QTY
	L16A	2
	L17	4
	L18A	2
	L18B	2
	L18C	1
	L18D	1
	D45	8
	H152	1
	D47	1
	S26	16
	M5X12	
	S76	2
	M4X32	
	Z08	32
	M4.2X16	
	Y11	6





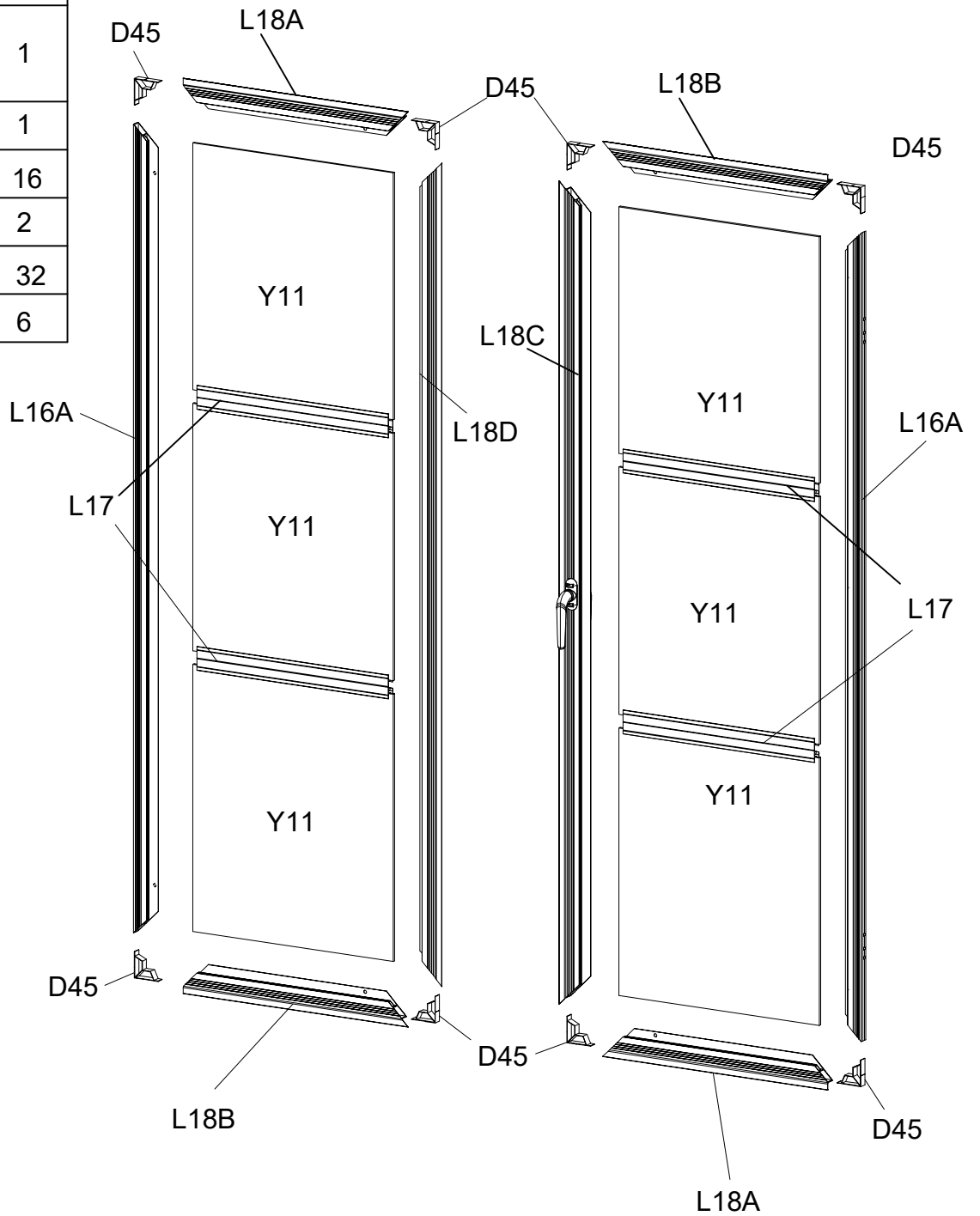

# Exploded View

## Left Door

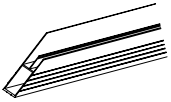
## Right Door

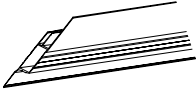



PART	NO	QTY
	L16A	1
	L17	2
	L18A	1
	L18B	1
	L18D	1
	D45	4
	S26	8
	M5X12	
	Z08	16
	M4.2X16	
	Y11	3

# Left Door

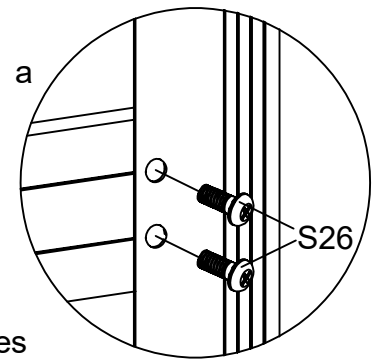
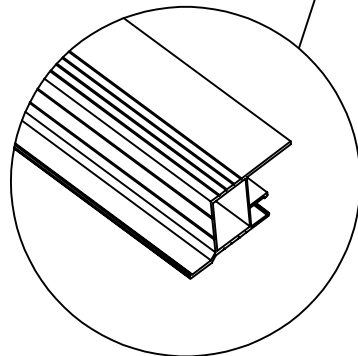
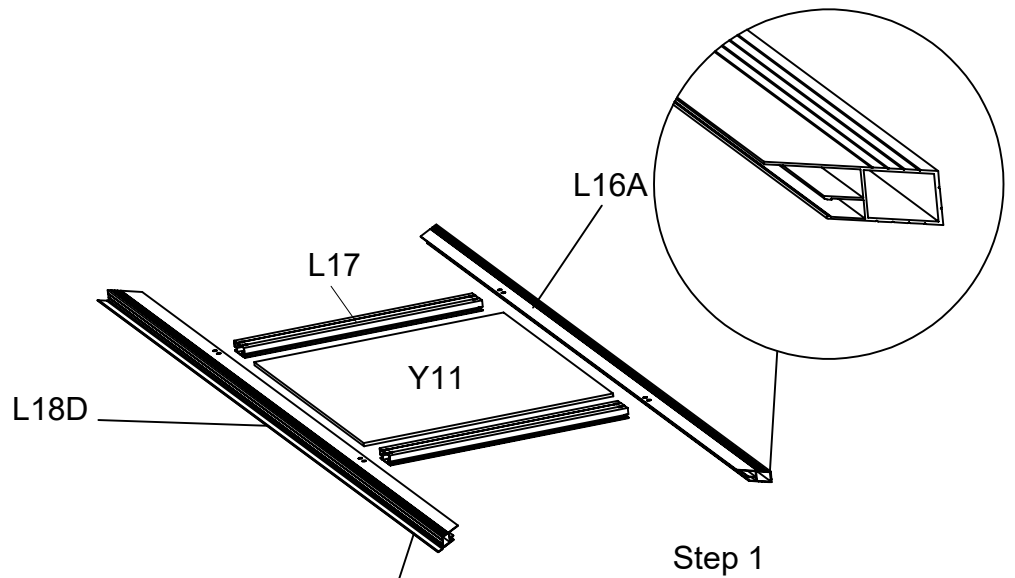

! Attention: Check the direction of the accessories

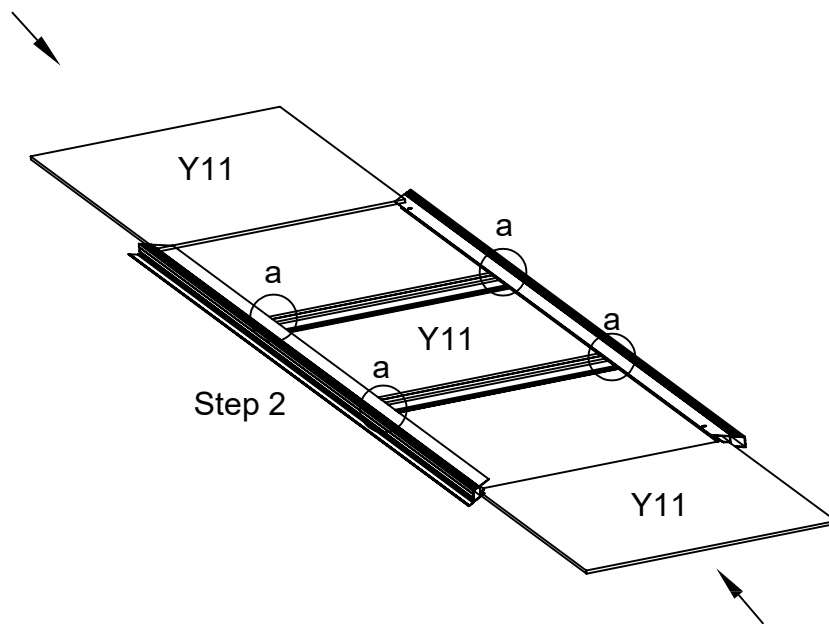

! Attention: Remove the protective films from both sides of each polycarbonate panel, before inserting into aluminum channels. Ensure the milky white film faces towards the Sun.

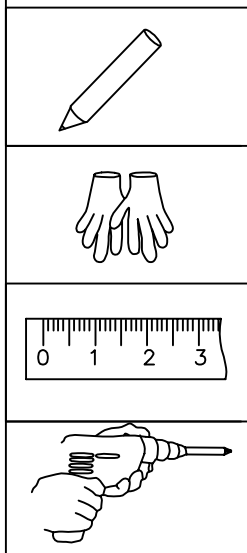

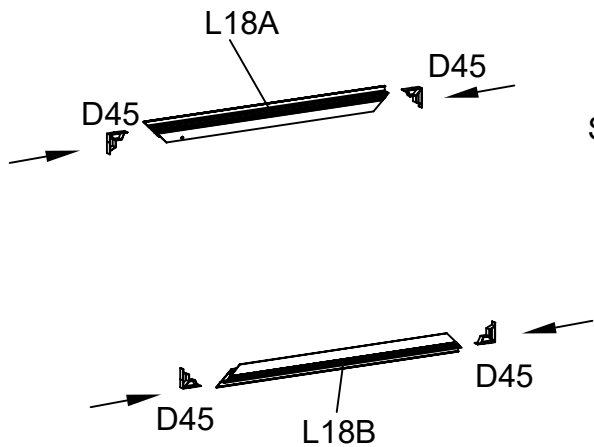

Step 3

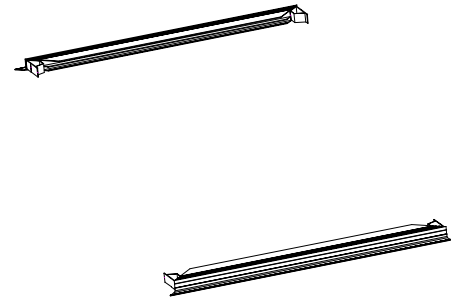

Attention! When installing the D45, you need to use a rubber mallet to lightly tap the snap into.

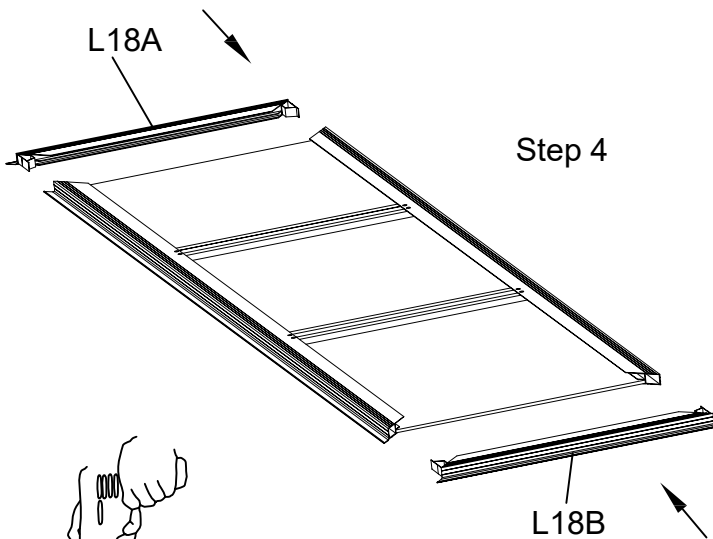

Step 4

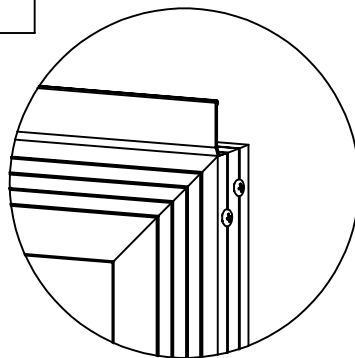
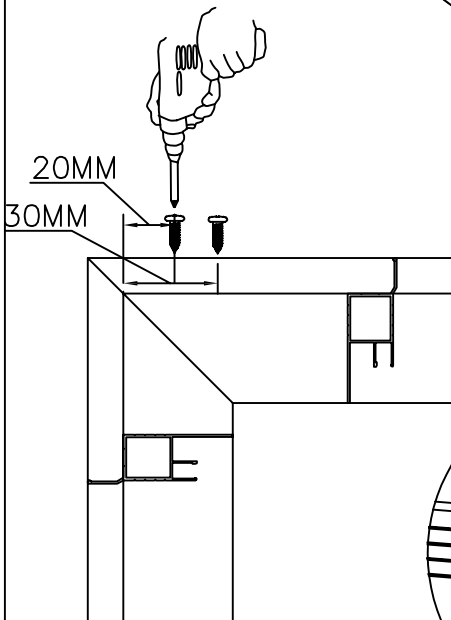
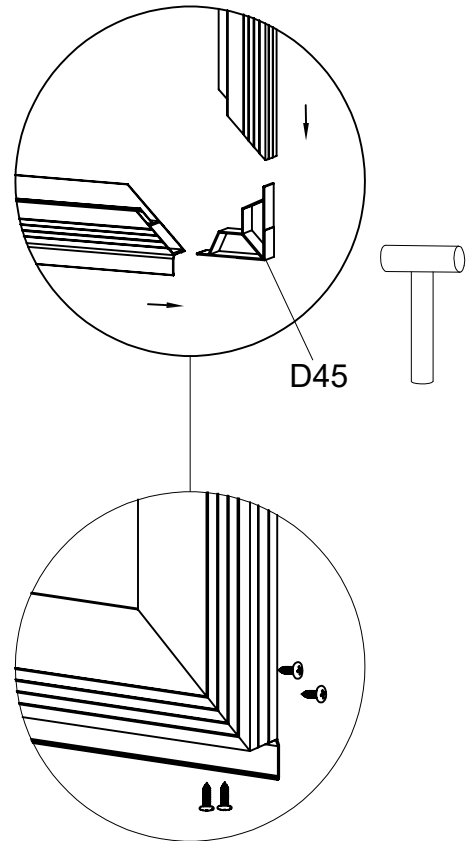

Insert Connector D45 into each end of frame profiles L16B & L18A & L18B & L18D, and then fix them with screws Z08. fixing with screws, and make sure there is no gaps between each profile.

PART	NO	QTY
	L16A	1
	L17	2
	L18A	1
	L18B	1
	L18C	1
	H152	1
	D45	4
	D47	1
	S26 M5X12	8
	S76 M4X32	2
	Z08 M4.2X16	16
	Y11	3

# Right Door

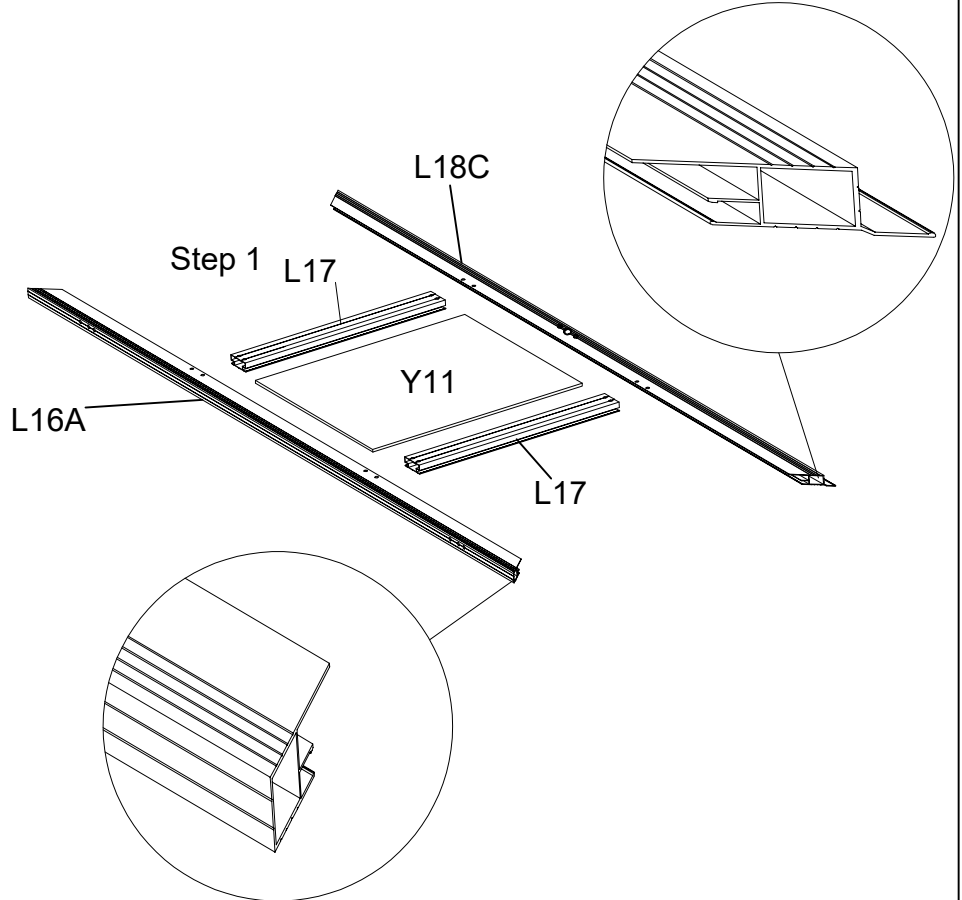

! Attention: Check the direction of the accessories

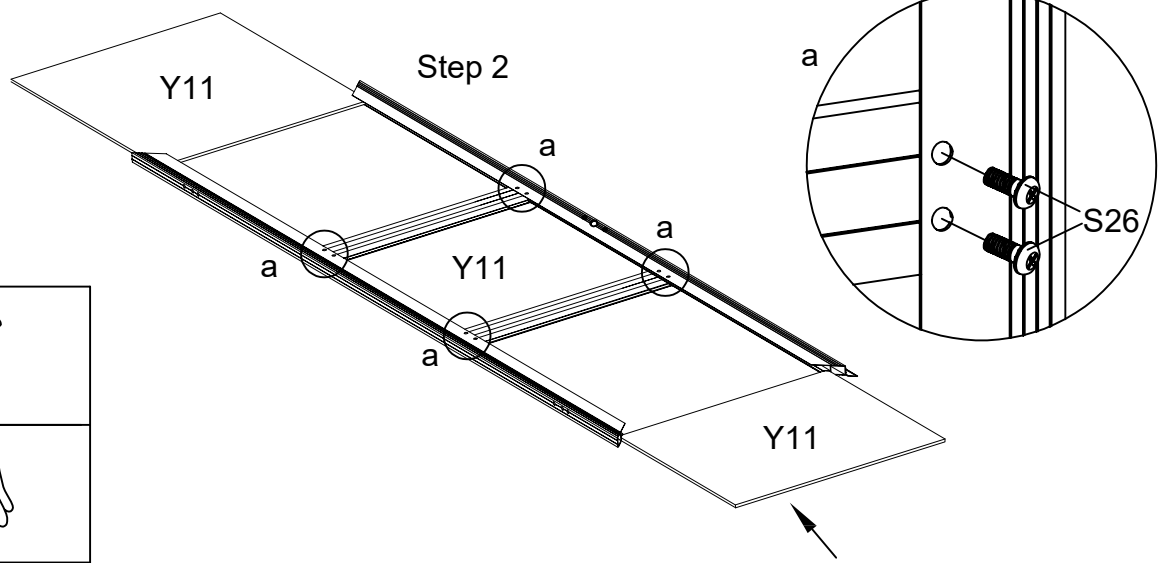

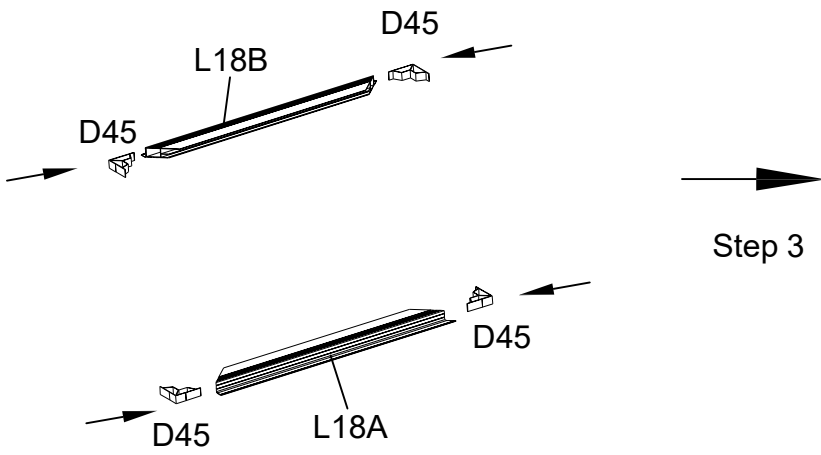

! Attention: Remove the protective films from both sides of each polycarbonate panel, before inserting into aluminum channels. Ensure the milky white film faces towards the Sun.

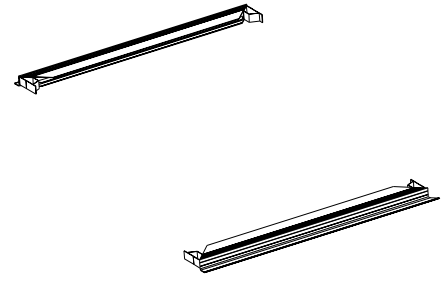

Step 3

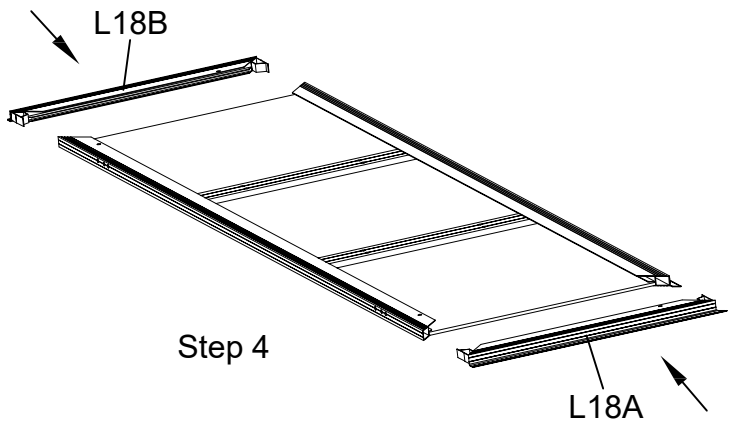

Attention! When installing the D45, you need to use a rubber mallet to lightly tap the snap into.



Step 4

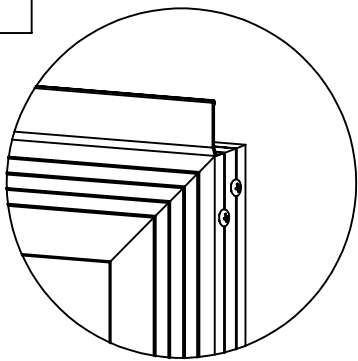
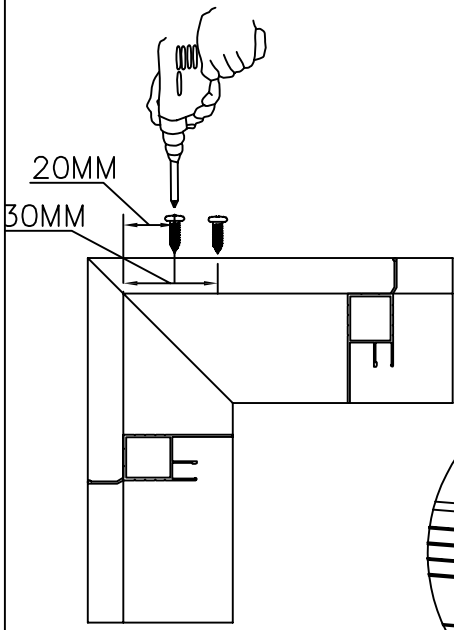
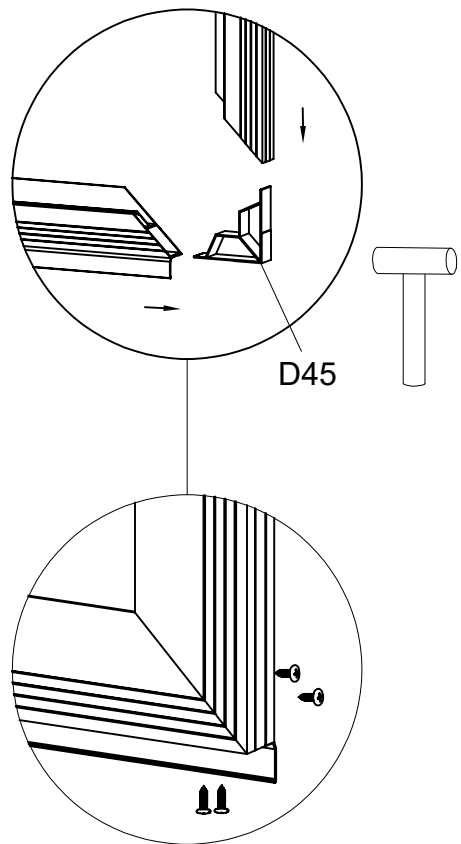



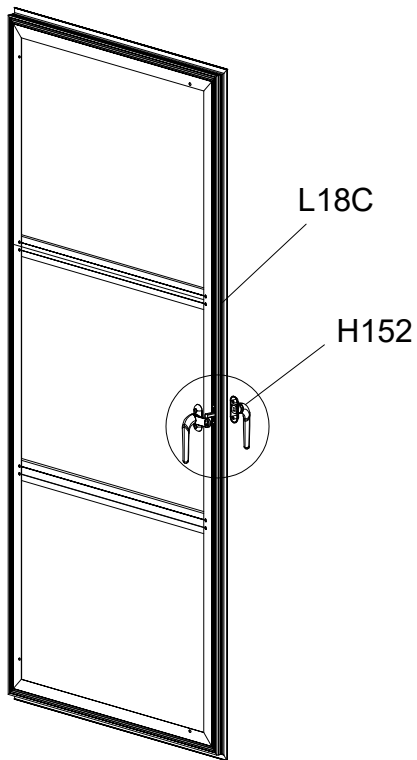



Insert Connector D45 into each end of frame profiles L16B & L18A & L18B & L18D, and then fix them with screws Z08. fixing with screws, and make sure there is no gaps between each profile.

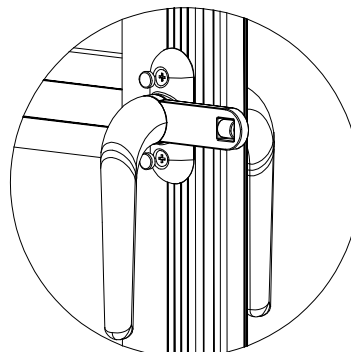
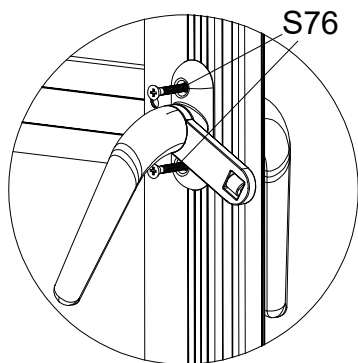
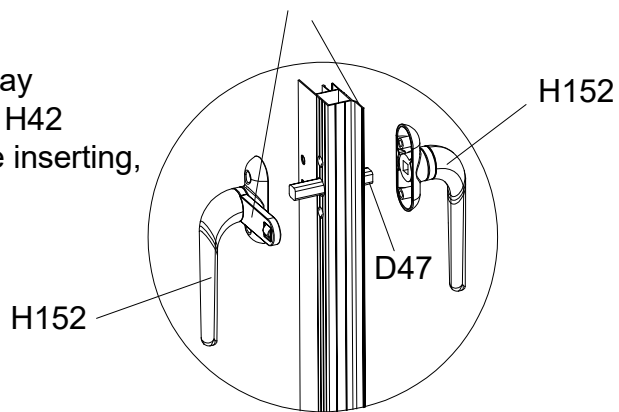

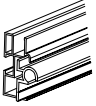
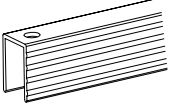
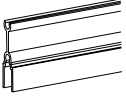
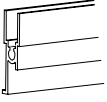
Pay attention to the installation direction

Install H152 after installing the door, when installing, pay attention to the H152 long end toward the door edge, H42 square hole aligned with the square column D47 while inserting, placed in the right position and then fixed with S76, and finally installed on the decorative cover







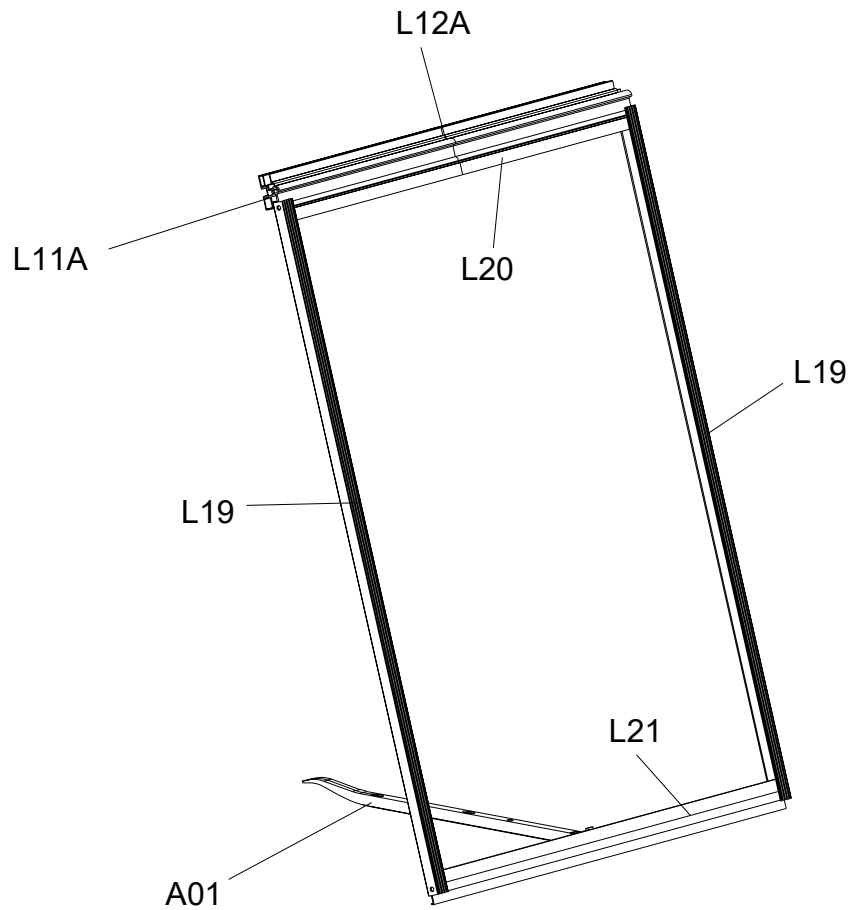

PART	NO.	QTY.
	L11A	4
	L19	8
	L20	4
	L21	4
	Y10	4
	A01	4
	Z02 Ø4X16D	24
	Z04 Ø4X8	8
	Z08 M4.2X16	8

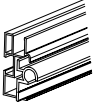
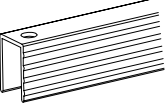
# Exploded View

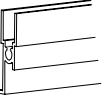
## Window X 4



PART	NO.	QTY.
	L11A	1
	L19	2
	L20	1
	L21	1

Part	NO.	QTY.
	Y10	1
	A01	1
	Z02 Ø4X16D	6
	Z04 Ø4X8	2

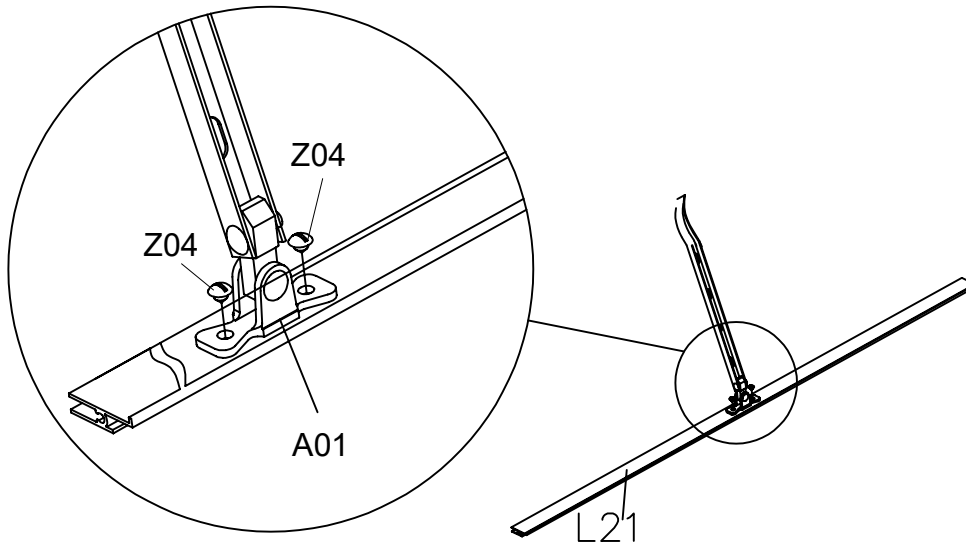

Step 1

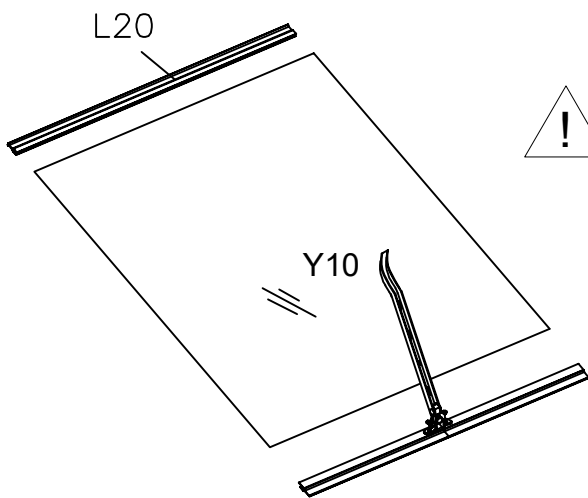

Step 2





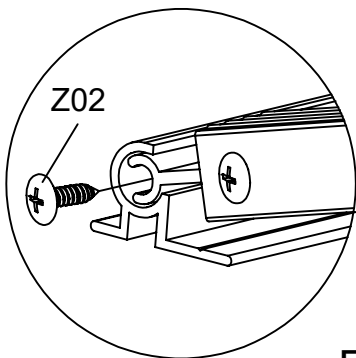
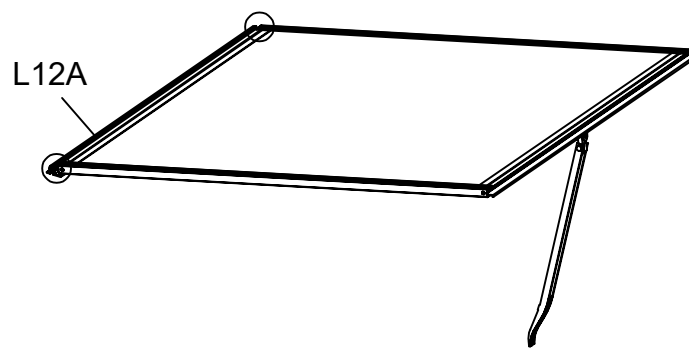
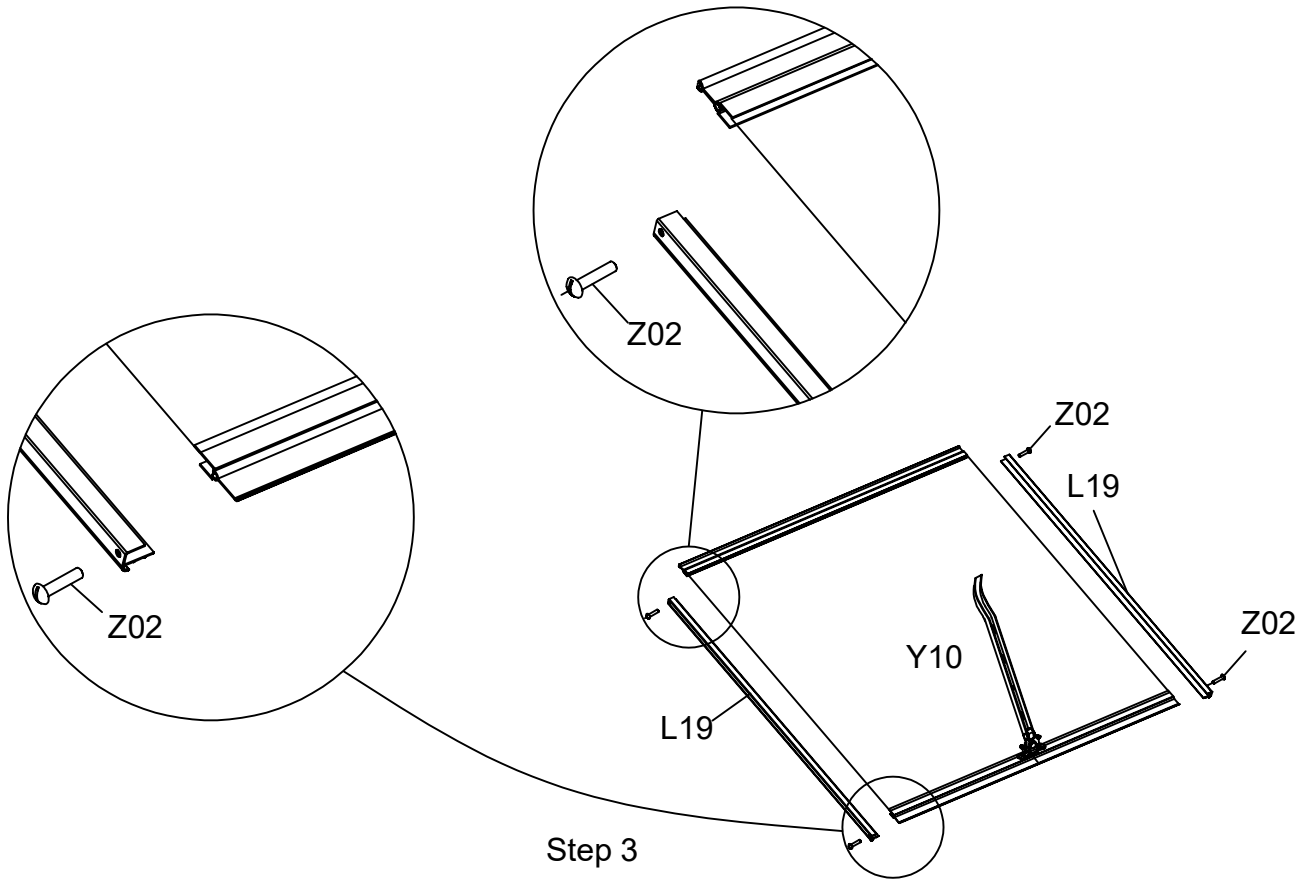



**! Attention:** Remove the protective films from both sides of each polycarbonate panel, before inserting into aluminum channels. Ensure the milky white film faces towards the Sun.



Four windows are standard



PART	NO	QTY
	A2	2
	C2	4
	D2	2
	D306	4
	D307	3
	S01 M6X12	28
	M01 M6	28

# Base Assembly

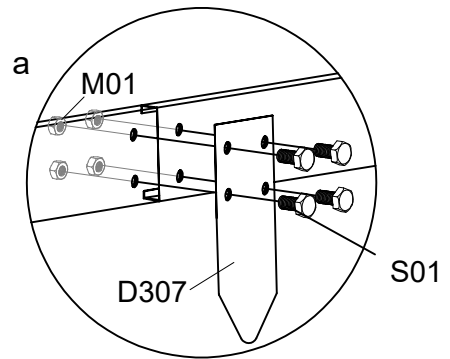
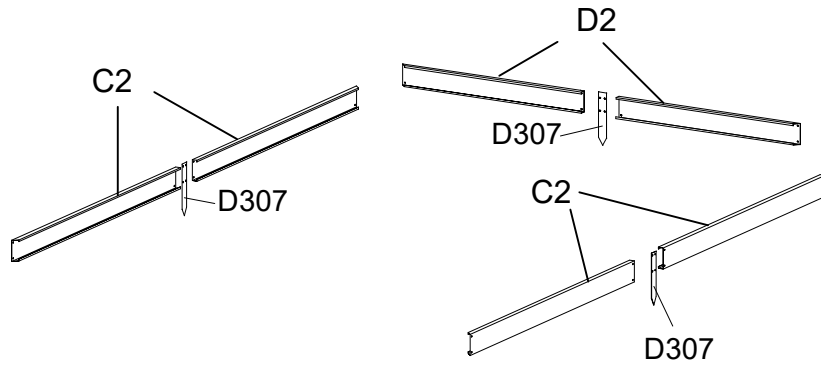

Attention! D306 and D307 must be inserted into the soil or installed in reverse!

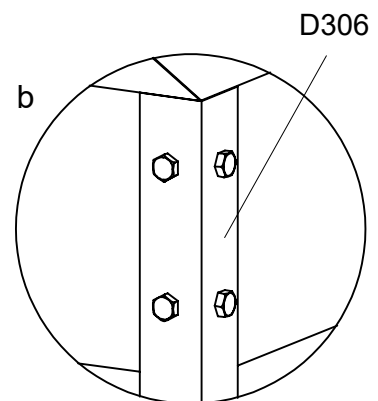
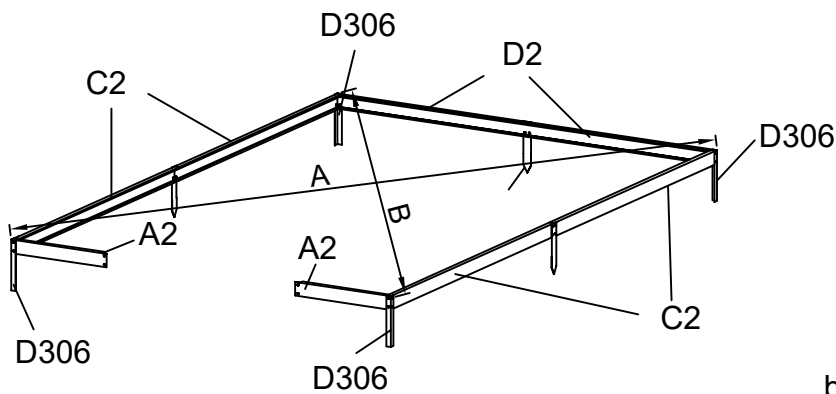

Ⓐ = Ⓑ



Fix the base before assembly the greenhouse. This is the way to fix the base.

# Base Assembly

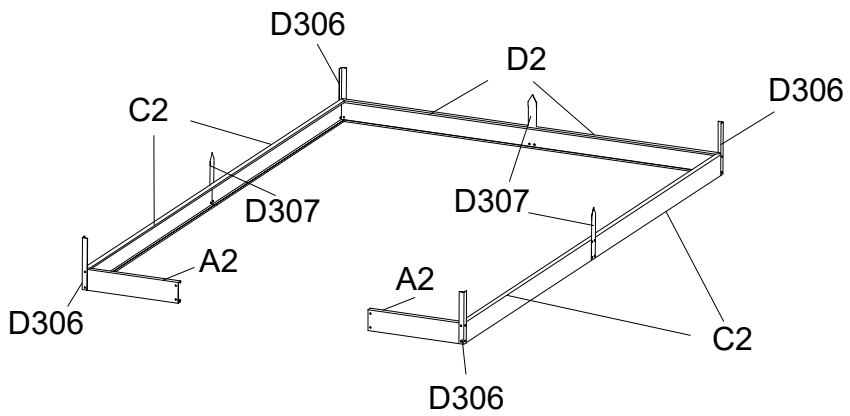

! Attention: Turn over the steel plinths D306 & D307 to complete the base installation as shown below, when the greenhouse is NOT inserted and secured into the soft soil.







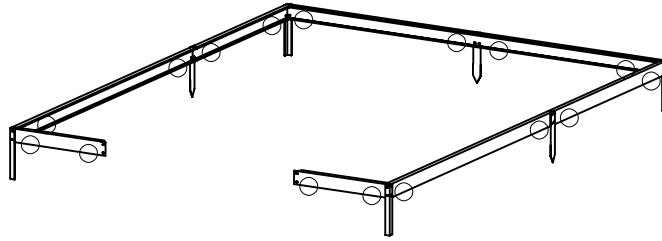

PART	NO	QTY
	D114	16
	S69 M6X60	16

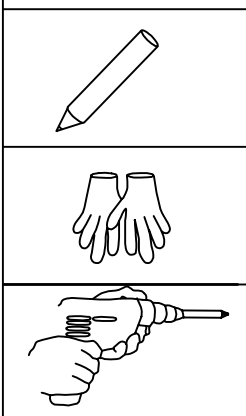
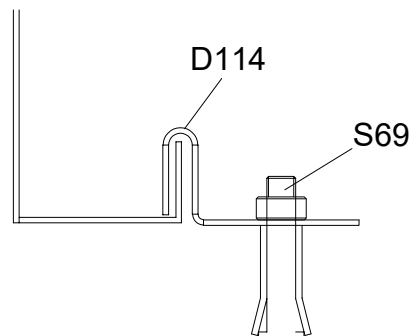
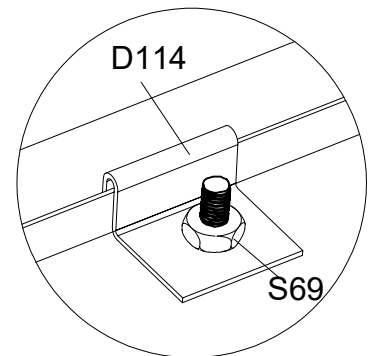
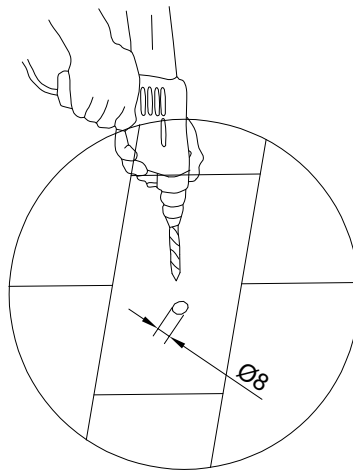
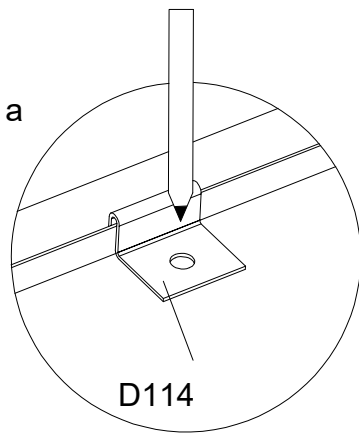
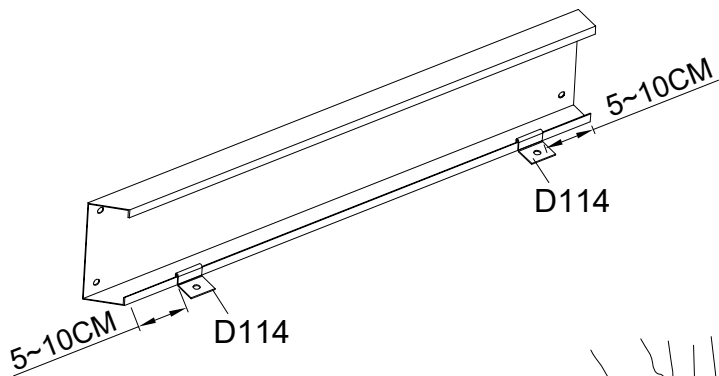
# Base Assembly

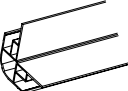

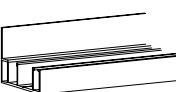
1. Fix the base anchor clip D114 onto each base section with a distance of 5~10CM from each end.
2. Mark the middle of the D114 hole to drill the  $\varnothing 8$  hole, then use S69 to fix the D114 to the ground



PART	NO	QTY
	L01E	1
	L01F	1
	L08C	2
	L10A	2
	L10B	1
	S01	4
	M6X12	
	M01	4
	M6	
	Z08	8
	M4.2X16	

# Wall Assembly

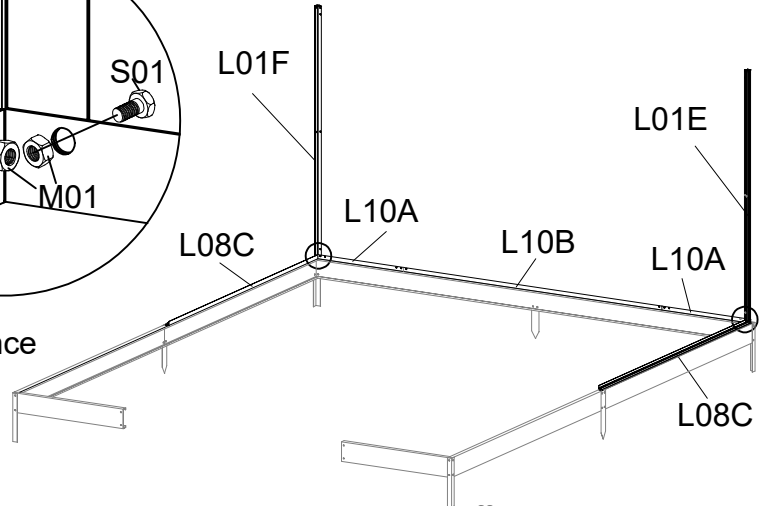
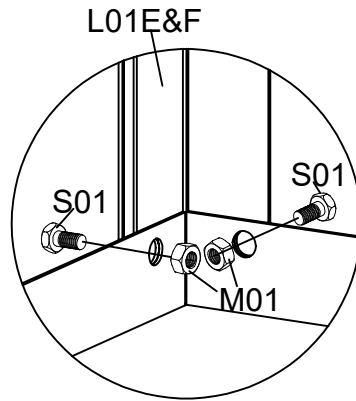

Different distance

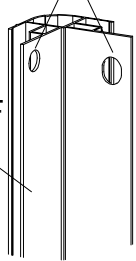

Attention! L01E, L01F holes with different distances should be installed facing upwards.

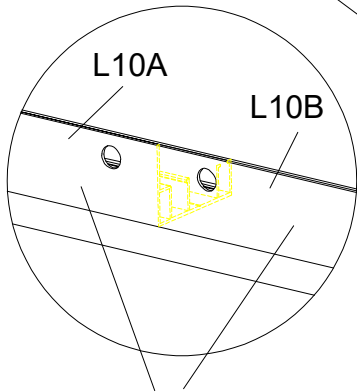

Line up from inside

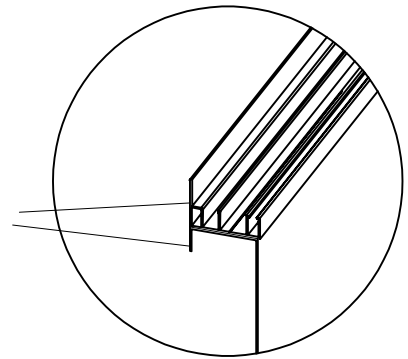

Make sure they line up from inside with the base plinth before fixing them with Z08

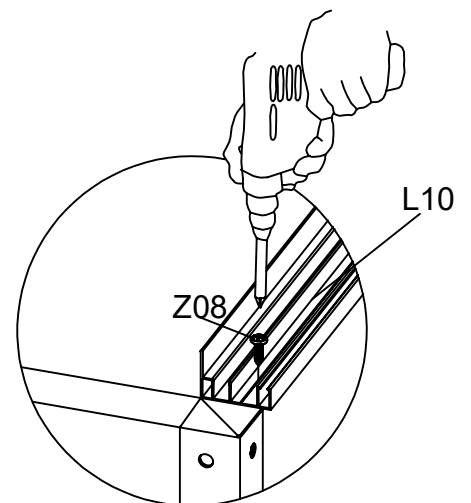
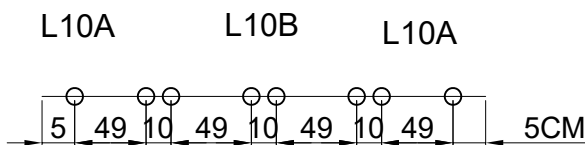
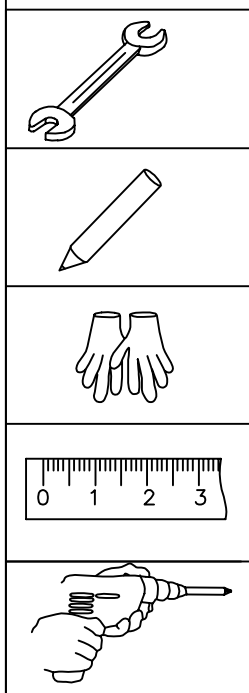

1. Place L10A, L10B, L01E, L01F & L08C on the base plinth (B2 & C2), then fix them together using S01 & M01 as shown. Make sure they line up from inside of the base plinth.
2. Use a powered screwdriver to fix the self-tapping screws (Z08) through the cills (L10A, L10B & L08C) and base plinth (B2, C2 and A2). The screws should be evenly spaced to ensure a neat appearance. The recommended spacing of the screws is 490mm. You can mark the painted surfaces with a pencil.

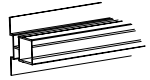

# Wall Assembly

PART	NO	QTY
	L23A	2
	L23D	1
	L26C	4
	S01 M6X12	18
	M01 M6	18

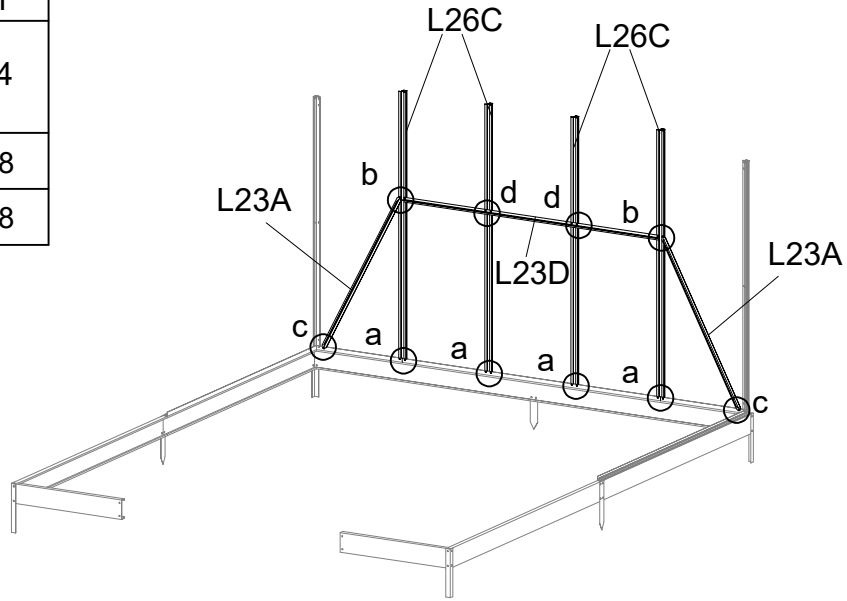



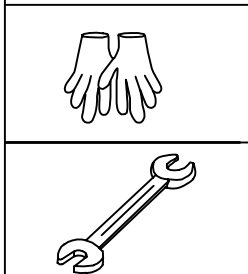
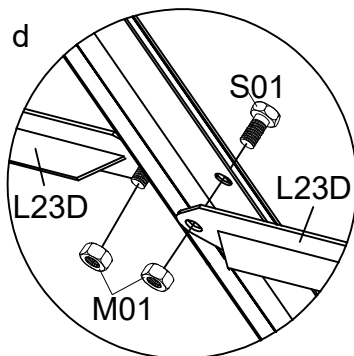
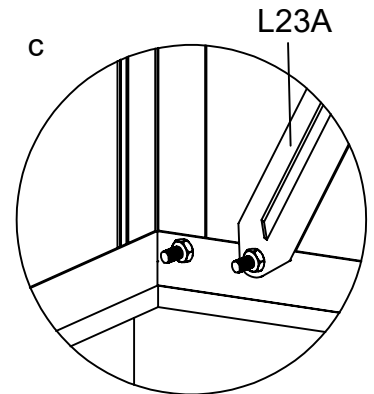
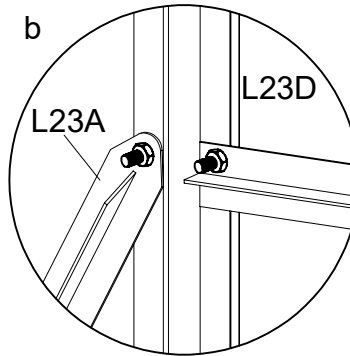
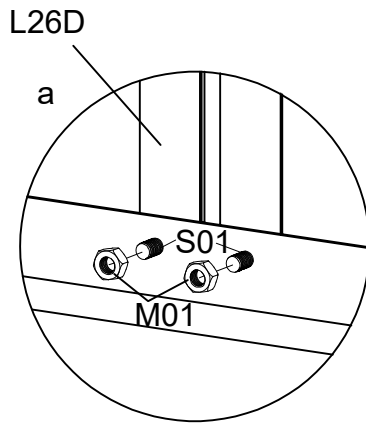

Fix L26D onto L10B, using S01 & M01.

Fix L23A&L23D to L01E, L01F & L26C,using S01 & M01

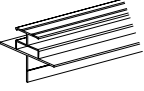
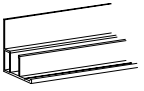

# Wall Assembly

PART	NO	QTY
	L03A	2
	L08C	2
	S01 M6X12	4
	M01 M6	4
	Z08 M4.2X16	12

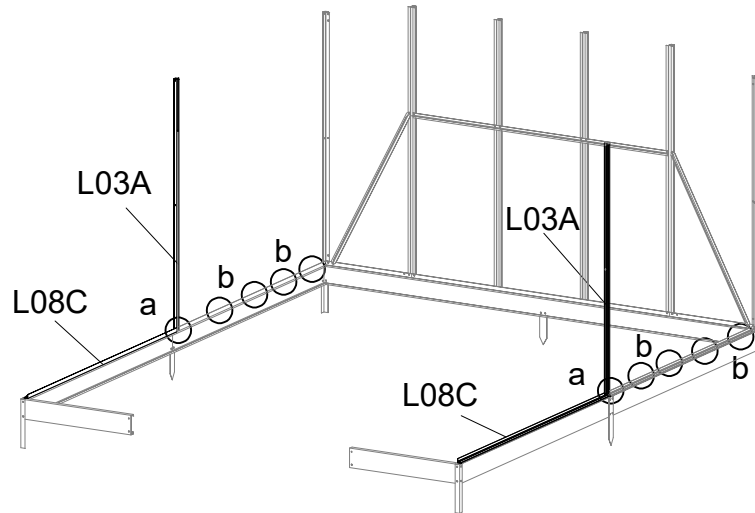

1. Place L08C on the base plinth and fix L03A onto L08C, using S01 & M01.
2. Use a powered screwdriver to fix the self-tapping screws (Z08) through the cills (L08C) and base plinth (C2). The screws should be evenly spaced to ensure a neat appearance. The recommended spacing of the screws is 490mm. You can mark the painted surfaces with a pencil.

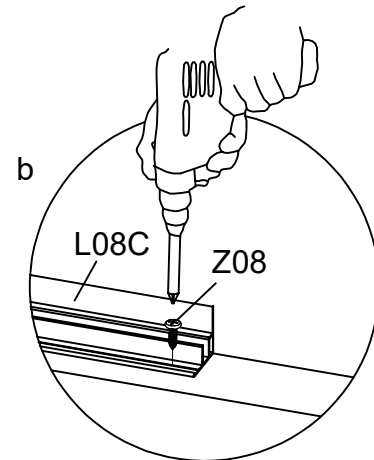
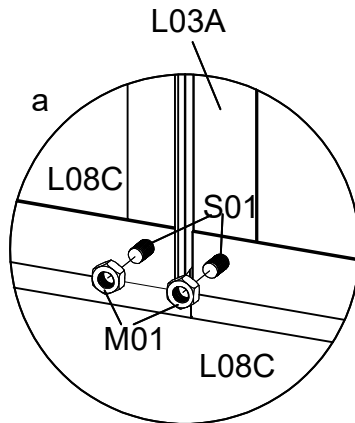
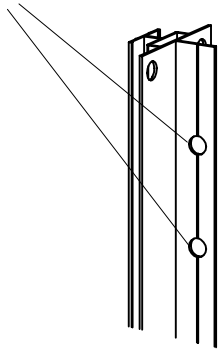

**Attention!** : Install the L03A with the side with the hole facing up!

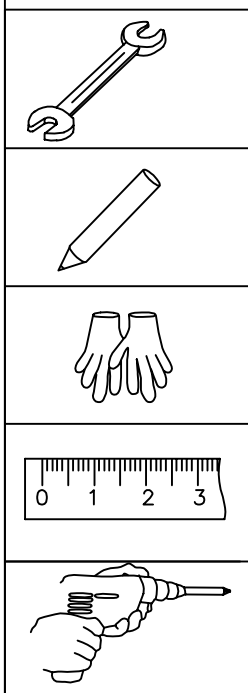
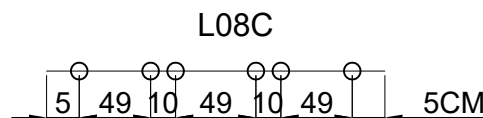

Z08 distances reference

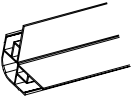
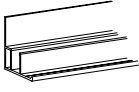

# Wall Assembly

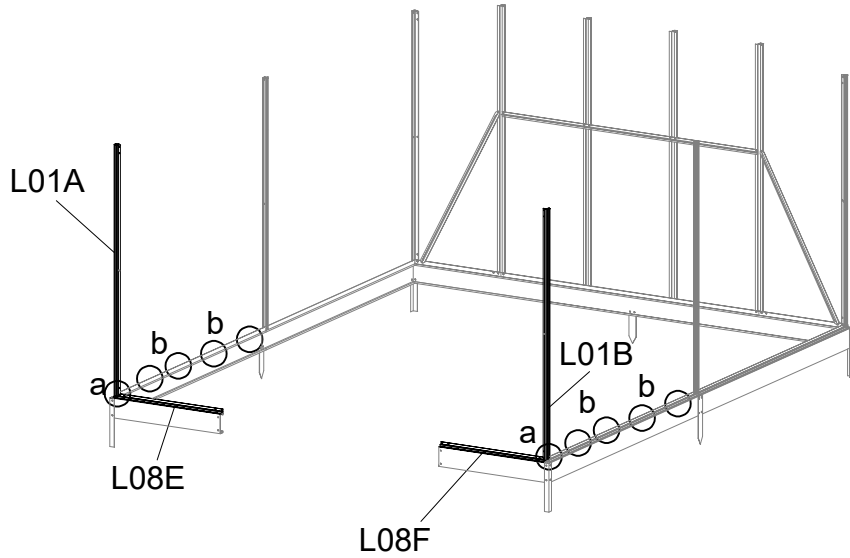

PART	NO	QTY
	L01A	1
	L01B	1
	L08E	1
	L08F	1
	S01 M6X12	4
	M01 M6	4
	Z08 M4.2X16	16

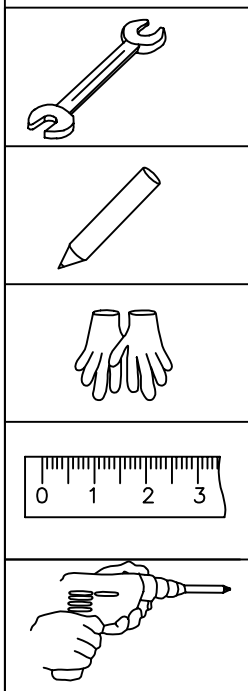
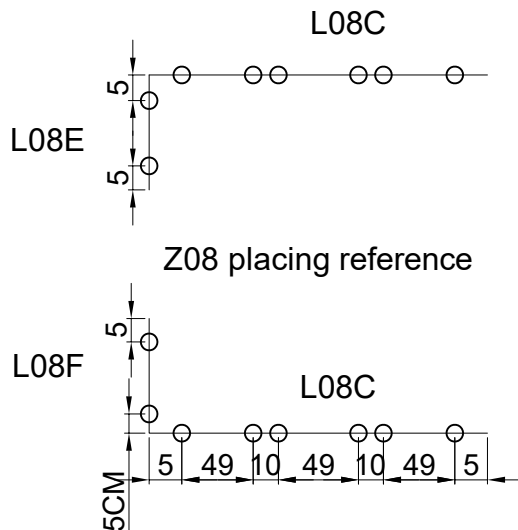
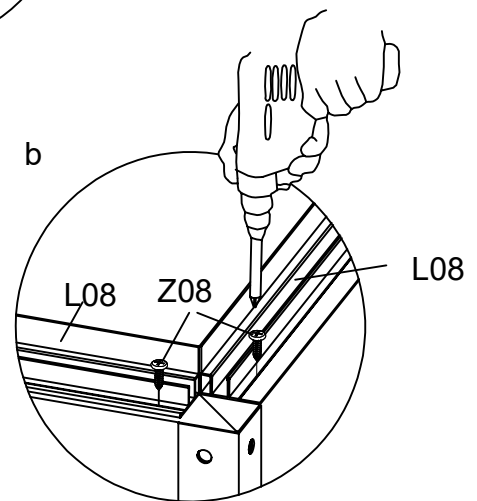
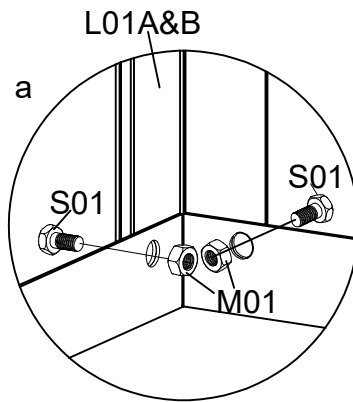

1. Place L08E & L08F on the base plinth and fix L01A & L01B onto L08C & L08E/L08F, using S01 & M01.
2. Use a powered screwdriver to fix the self-tapping screws (Z08) through the cills (L08C, L08E & L08F) and base plinth (A2 & C2). The screws should be evenly spaced to ensure a neat appearance. The recommended spacing of the screws is 490mm. You can mark the painted surfaces with a pencil.



# Wall Assembly

PART	NO	QTY
	L23C	4
	S01 M6X12	8
	M01 M6	8

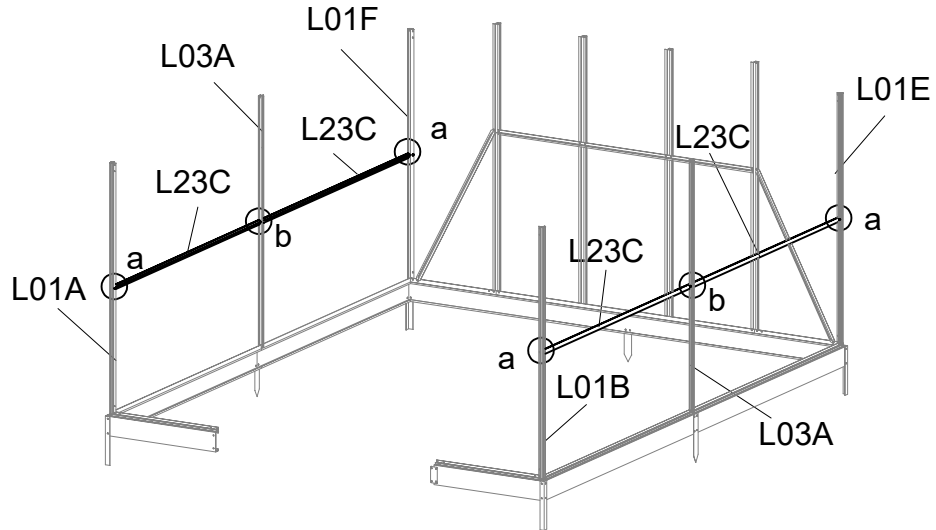



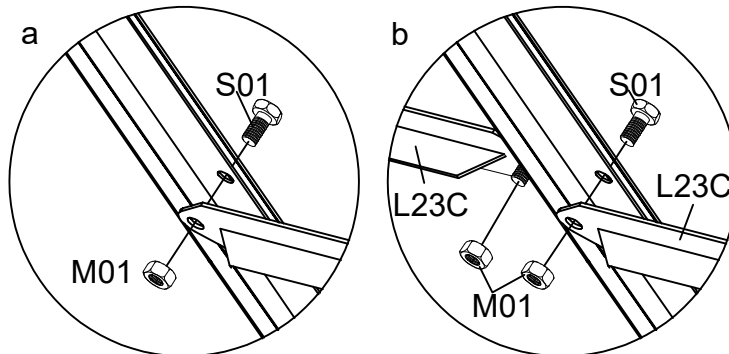

Fix L23C \* 4PCS onto L01A, L01B, L03A, L01E & L01F, using S01 & M01



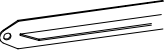
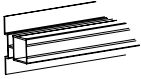

# Wall Assembly

PART	NO	QTY
	L10C	1
	L23A	2
	L26A	1
	L26B	1
	D317	2
	S01 M6X12	12
	M01 M6	12
	S26 M6X12	4

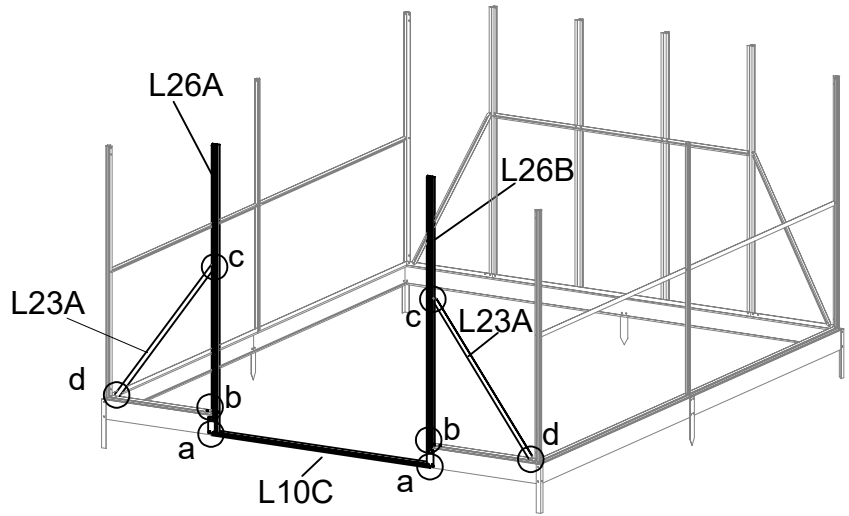

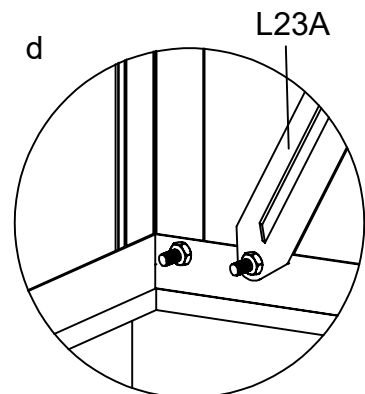
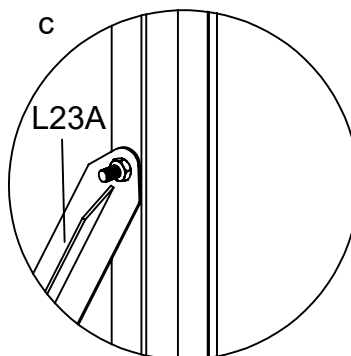
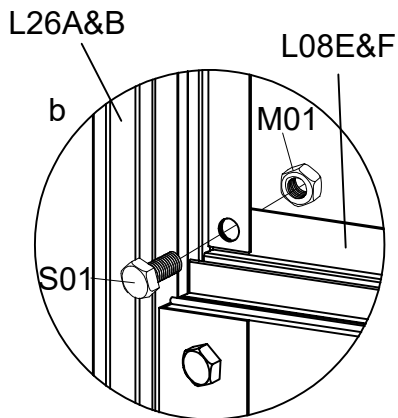
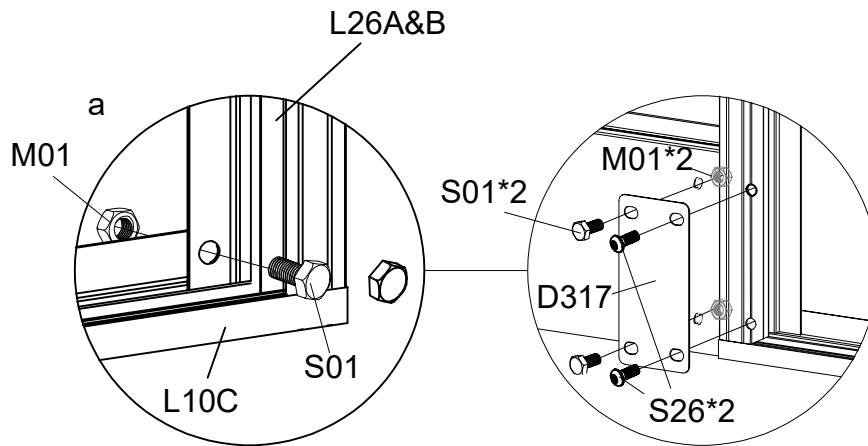

Fix L26A onto L08E,  
L26B onto L08F using S01 & M01

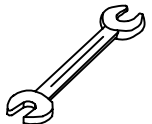

Fix L23A \* 2PCS onto L01A & L26A  
/L01B & L26B, using S01 & M01.



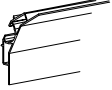

# Wall Assembly

PART	NO	QTY
	L07C	4
	S01 M6X12	8
	M01 M6	8

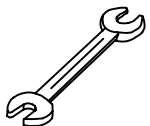
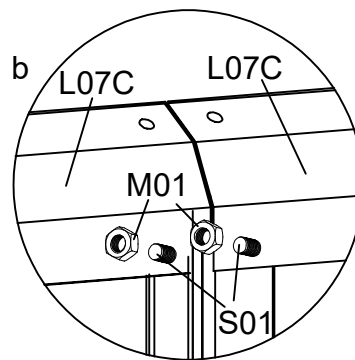
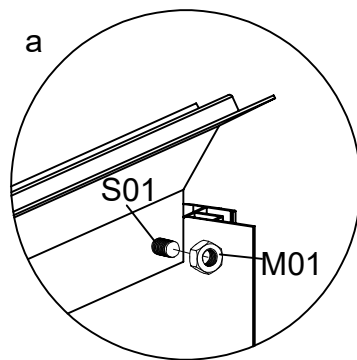
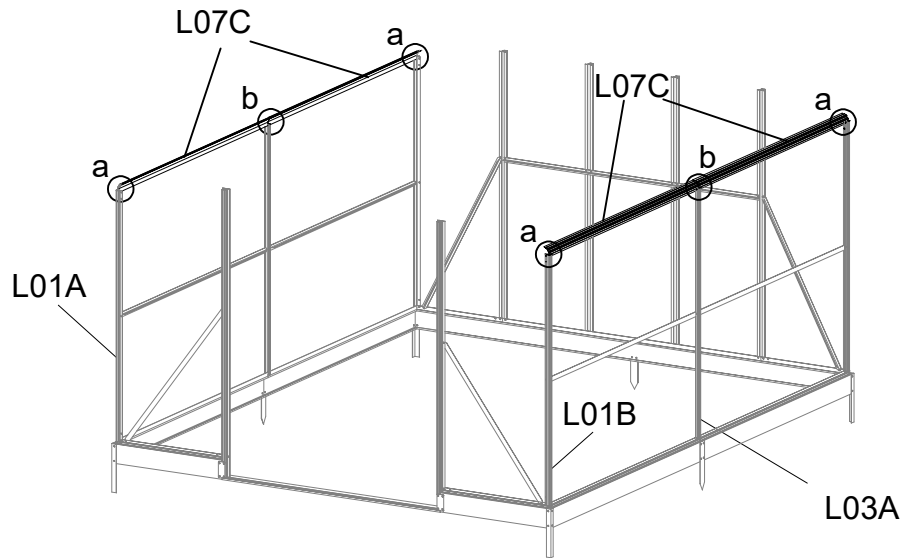
Fix L07C \* 2PCS onto L01A, L03A & L01F and L01B, L03A & L01E, using S01 & M01

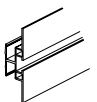

# Wall Assembly

PART	NO	QTY
	L02A	8
	S01 M6X12	40
	M01 M6	40

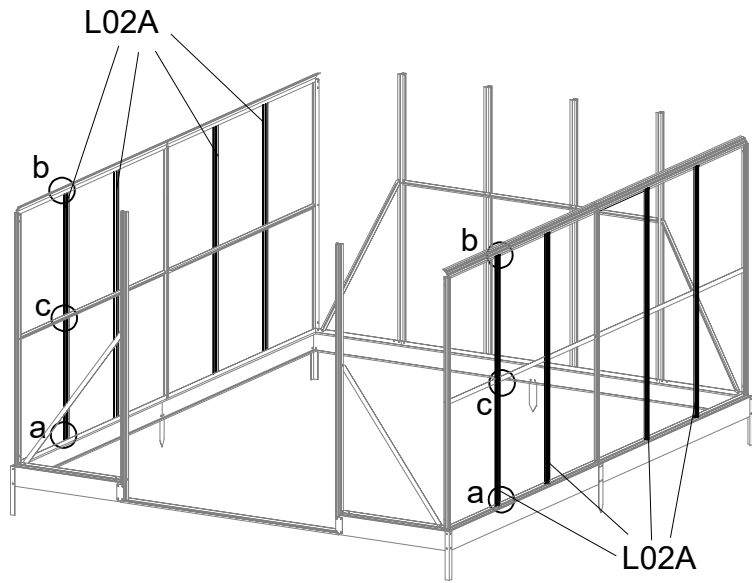



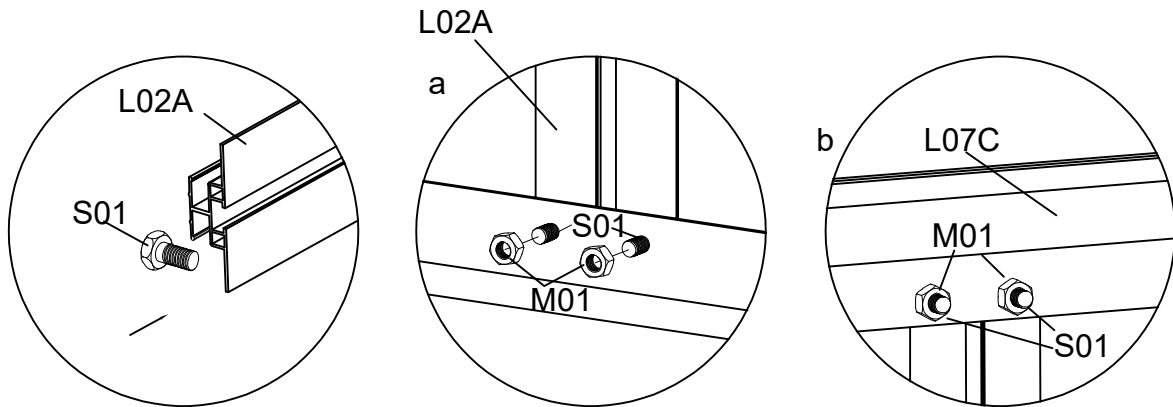

Fix L02A (8pcs) to L08C and L07C using S01 & M01.

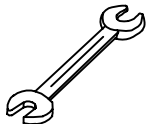
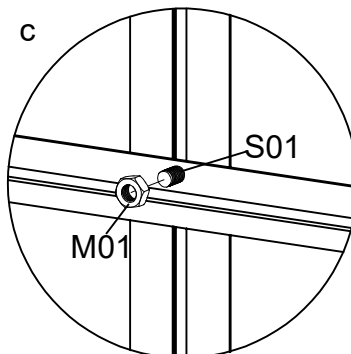

Slide a bolts (S01) into each L02A bolt channel. One is to fix L23C

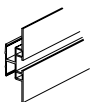



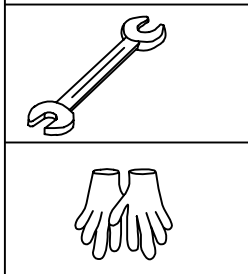
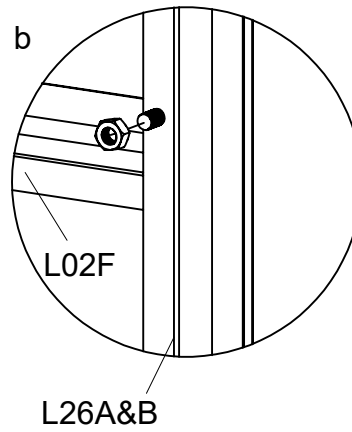
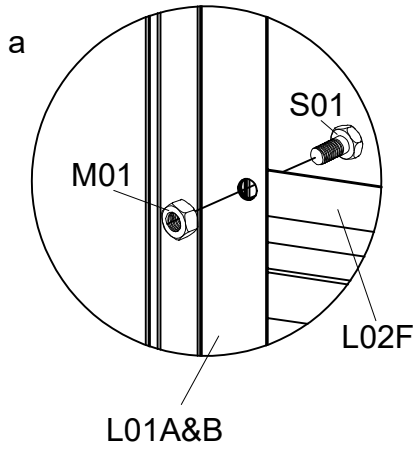
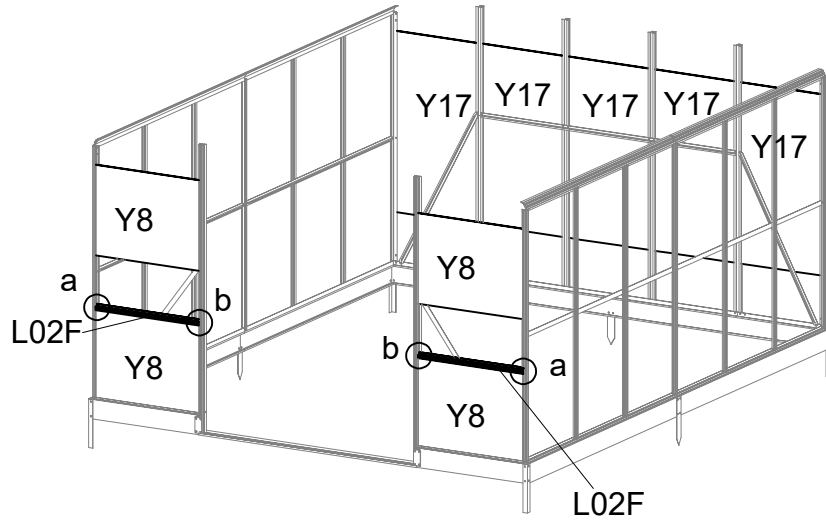

# Wall Assembly



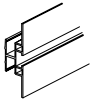





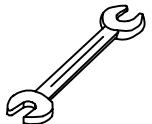
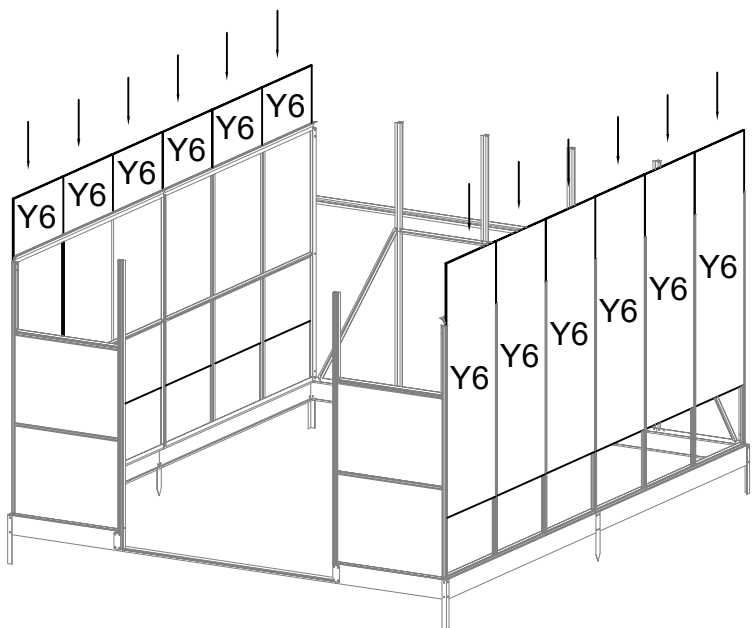
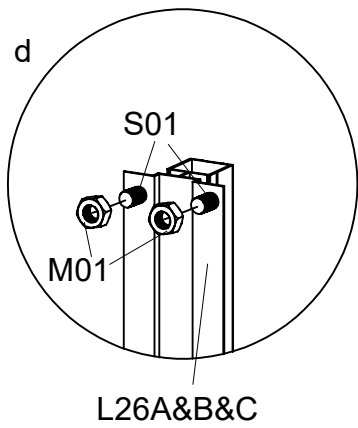
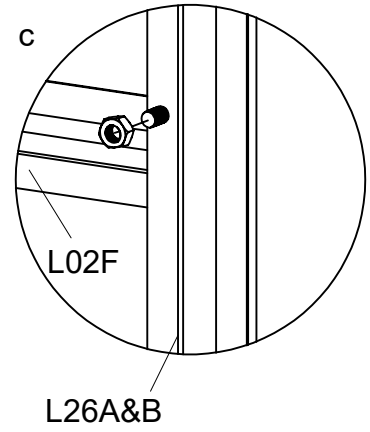
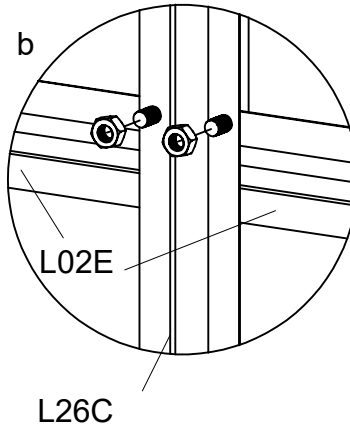
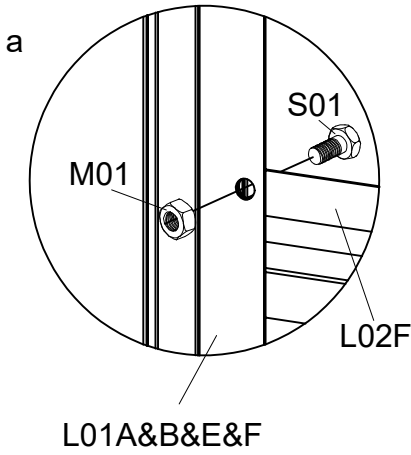
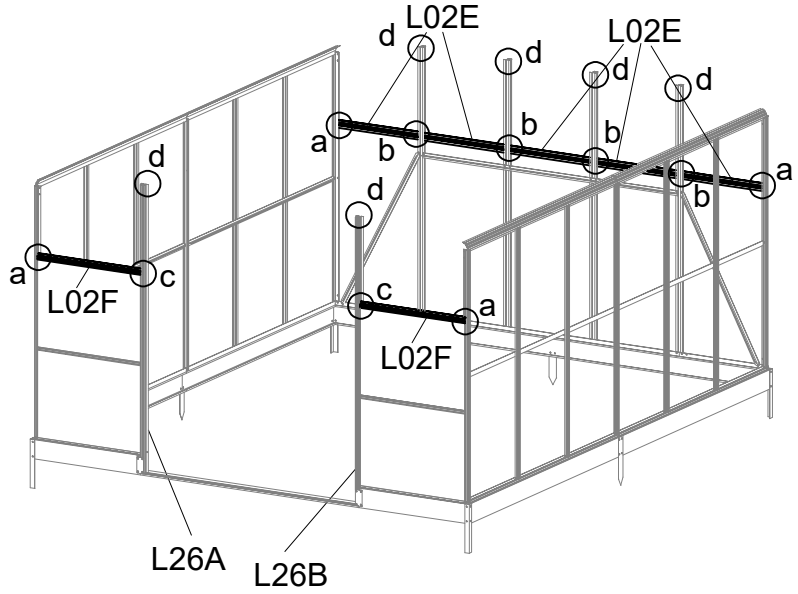

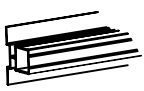
PART	NO	QTY
	L02F	2
	Y8	4
	Y17	5
	S01	4
	M6X12	
	M01	4
	M6	



# Wall Assembly

PART	NO	QTY
	L02E	5
	L02F	2
	Y6	12
	S01	10
	M6X12	
	M01	10
	M6	



PART	NO	QTY
	L26D	1
	L26E	1
	L26F	1
	L26G	1
	Y4	1
	Y5	1
	Y14	1
	Y15	1
	Y18	3
	A114	2
	S01	8
	M6X12	
	M01	8
	M6	
	S26	8
	M5X12	

Put the panels into positions

# Wall Assembly

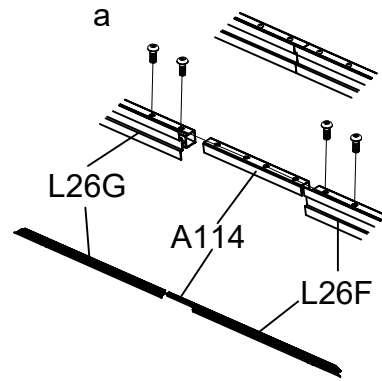
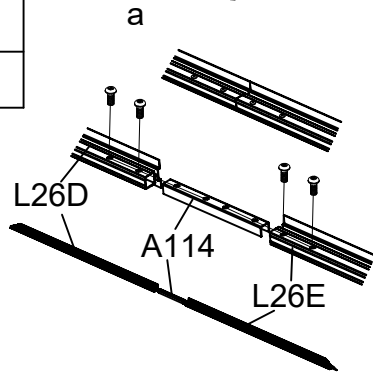
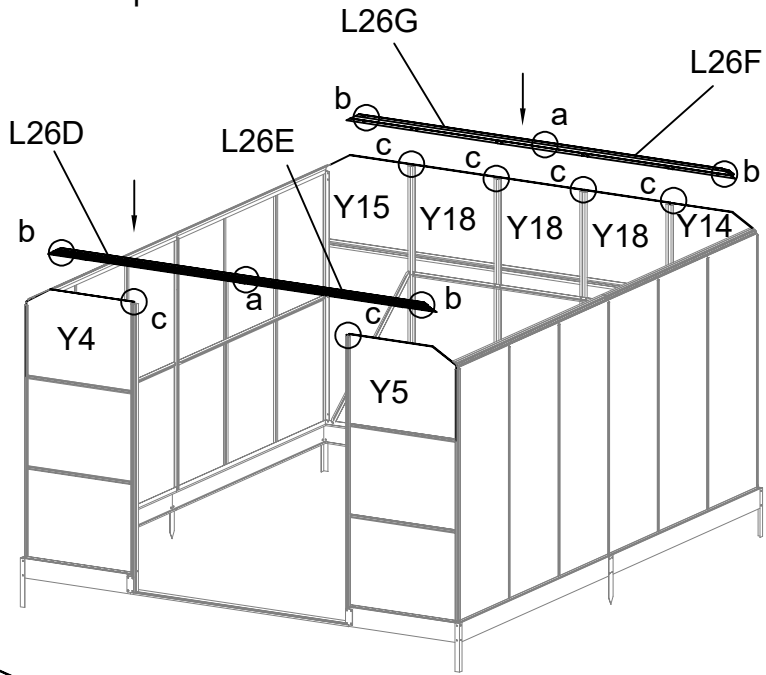

Put the panels Y4, Y5, Y14, Y15 and Y18 into positions.

**!Attention:**

Please pre-load S01 & M01 on L26D, L26E, L26F & L26G before putting panels Y4, Y5, Y14, Y15 & Y18 into position.

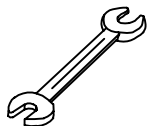
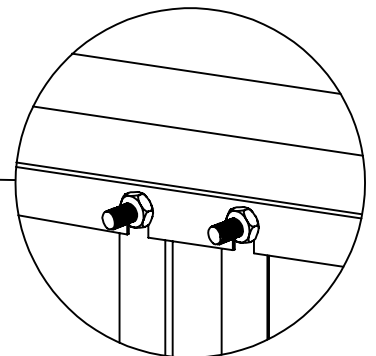
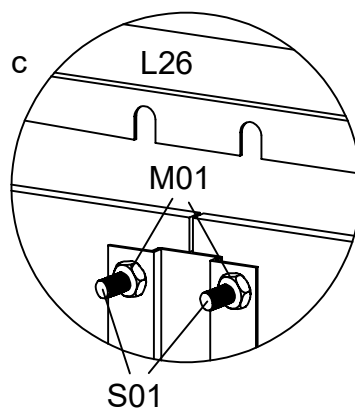
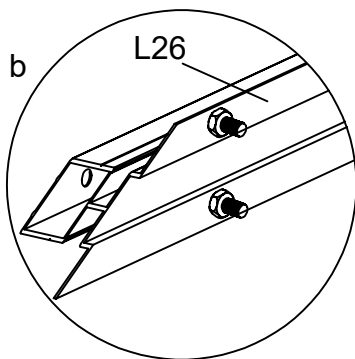

Loose the nuts M01 on L26C, L26D, L26E & L26F to allow L26C, L26D, L26E & L26F fitted in. After the screws are inserted into the U-shaped opening, it is necessary to adjust the structure and lock it.

PART	NO	QTY
	L02C	2
	L02D	2
	Y1	2
	Y2	2
	Y3	2
	S01 M6X12	16
	M01 M6	16

# Top Assembly

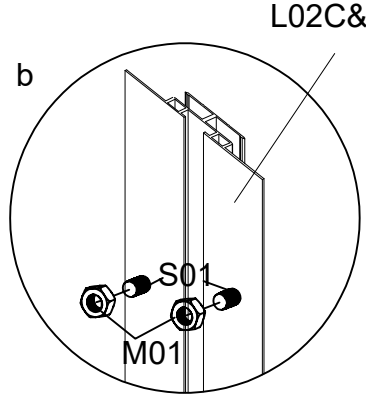
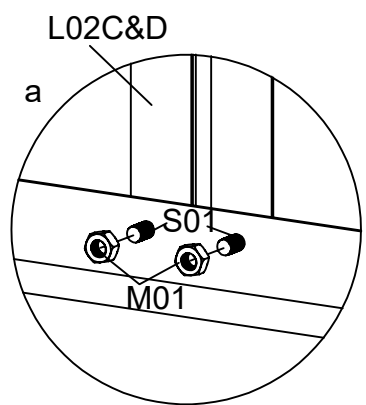
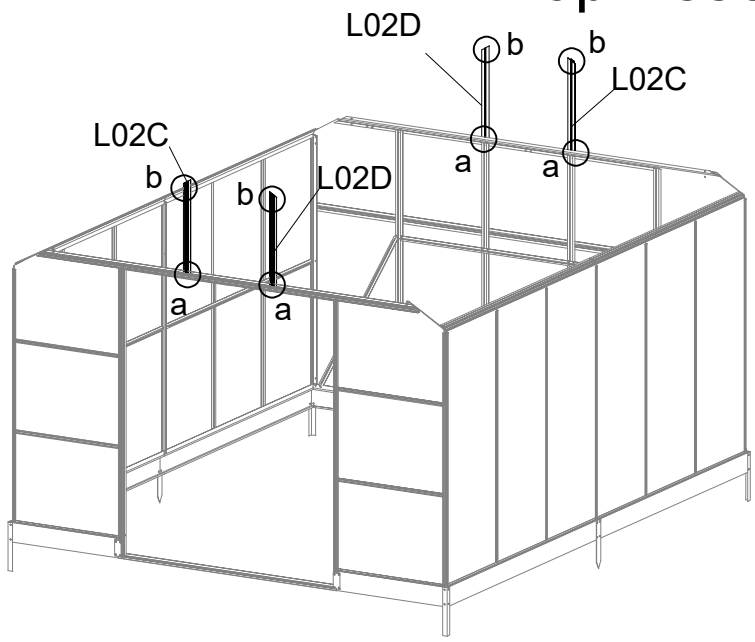

Preload S01 & M01 on L02C and L02D before fixing them to L01C/L01D. See figure b.





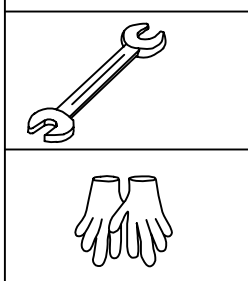
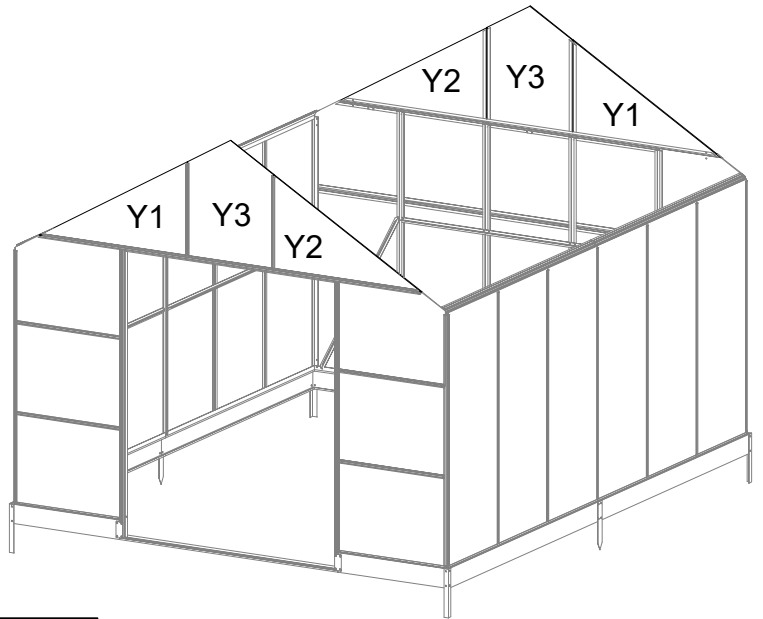

**! Attention:** Remove the protective films from both sides of each polycarbonate panel, before inserting into aluminum channels. Ensure the milky white film faces towards the Sun.

Put the glazing panels Y1, Y2 & Y3 into positions.

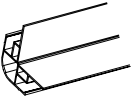

# Top Assembly

PART	NO	QTY
	L01C	2
	L01D	2
	D17	2
	D38	4
	D309	4
	S01 M6X12	28
	M01 M6	28

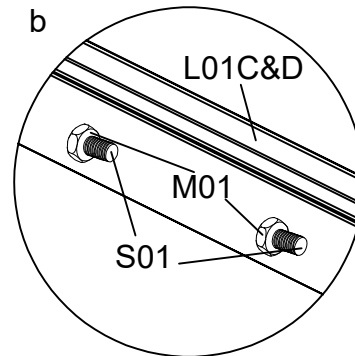
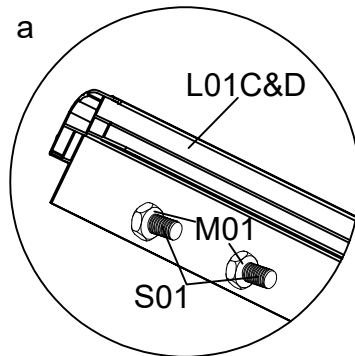
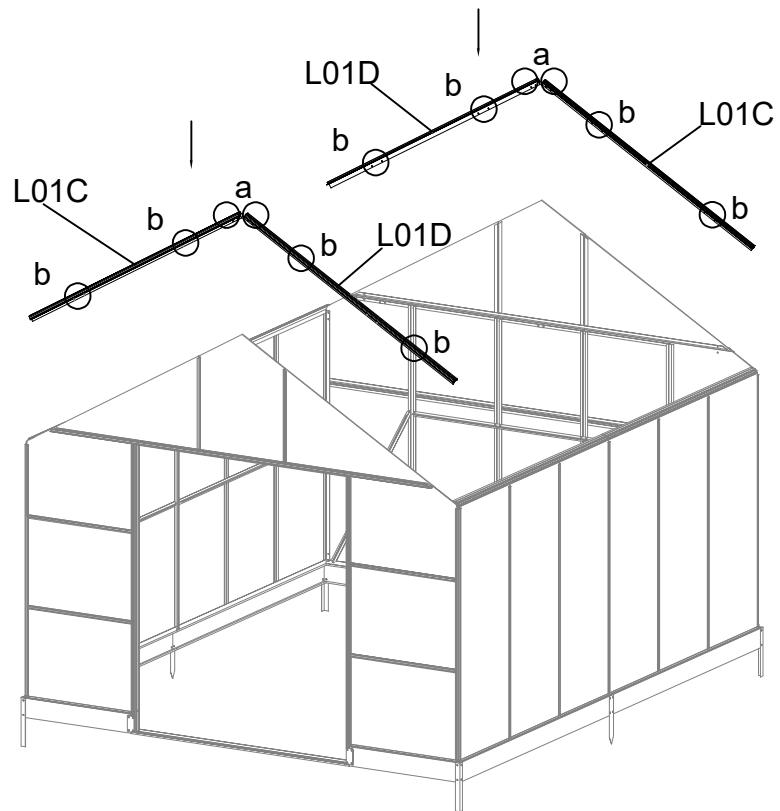

-  1. Preload S01 & M01 on L01C and L01D before fixing them to L01A/L01B. See figure a & b.

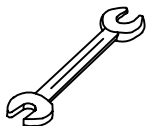



# Top Assembly

If the holes are not aligned, it may be due to uneven foundation, adjust the foundation and frame to solve the problem

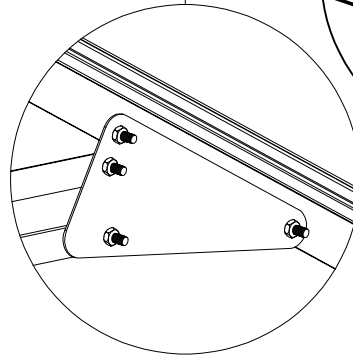
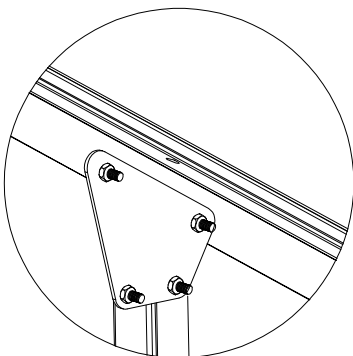
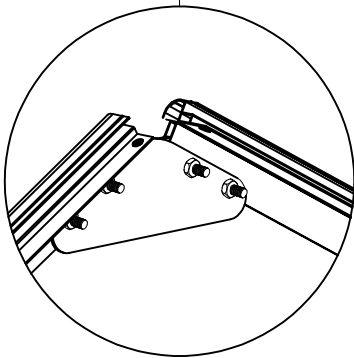
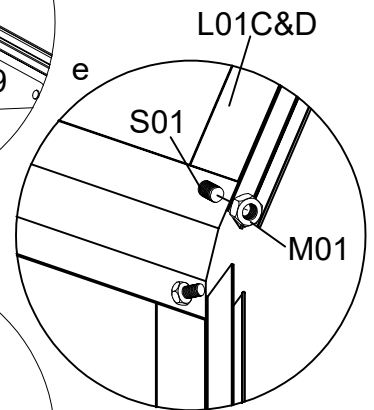
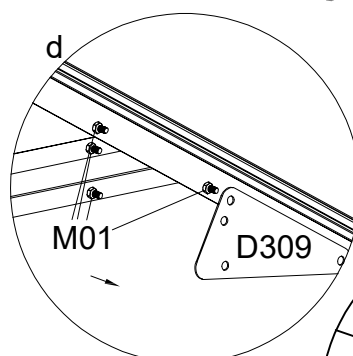
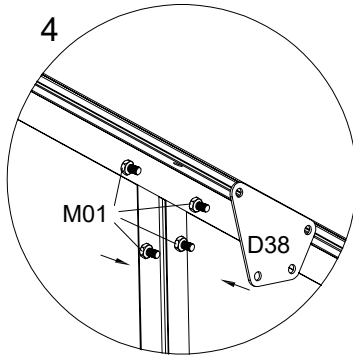
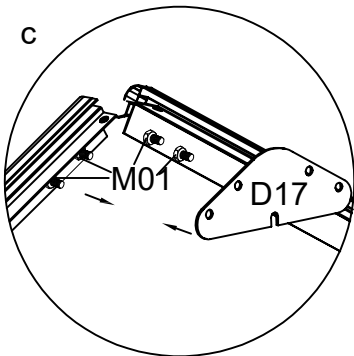
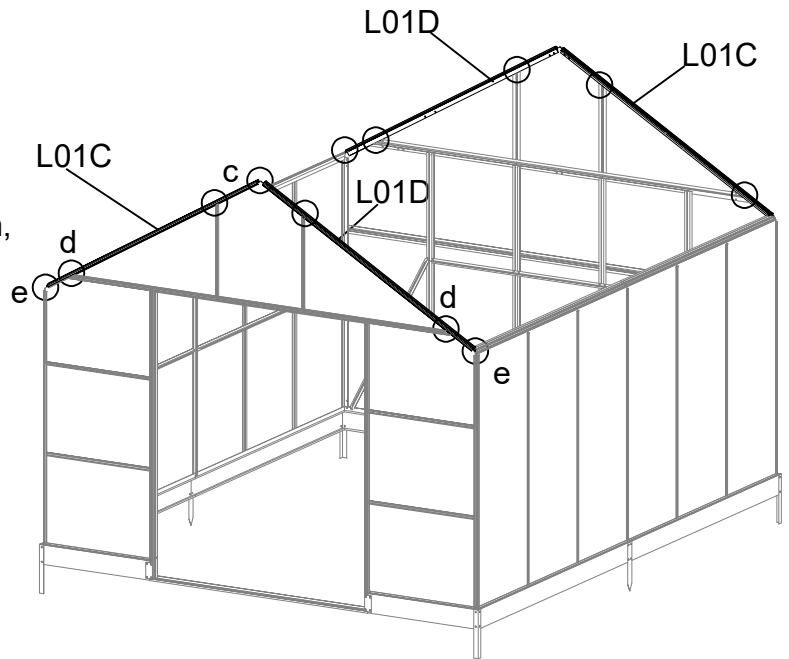





2. Bolt L01C and L01D with plate D17, using S01 & M01 preloaded. And then fix them to L02C, using S01 & M01.

3. Fix L01C & L01D to L26G & L26H with the plate D309, using the S01 and M01 preloaded above.

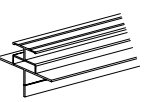
4. Fix L01C & L01D to L01A & L01B, using S01 & M01.



PART	NO	QTY
	L03B	2
	L23E	3
	D17	3
	S01 M6X12	22
	M01 M6	22

# Top Assembly

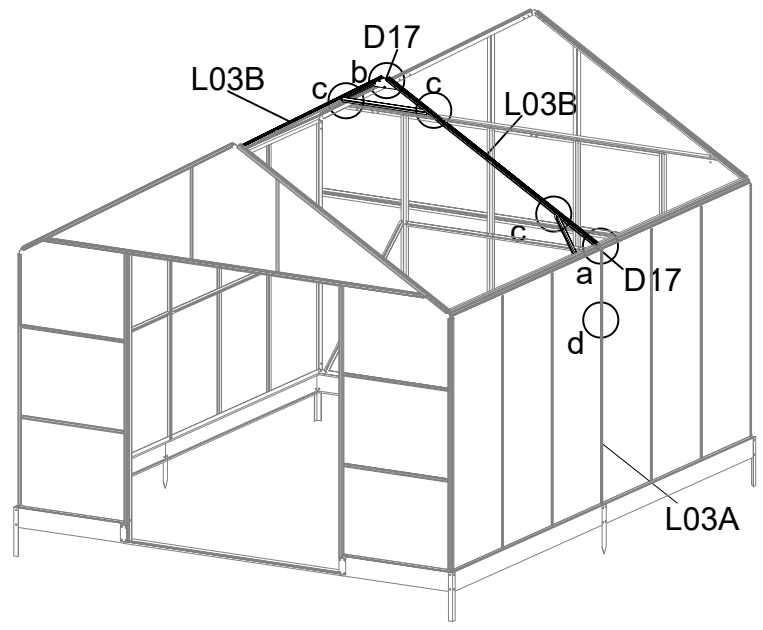

Fix glazing bars L03B to the eaves and the ridge profiles using S01 & M01

Fix plates D17 to L03A & L03B using S01 & M01.

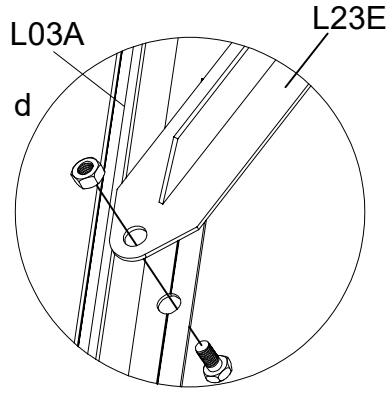
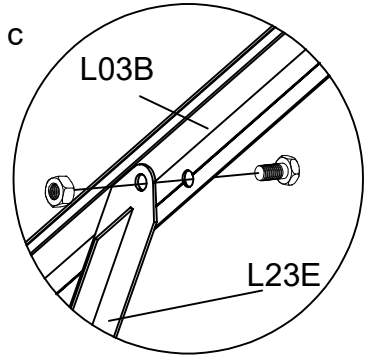
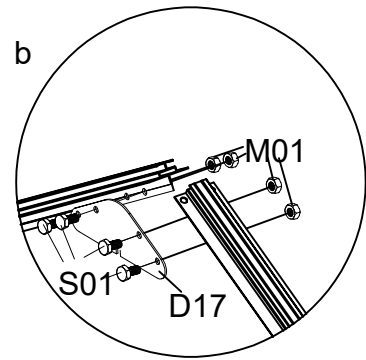
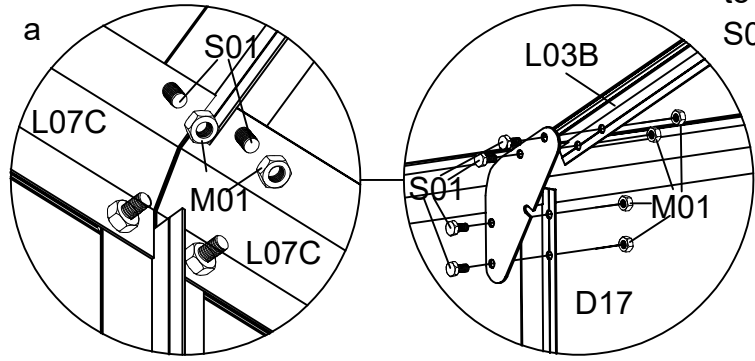

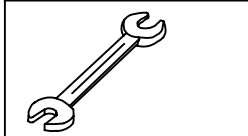

Fix plates D17 to the two L03B using S01 & M01.

Fix L23E to L03A and L03B using S01 & M01.



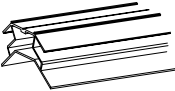

# Top Assembly

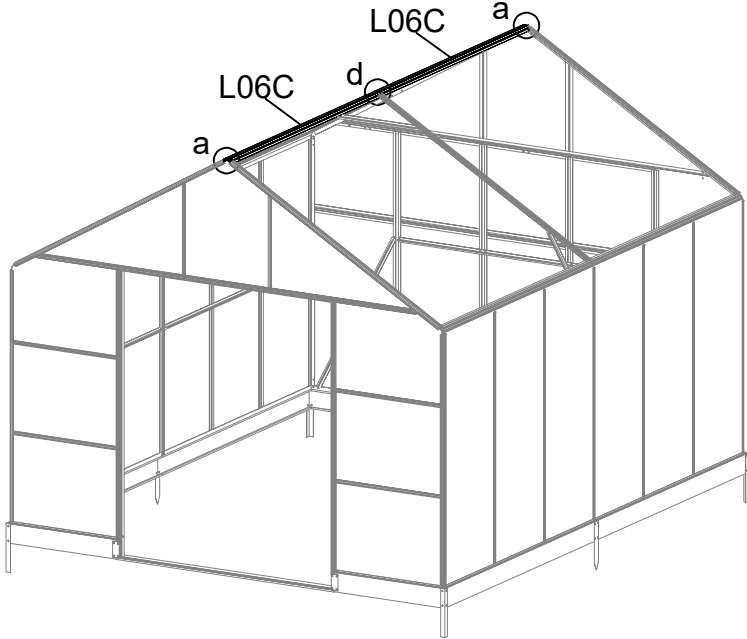
PART	NO	QTY
	L06C	2
	S01 M6X12	8
	M01 M6	8

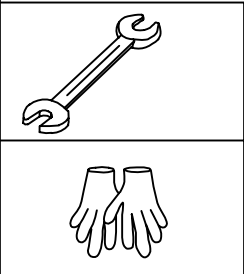
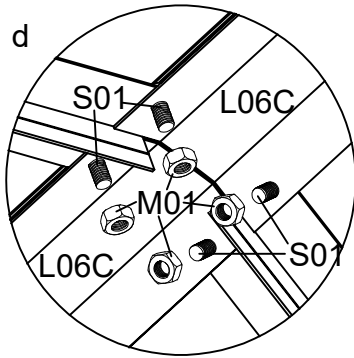
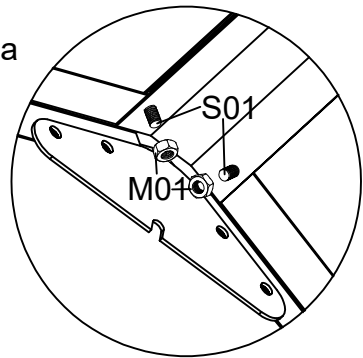

Bolt the ridge L06C (2pcs) to L01C, L01D and L03B, using S01 & M01.

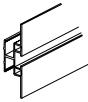

PART	NO	QTY
	L02B	8
	S01 M6X12	48
	M01 M6	32

# Top Assembly

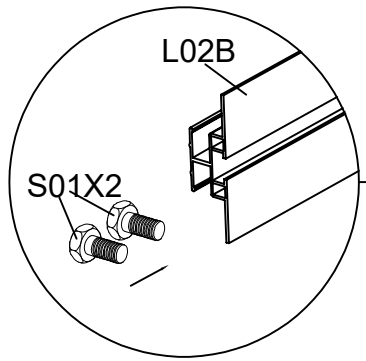
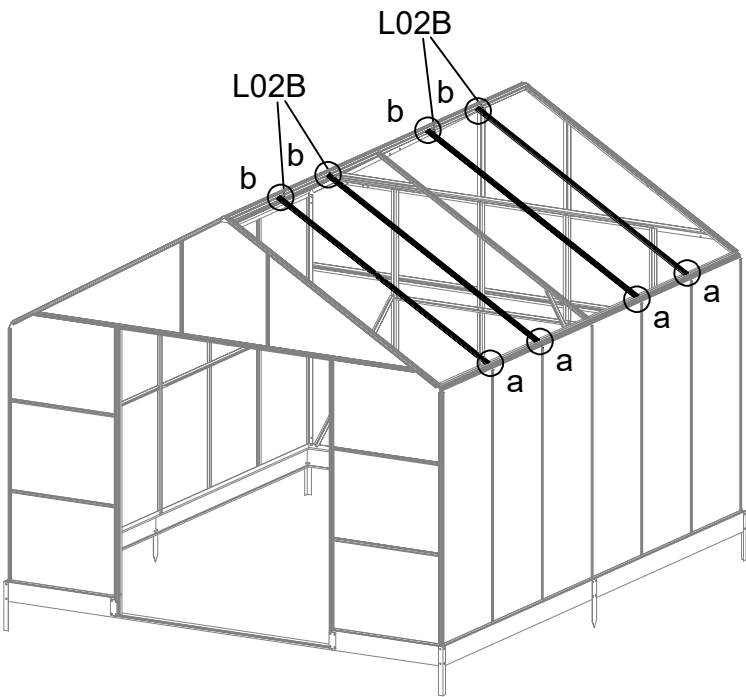



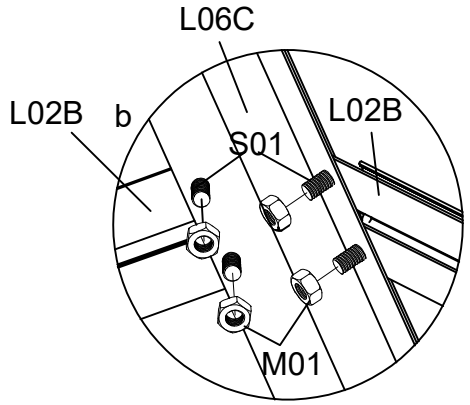
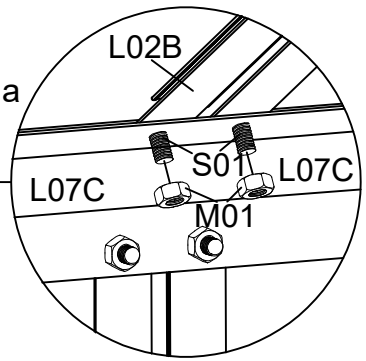

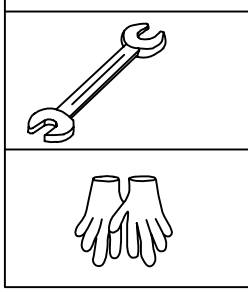

Slide 2 bolts (S01) into each L02B bolt channel to be used later.



Fix glazing bars L02B (8pcs) to the eaves and the ridge profiles with S01 & M01



PART	NO	QTY
	L23C	4
	L05B	4
	D26	1
	S01 M6X12	8
	M01 M6	24
	Z08 M4.2X16	2

# Top Assembly

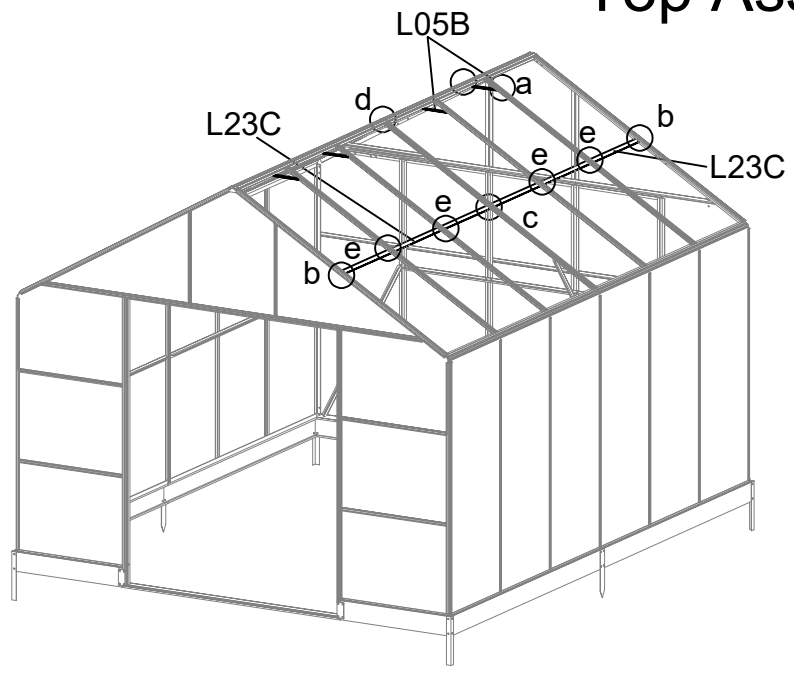

Bolt L05B (d pcs) to L02A & L02B using the S01 bolt placed in the bolt channel earlier.

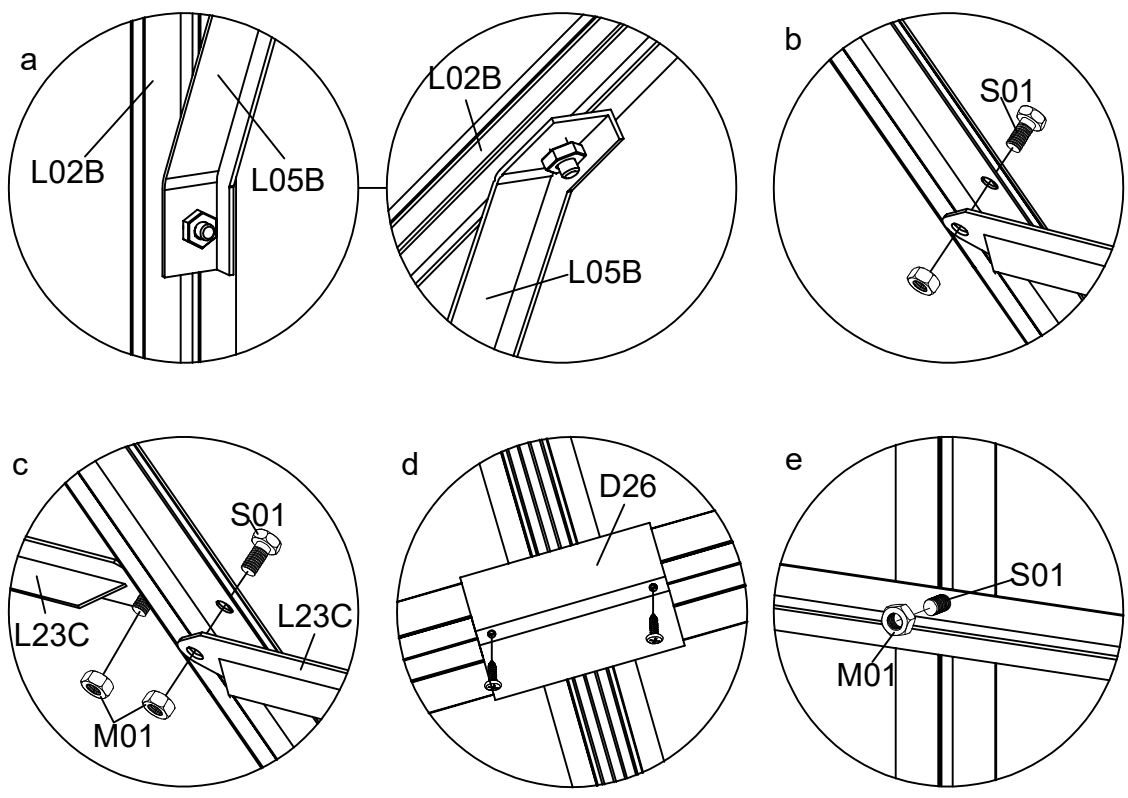





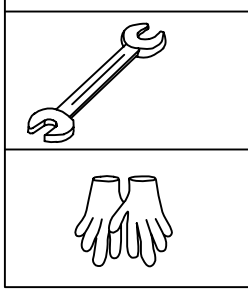

Bolt L23C to L01C/L01D & L03B with S01 & M01.

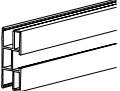
Fix D26 to L06C from outside with self-tapping screws Z08, using a powered screwdriver.

Bolt L23C to L02B using the S01 bolt placed in the bolt channel earlier.



PART	NO	QTY
	L04A	4
	A03	4
	WINDOW	4
	Y7	8
	Y9	8
	S01 M6X12	24
	M01 M6	24

# Top Assembly

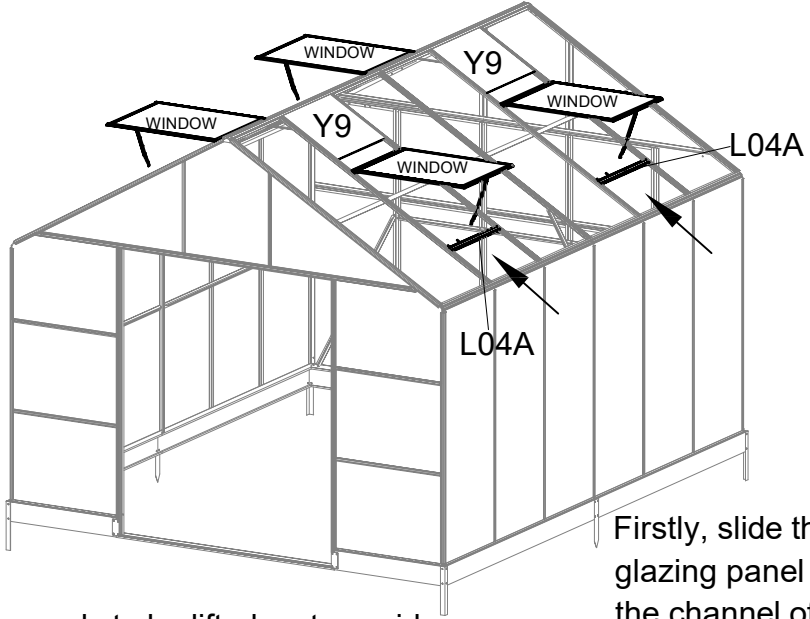

Firstly, slide the glazing panel Y9 into the channel of L02B/L03B

When installing L04A, the window needs to be lifted up to avoid the window not opening after the installation is complete

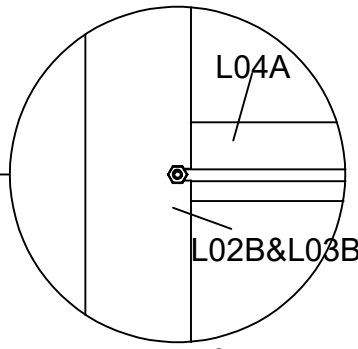
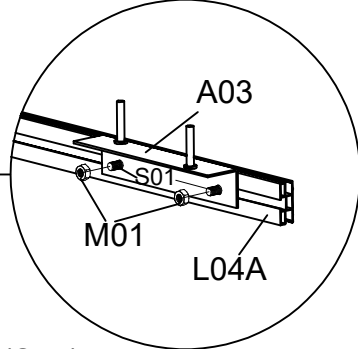
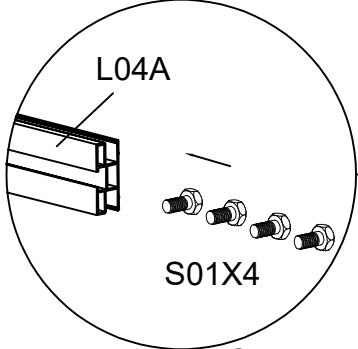



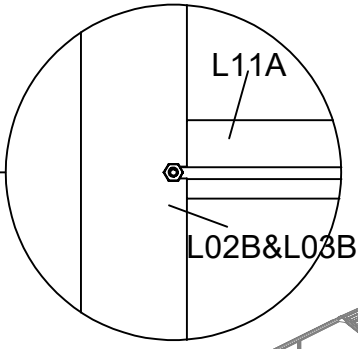
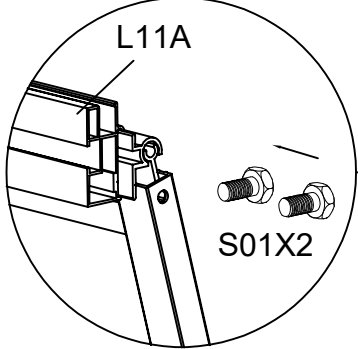

Slide 4 bolts (S01) into each L04A bolt channel. 2 to be fixed with A03, and another 2 to be fixed with L02B/L03B.

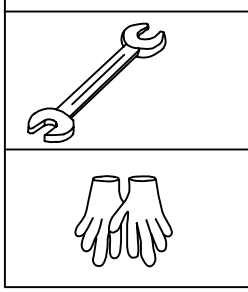
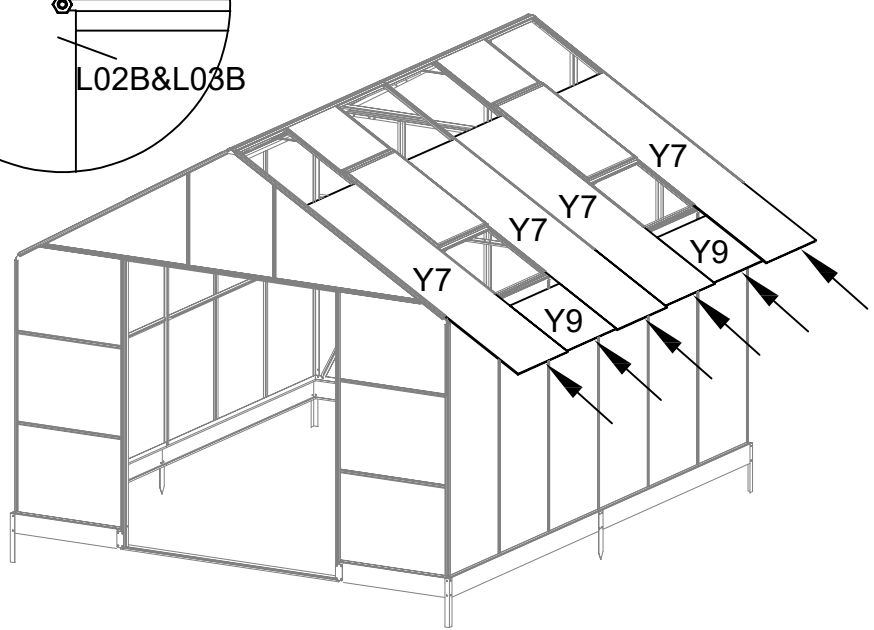

Slide the glazing panels into positions

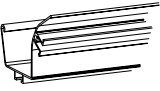
Slide 2 bolts (S01) into each L11A, and bolt it to L02B/L03B, using the S01 & M01.



PART	NO	QTY
	L09C	4
	D25	2
	S01 M6X12	4
	M01 M6	4

# Top Assembly

After the panels and windows are in position, put some silicone sealant around to avoid leaking water.

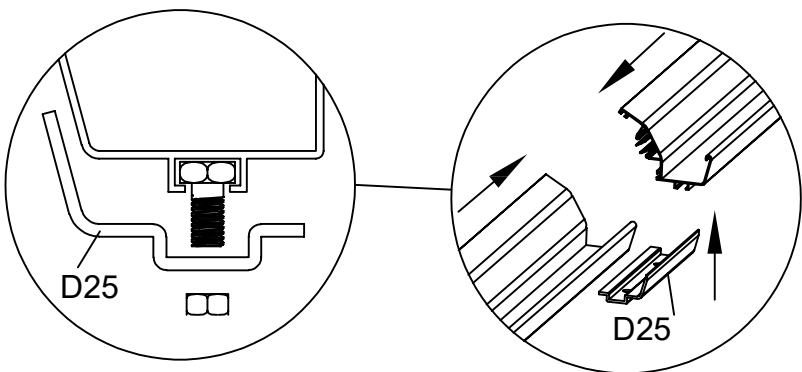
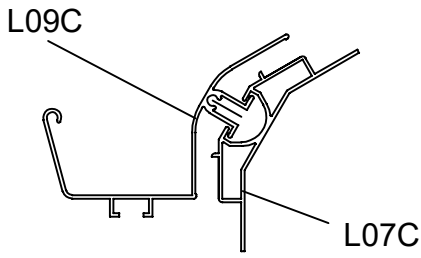
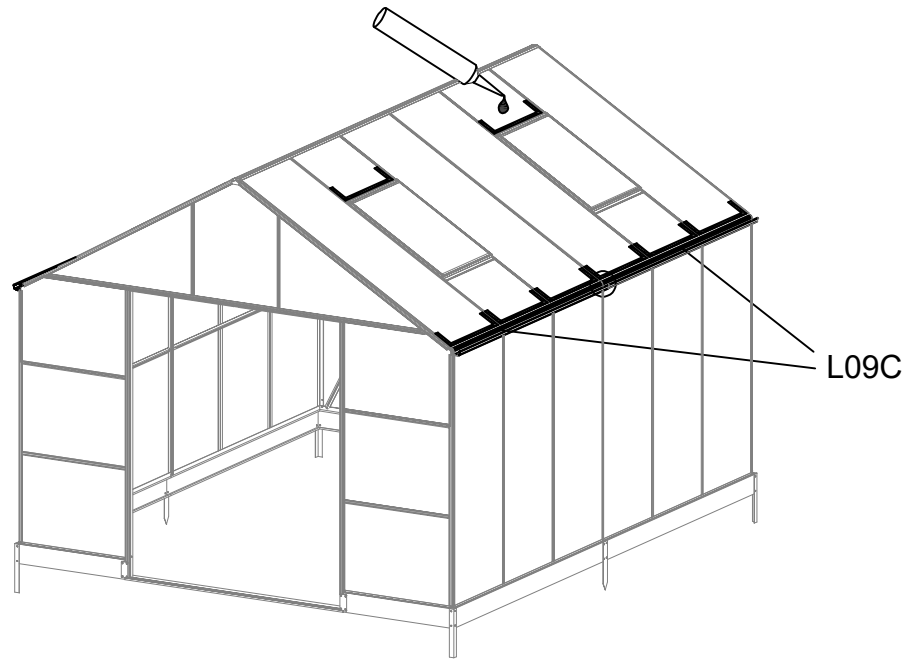



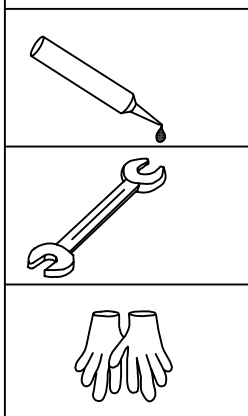

When the panels are completely inserted, fix gutter profile L09C. Tap it gently into position with a rubber mallet.

Slide 1\*S01 into the bolt channel of both L09C, fix D25 to L09C using S01 & M01.



# Door Assembly

PART	NO	QTY
	D00R-L	1
	D00R-R	1
	A51	4
	Z17 M4.8X16	8
	S27 M5X12	24

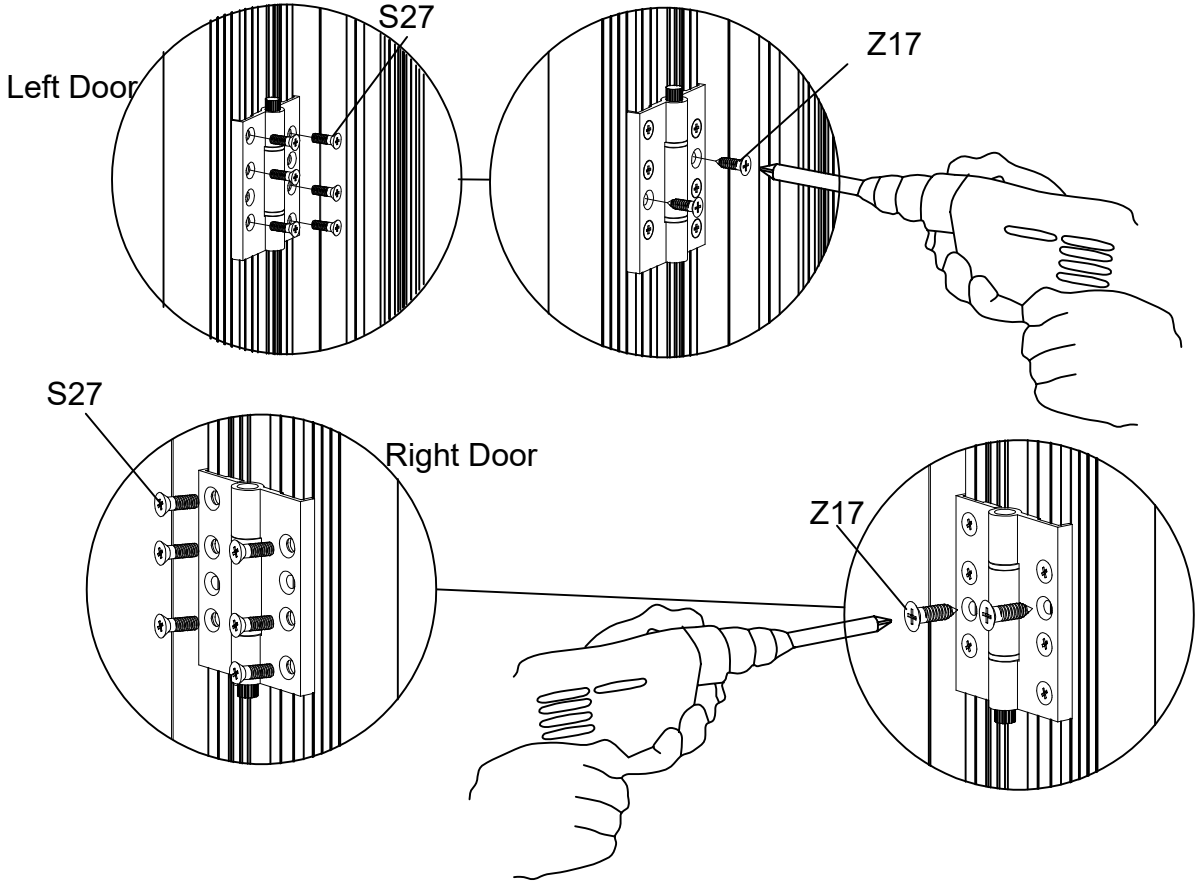
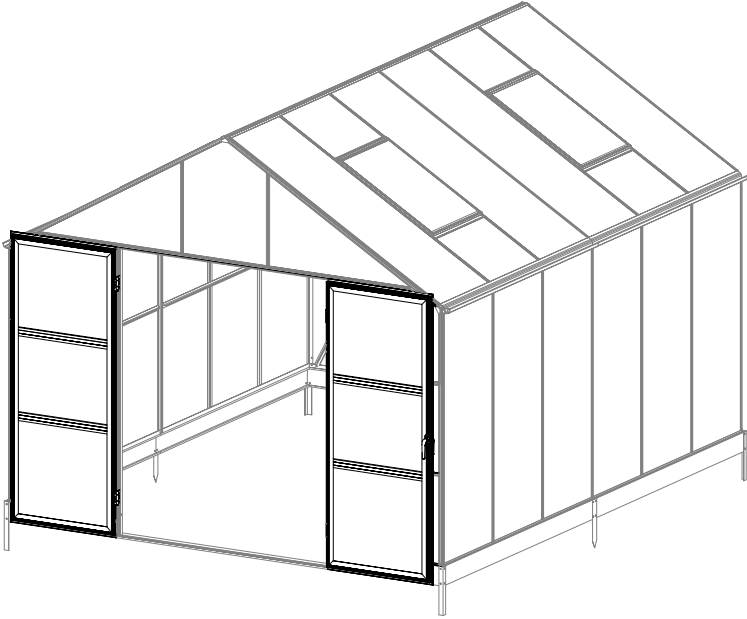

Fix A51(4 PCS) one side on the door profile and the other side to L26A/L26B using S27. Then secure with Z17.

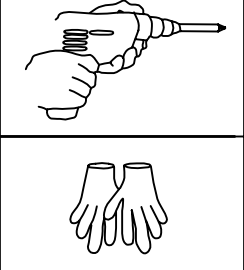



# Accessories Assembly

PART	NO	QTY
	J55	2
	J56R	2
	J56L	2
	J94	4
	L25	4
	J93	4
	J165	4
	J166	4
	Z08	4
	M4.2X16	
	Z02	8
	Ø4X16D	

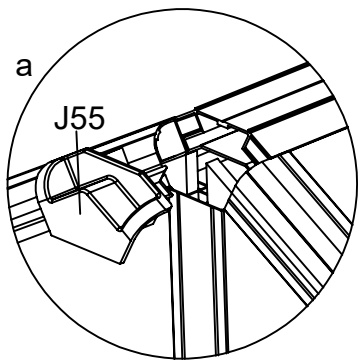
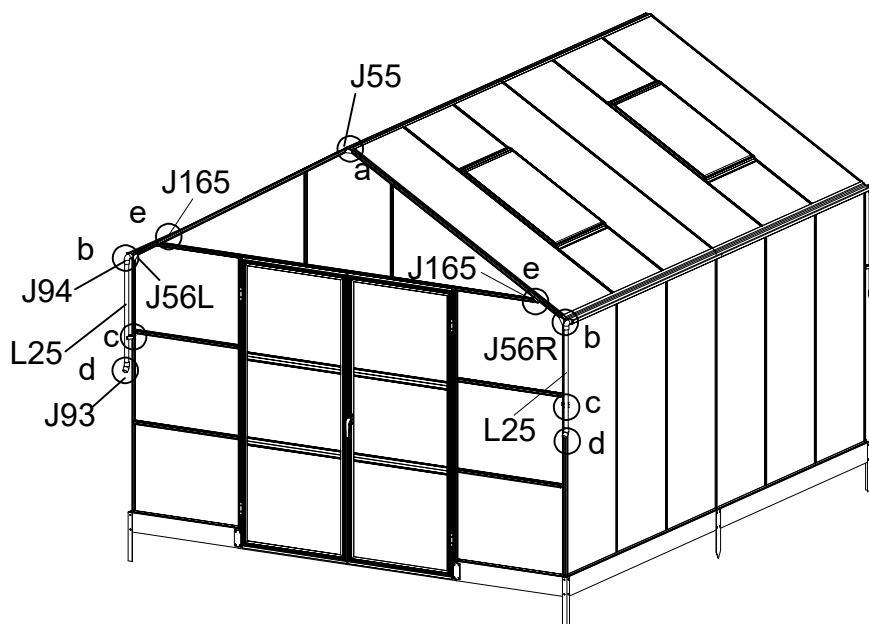

Fix the cover caps J55 into the ridge profile

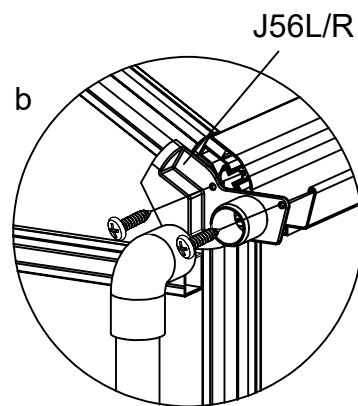

Fix the cover caps (J56L/R) carefully with Z02. Be careful to ensure that the screws are driven in straight and in the correct position (see detail drawings).

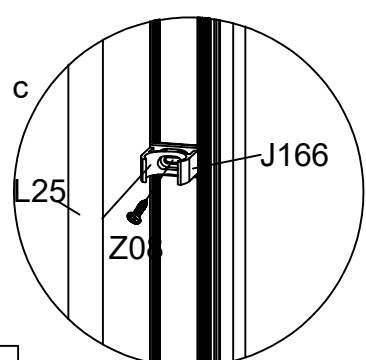

Drill a hole in L01A/L01B, approximately 3mm diameter and 400mm down from the gutter. Fix the J166 downpipe bracket with Z08 screws and then clip the L25 downpipe into the J166 bracket.

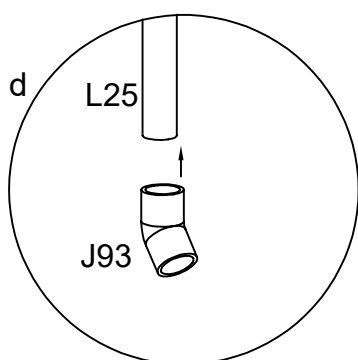

If you wish to eliminate leaks, use glue when fixing the downpipe bends (not provided).

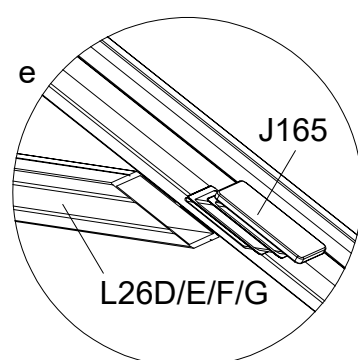

Cover both ends of L26D/E/F/G with cap J165

