

# CONTEMPORARY SOFA

## Assembly Instruction

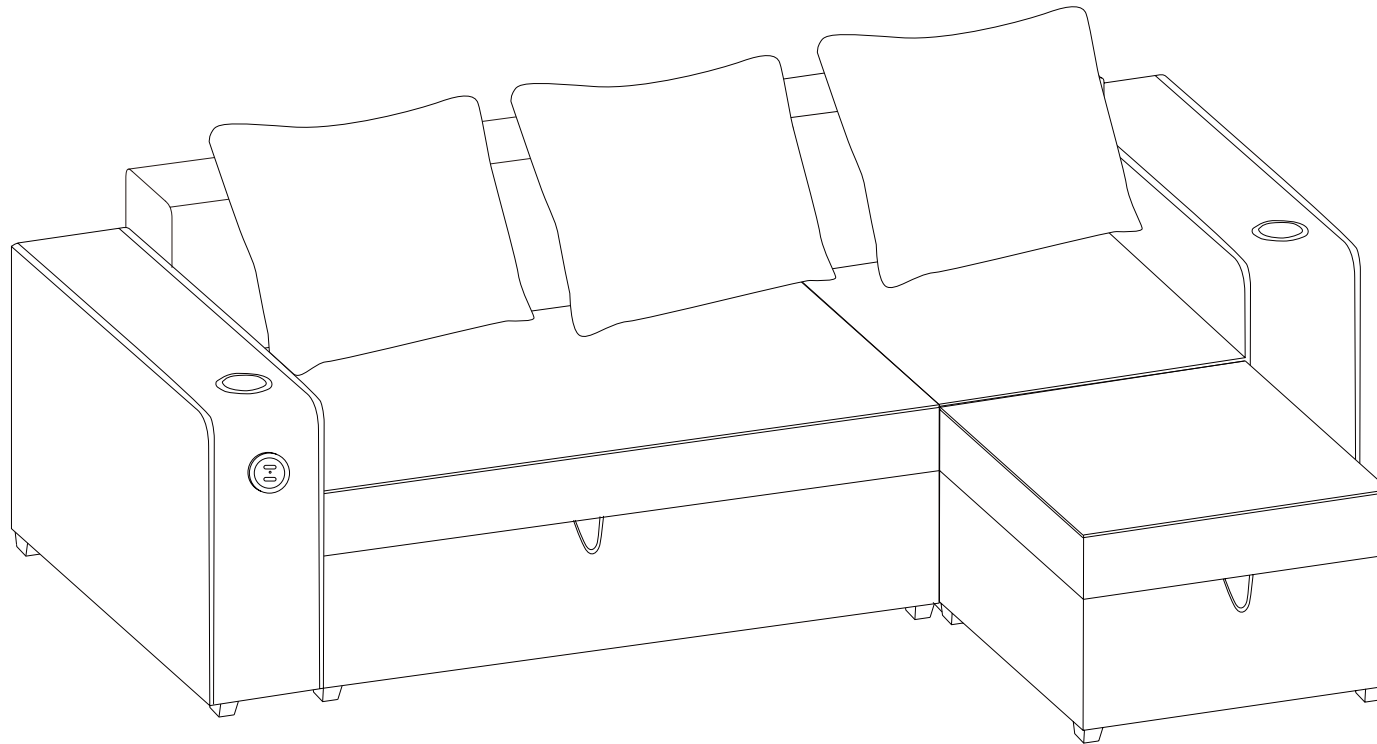

### NOTE:

Delivered with MULTIPLE PACKAGES with MULTIPLE TRACKINGS, may NOT be delivered at the same time.

**Any question please feel free to contact us:  
support@merluxyhome.com TEL:901-347-2181  
We will provide further assistance within 24 hours.**



# Safety and Care Advice

**Important – Please read these instructions fully before starting assembly**

Thanks for your purchase. Before the assembly, please follow the instructions to check if all the spare parts and screws are intact.

- Considering the size and weight of the sofa, we recommend two adults to assemble the sofa, on a carpeted or padded area, in the room that it is intended for. Approximate assembly time: 30 minutes.
- Keep all components and packaging out of reach of children or animals to avoid the risk of choking or suffocation.
- Please do not throw away any of the packaging or the instruction until you have checked all the components and hardware and the furniture is fully assembled. Please ensure that the packaging is disposed in a safe and environmentally friendly way.
- Please do not take off the cover, and do not wash.

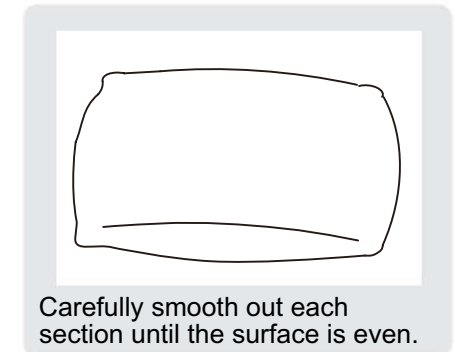
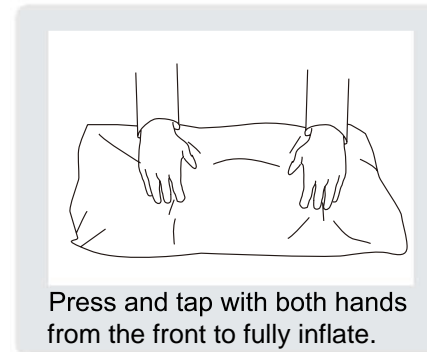
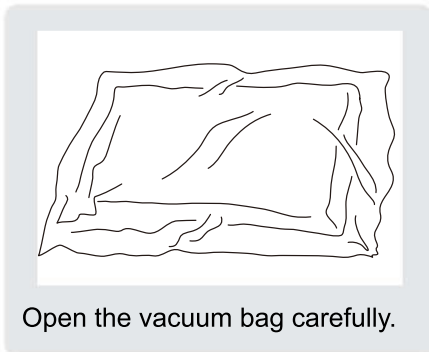

Your cushions come vacuum packed and sealed for shipping. To restore the cushion's original shape, follow the steps below.



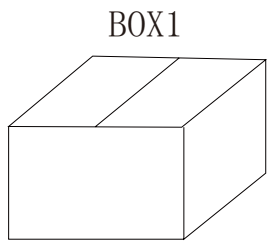



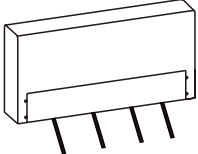

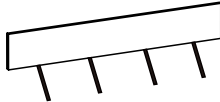
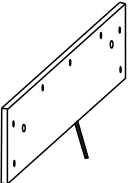
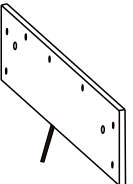
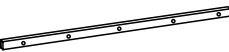
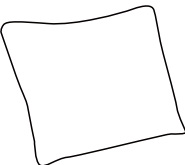



After packing up, place them in somewhere dry and ventilated. After about 72-96 hours. It can be restored to the best use condition.





## Main structure accessories

- A-1**  **Two-seat Backrest** x1
- A-2**  **Two-seat Cushion** x1
- A-3**  **Two-seat Bottom Panel** x1
- A-4**  **Two-seat Front Bezel** x1
- A-5**  **Two-seat Side Bezel(L)** x1
- A-6**  **Two-seat Side Bezel(R)** x1
- A-7**  **Two-seat Iron Pipe** x1
- D**  **Pillow** x2

## Hardware parts

- c**  **M8\*18 Bolt** x16
- d**  **M6\*20 Bolt** x4
- e**  **M6\*20 Bolt** x6
- f**  **M6\*30 Bolt** x5
- g**  **M6\*40 Bolt** x4
- h**  **M8\*22\*1.5 Washer** x4
- i**  **M8 Nut** x2
- j**  **M8\*55 Bolt** x2
- k**  **M6 Allen Key** x1
- o**  **Wrench** x1

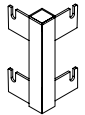
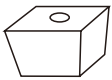
## Structure accessories

- a**  **Connector** x4
- b**  **Sofa leg** x4
- m**  **Connector(L)** x1
- n**  **Connector(R)** x1

BOX2

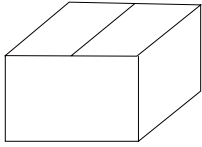

### Main structure accessories

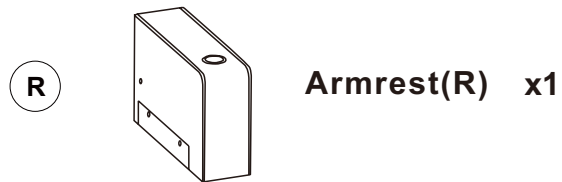
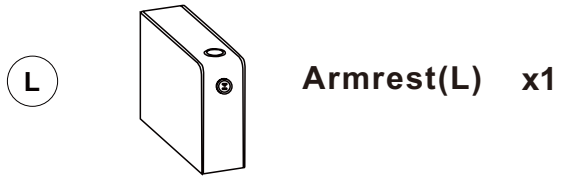

### Structure accessories



### Hardware parts

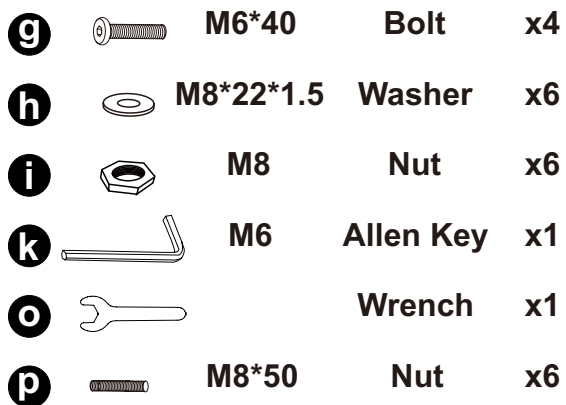

BOX3

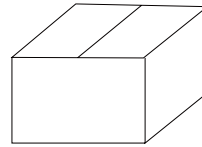

### Main structure accessories

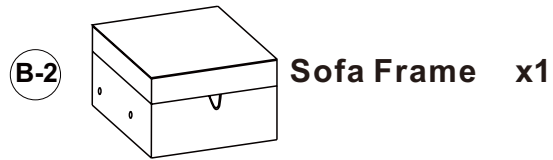
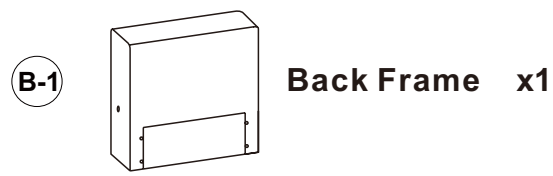

### Structure accessories



### Hardware parts

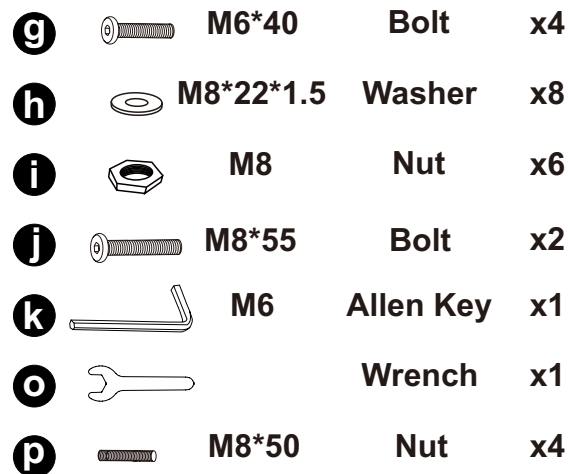

BOX4

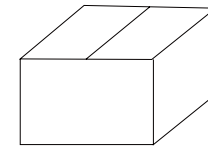

### Main structure accessories



### Structure accessories



### Hardware parts

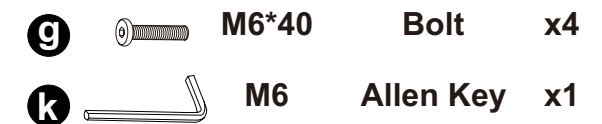

# TWO-SEAT

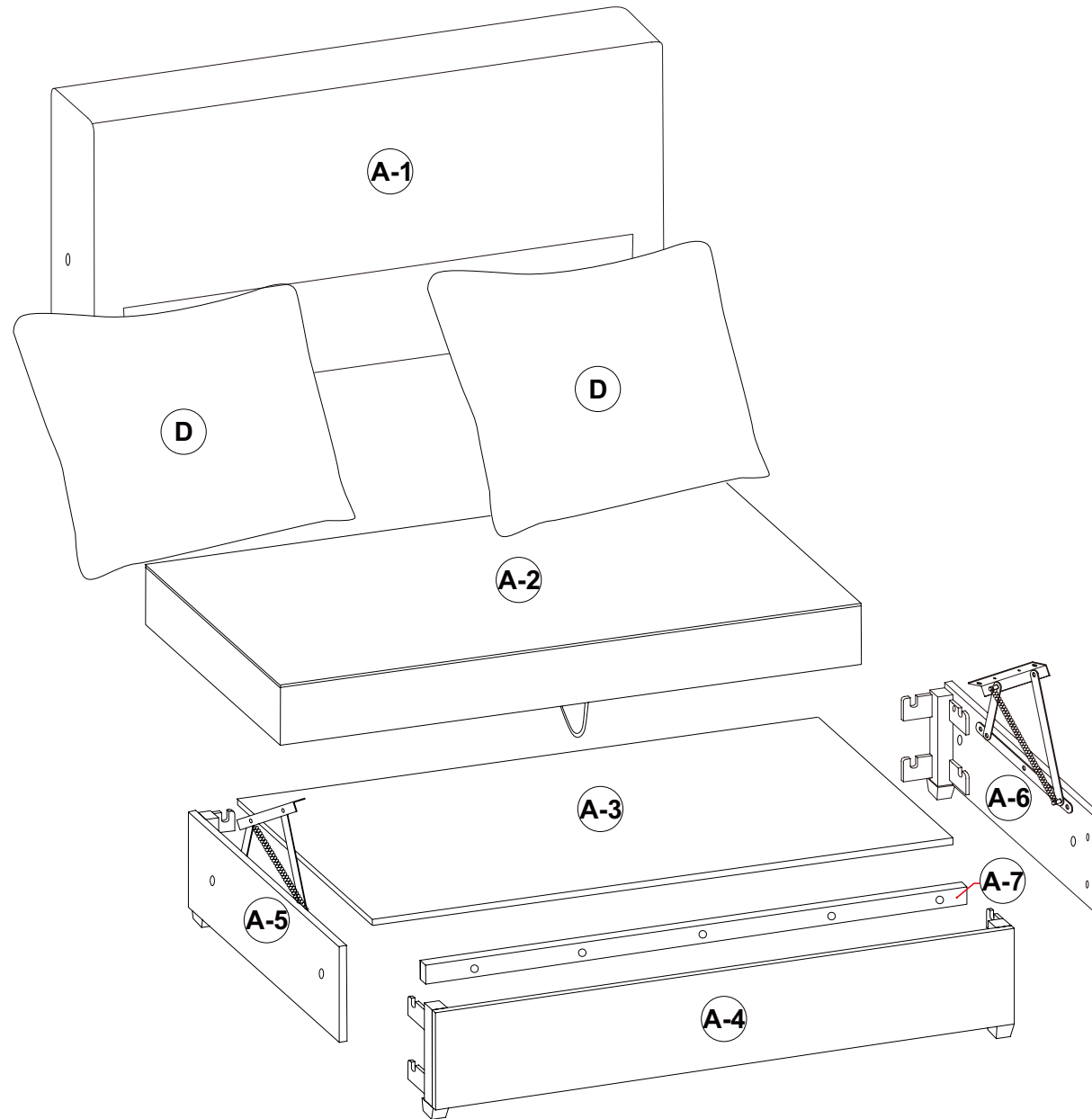

# Main structure accessories

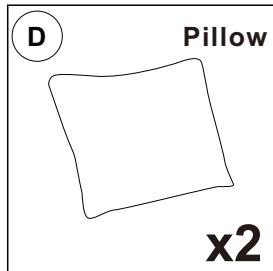
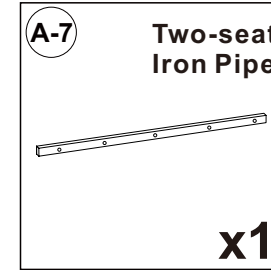
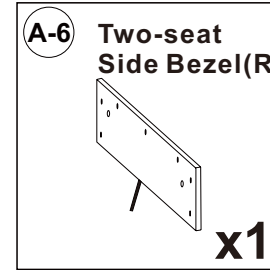
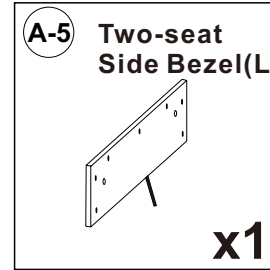
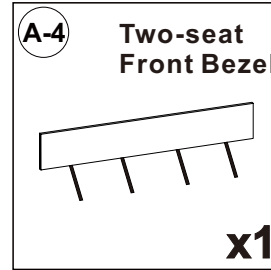
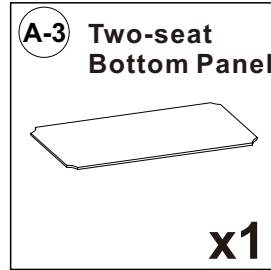
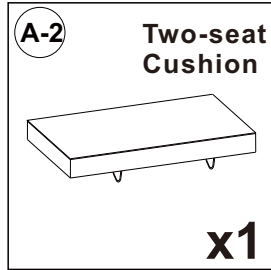
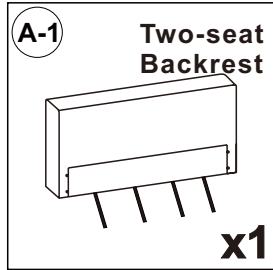

# Structural accessories

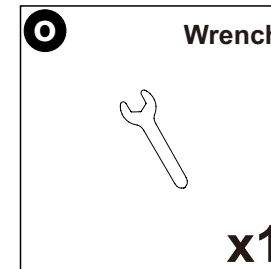
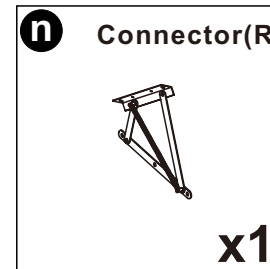
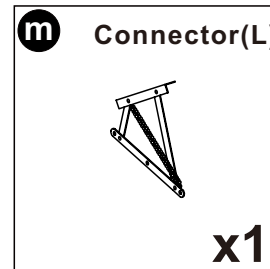
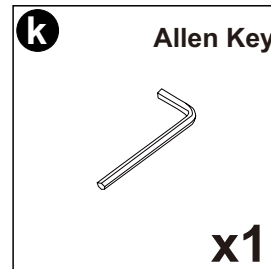
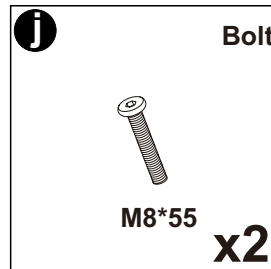
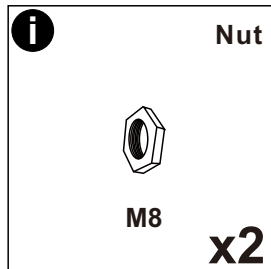
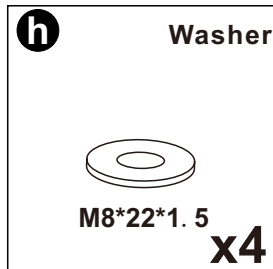
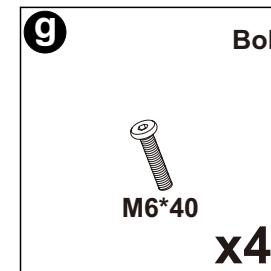
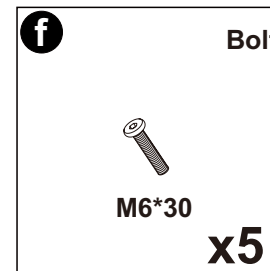
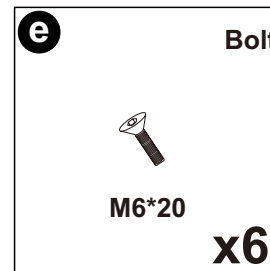
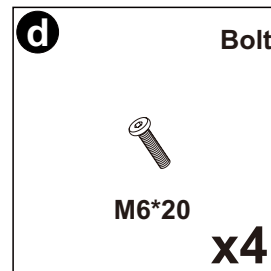
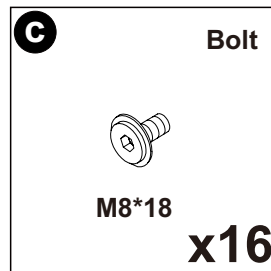
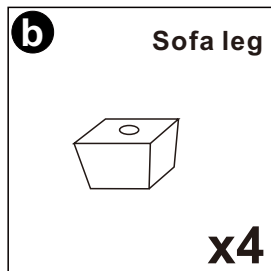
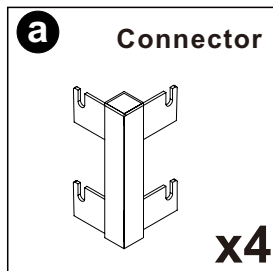

### STEP 1

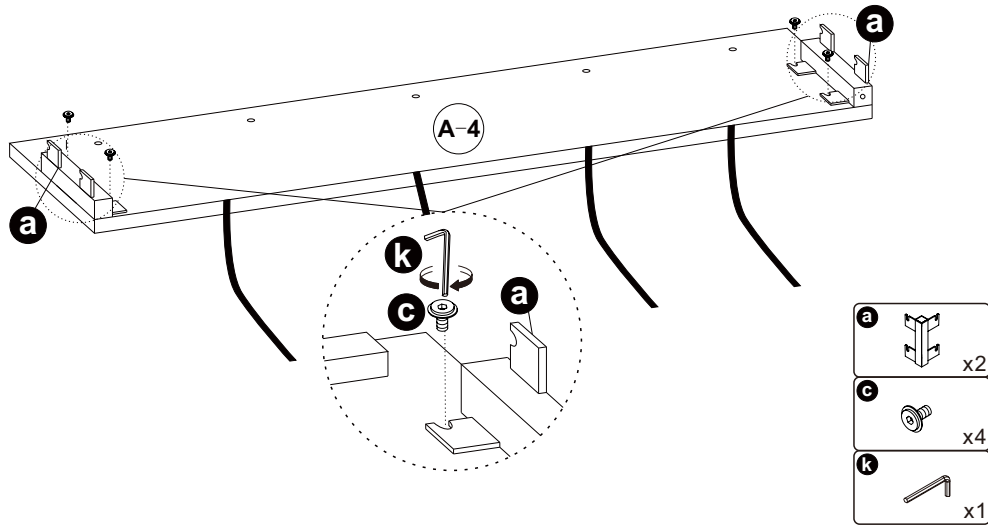

### STEP 2

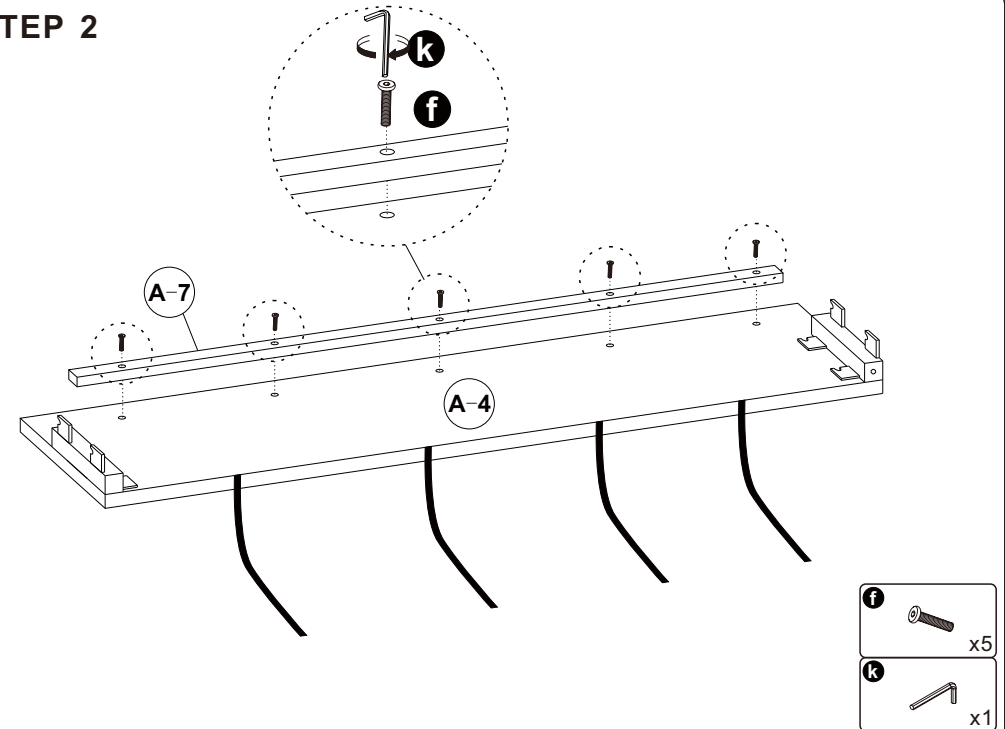

### STEP 3

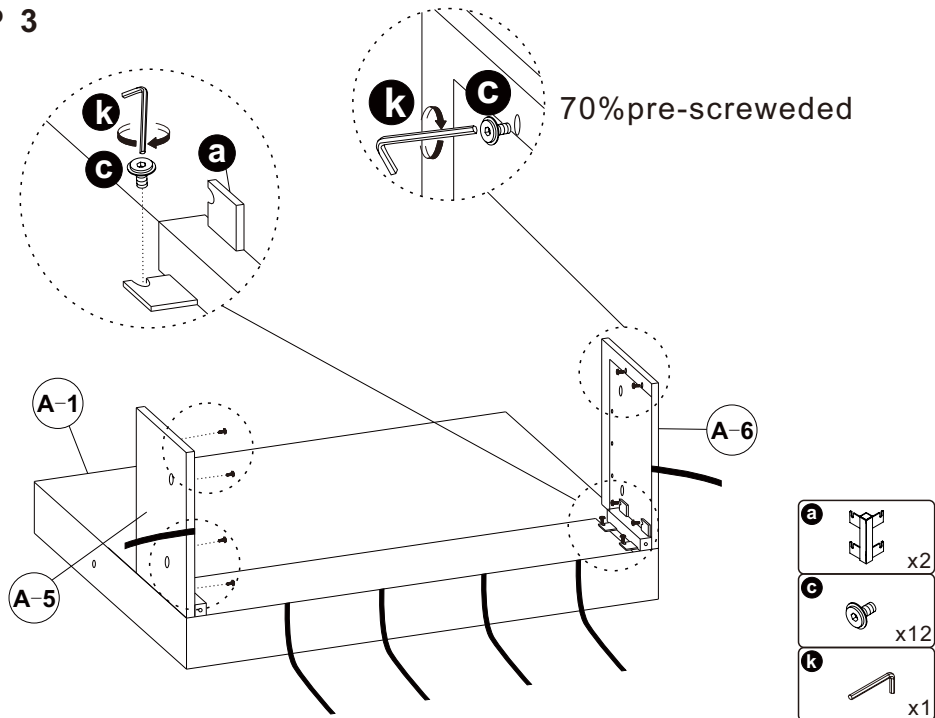

### STEP 4

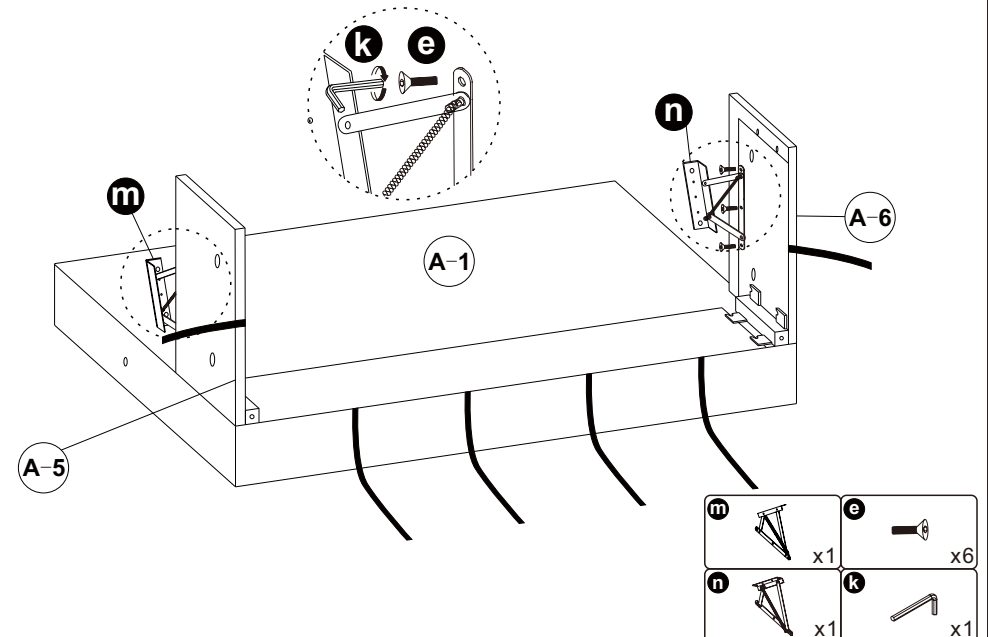

### STEP 5

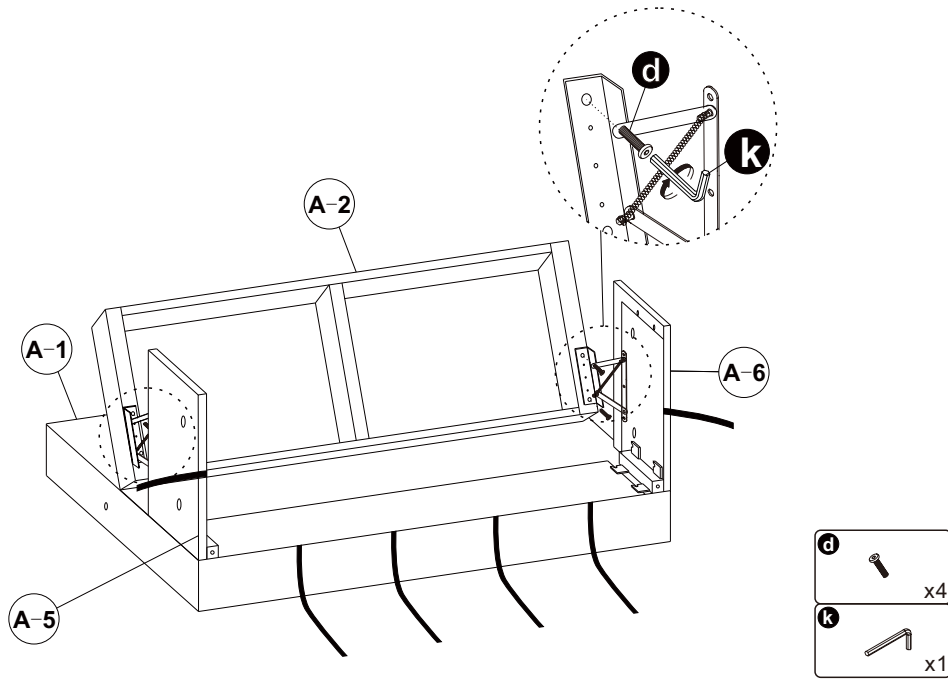

### STEP 6

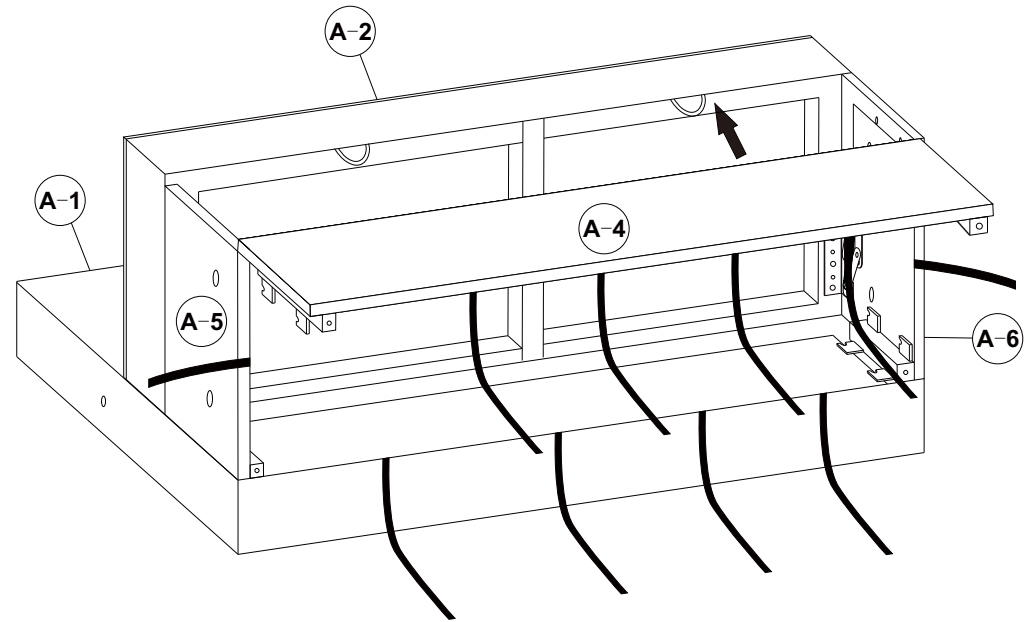

### STEP 7

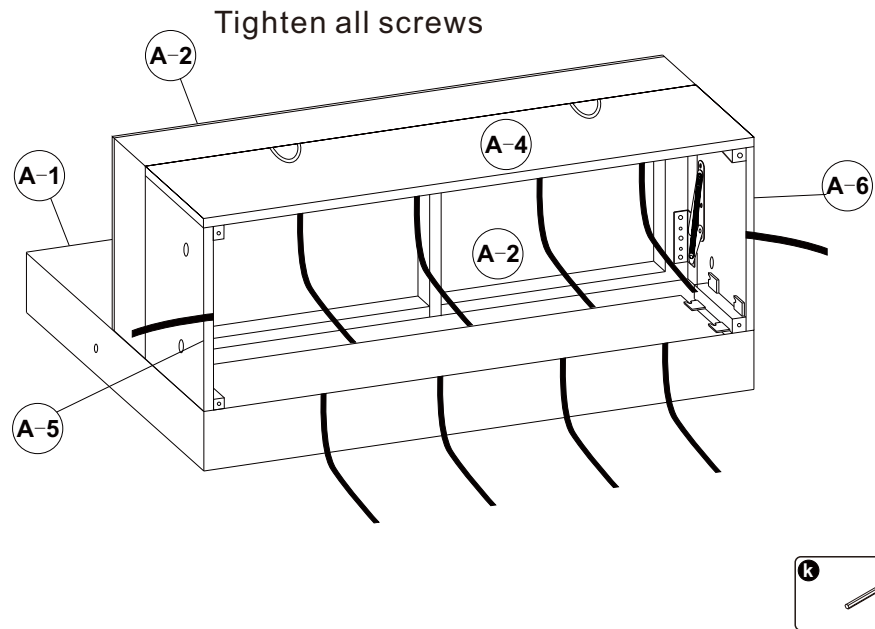

### STEP 8

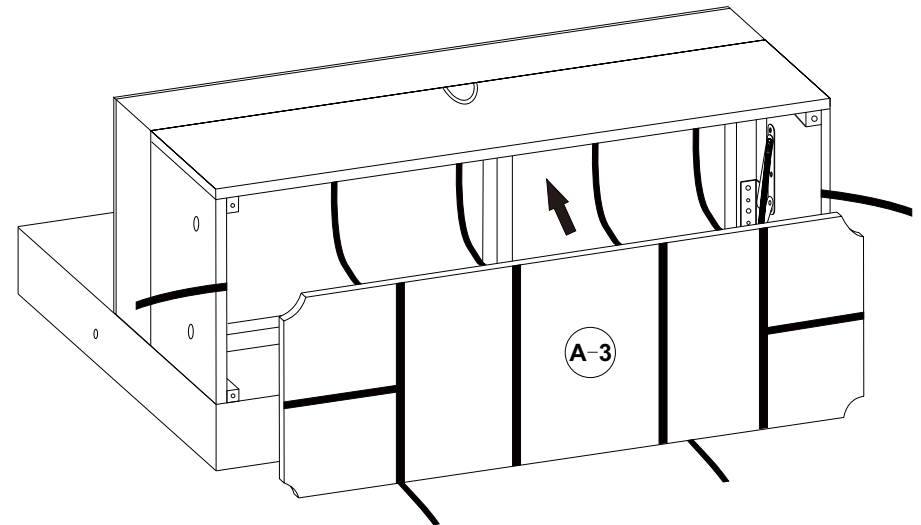



### STEP 9

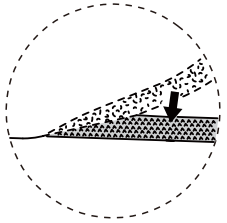

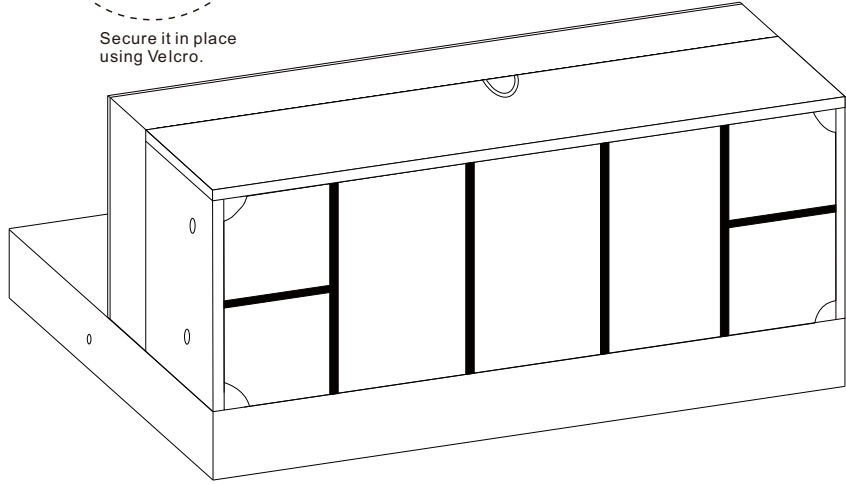

Secure it in place using Velcro.

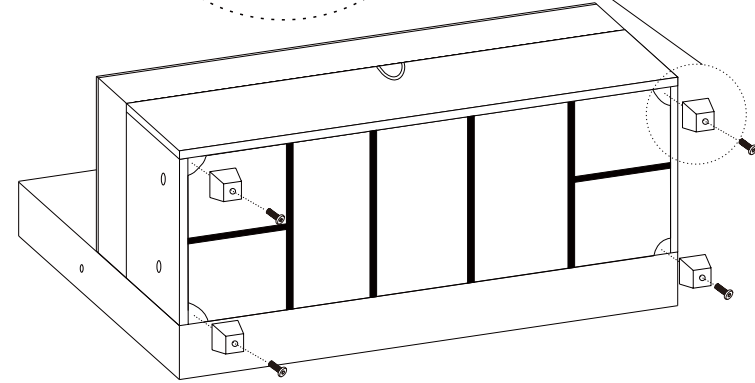
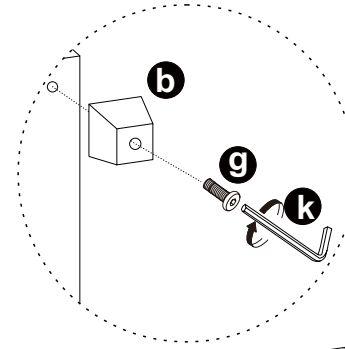

### STEP 10



- b**  x4
- g**  x4
- k**  x1

### STEP 11

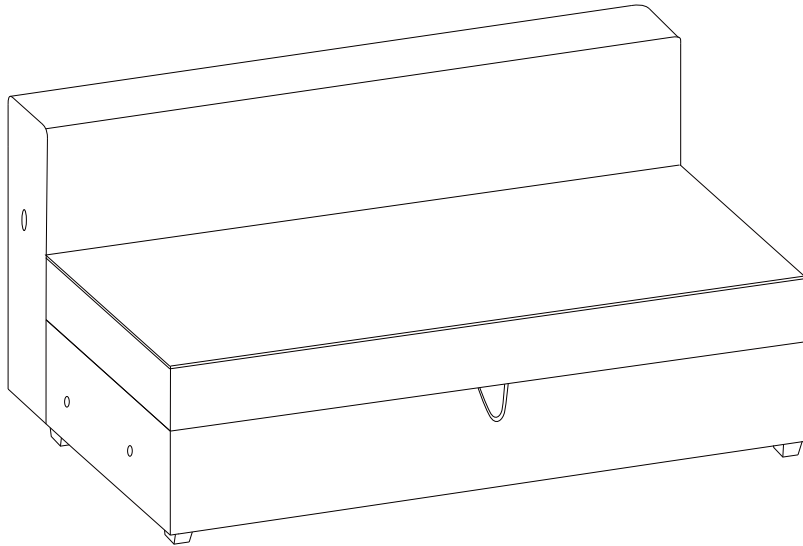

# ONE-SEAT

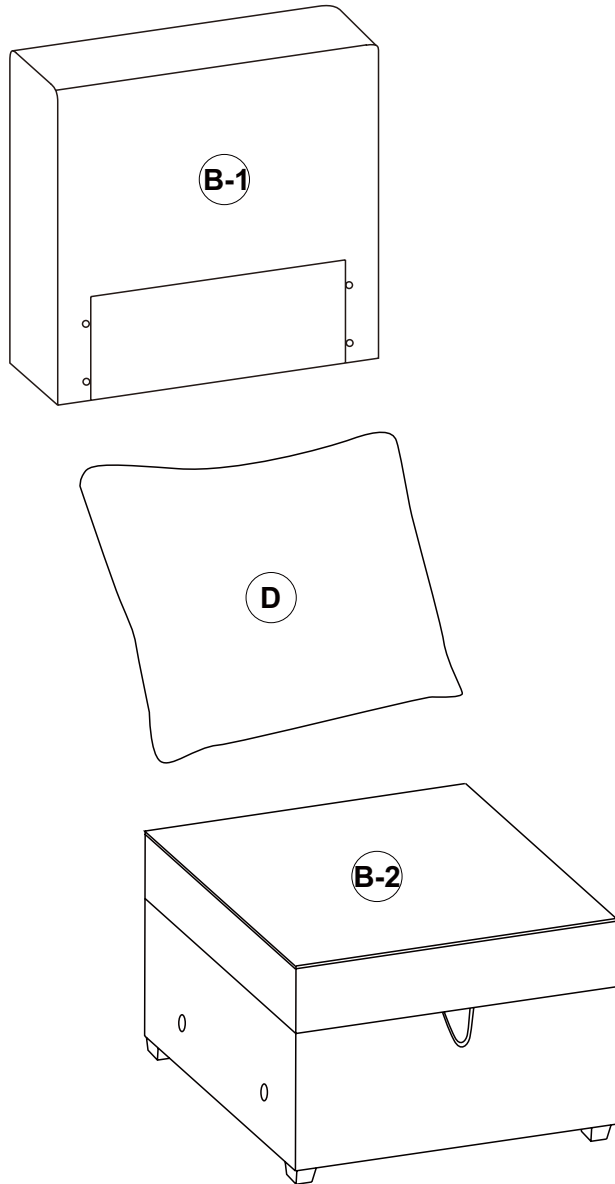

## Main structure accessories

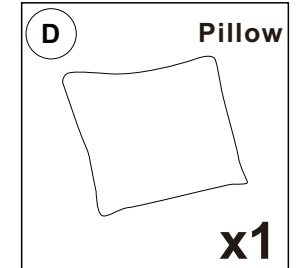
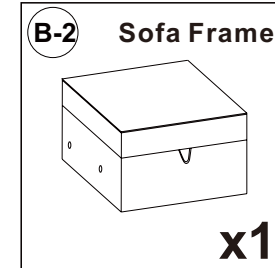
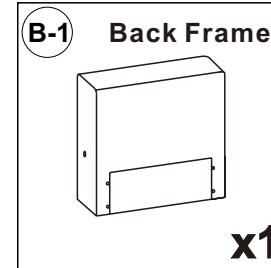

## Structural accessories

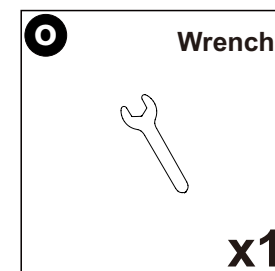
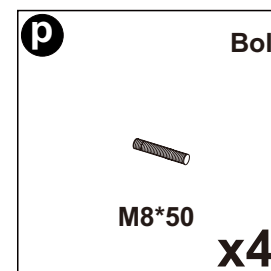
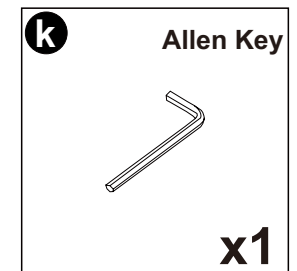
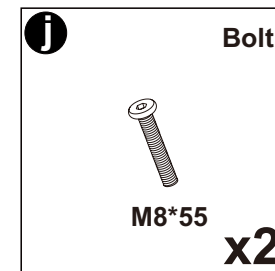
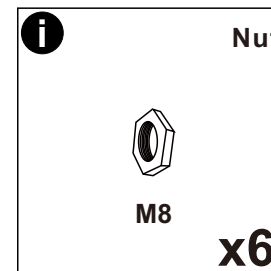
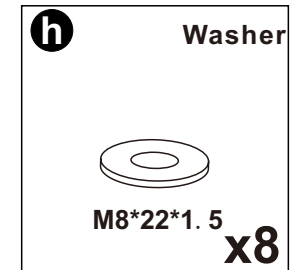
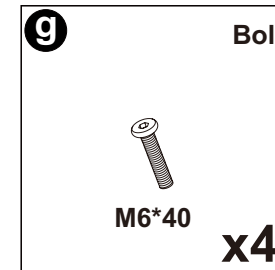
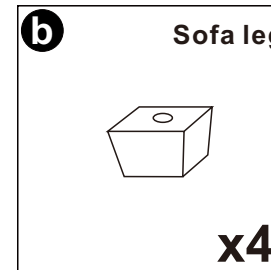

### STEP 1

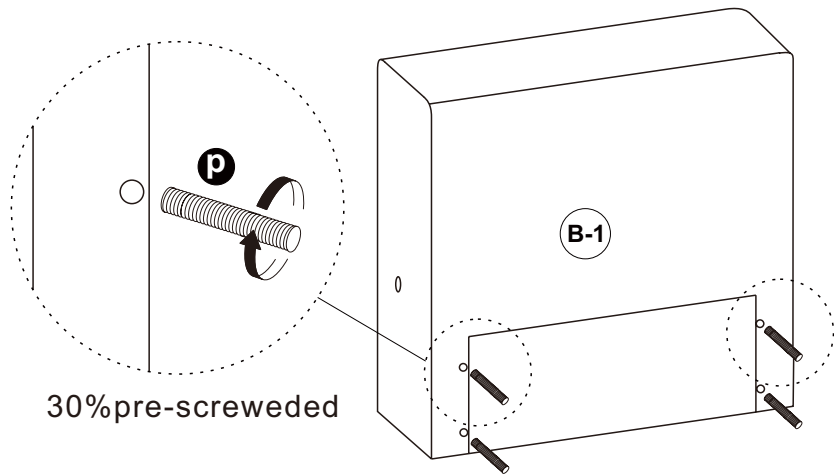

### STEP 2

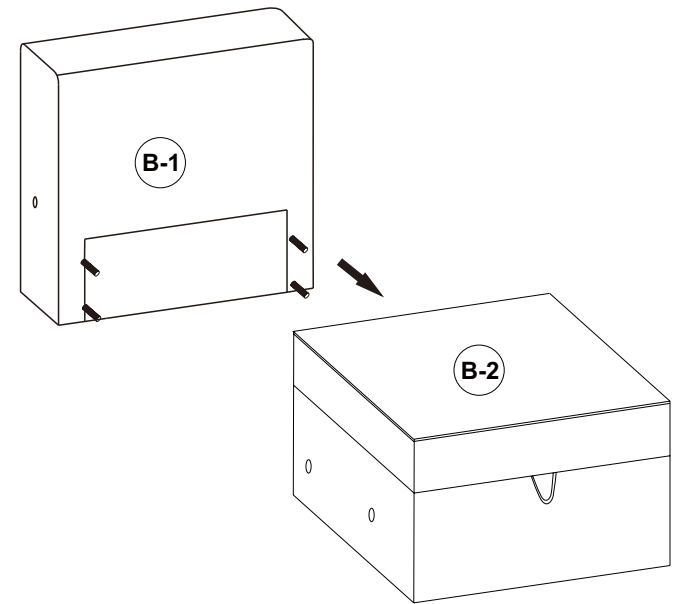

### STEP 3

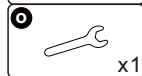
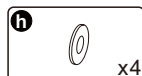
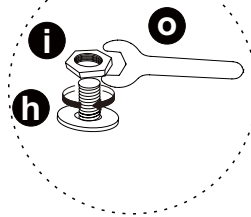
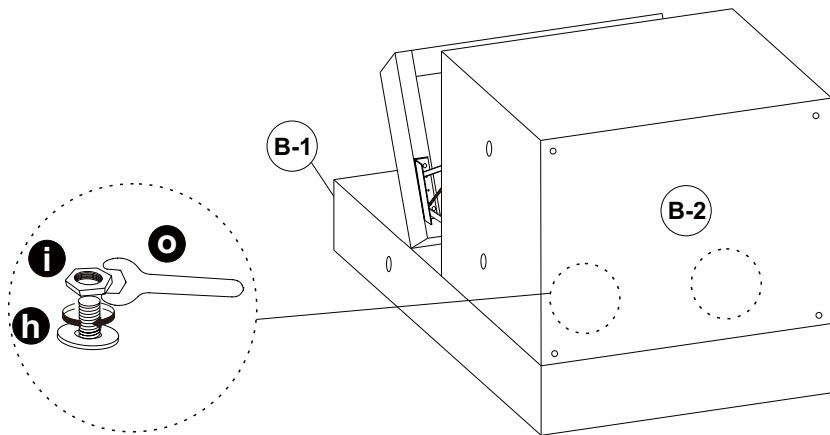

### STEP 4

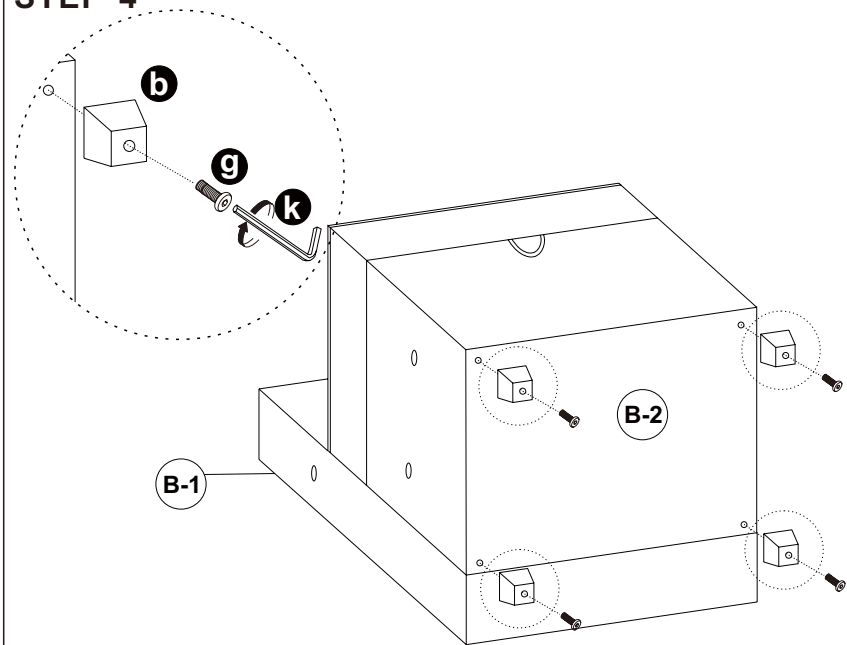

B-1

B-2

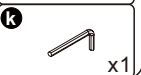
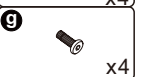
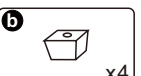

**STEP 5**

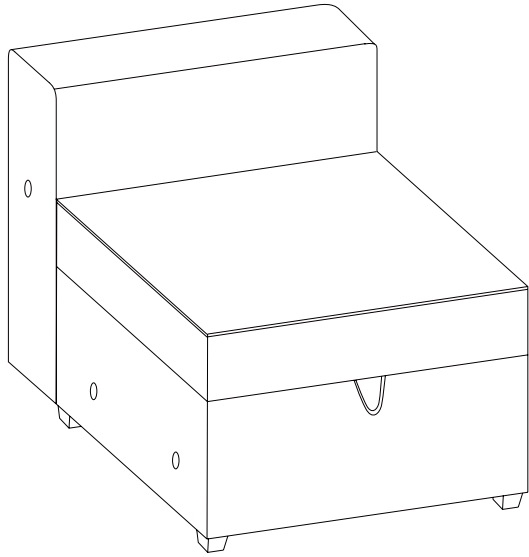

# Ottoman

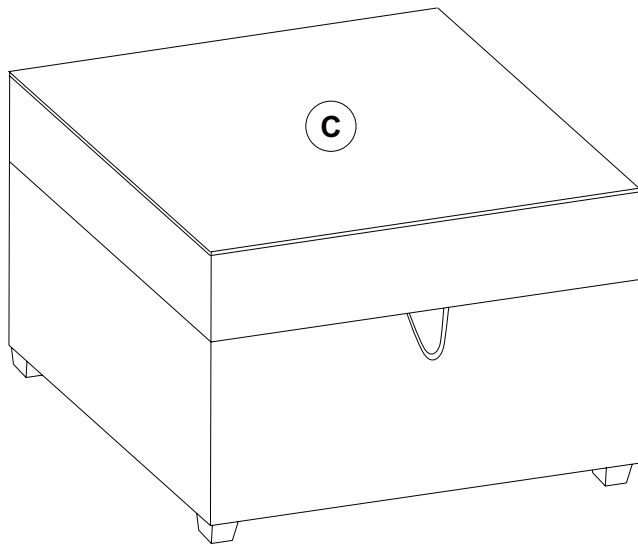

## Main structure accessories

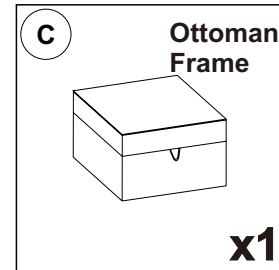

## Structural accessories

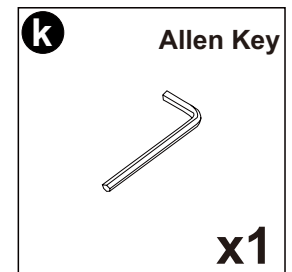
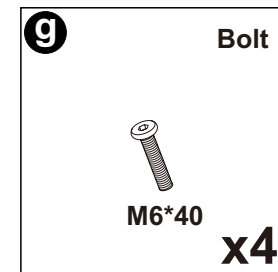
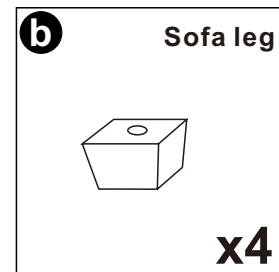

## STEP 1

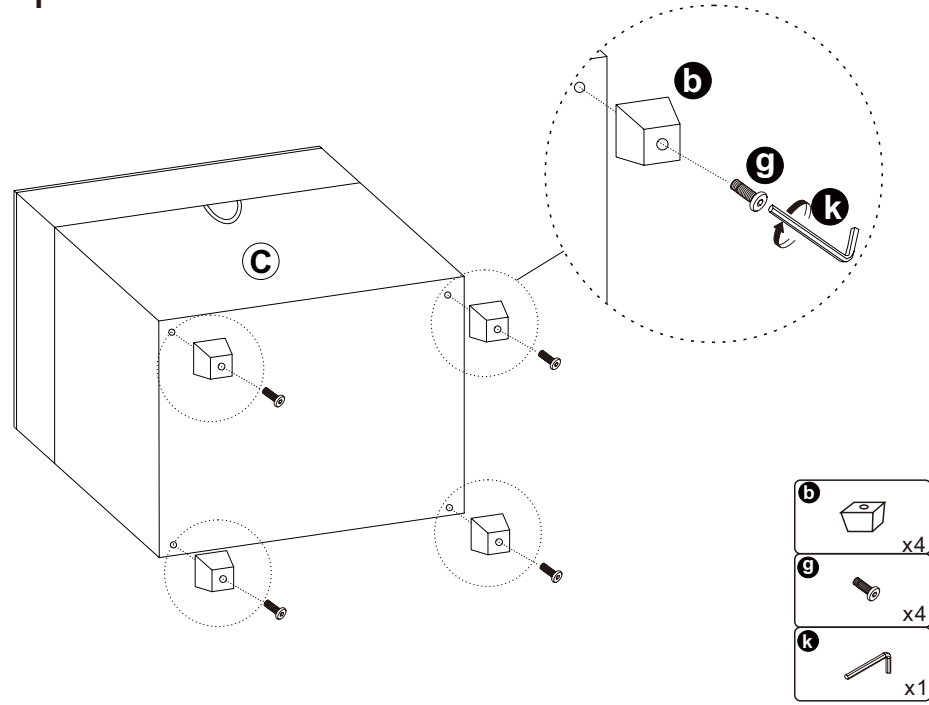

## STEP 2

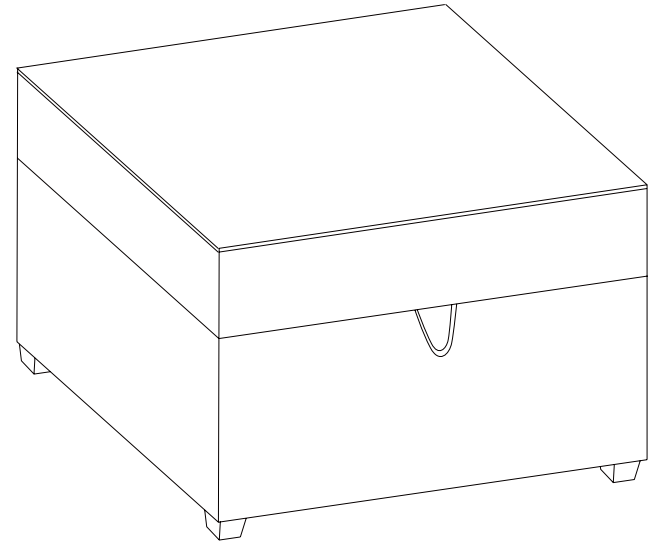

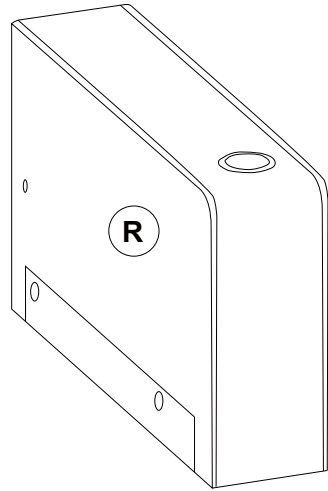
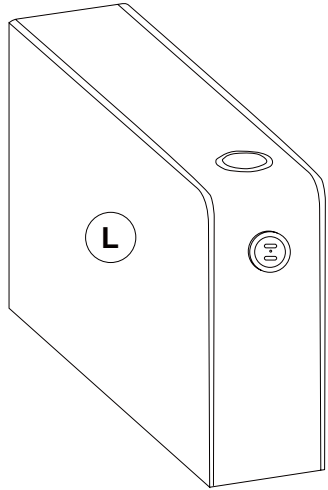
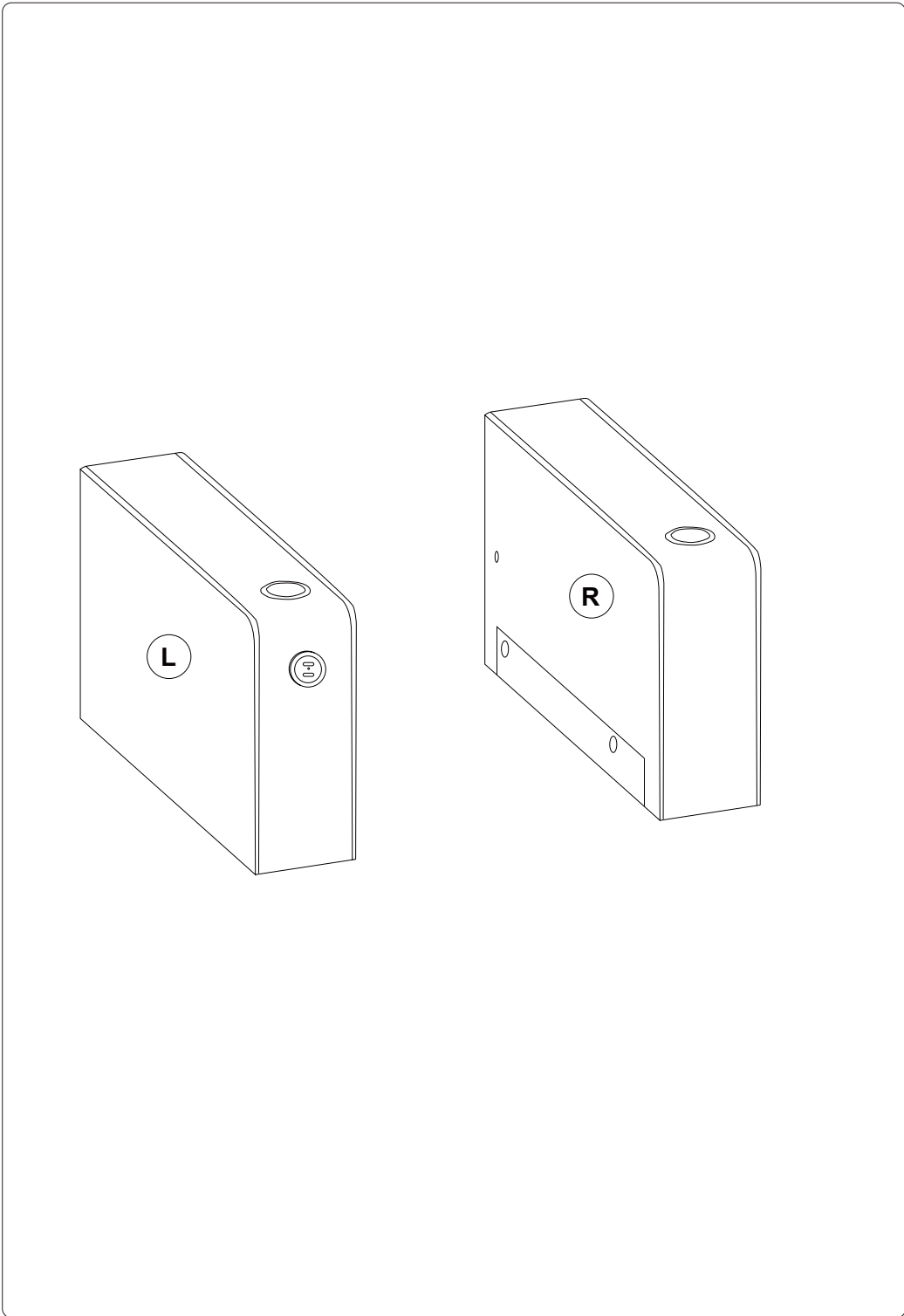

# Main structure accessories

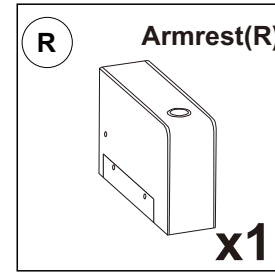
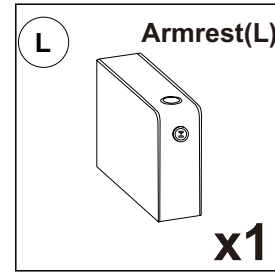

# Structural accessories

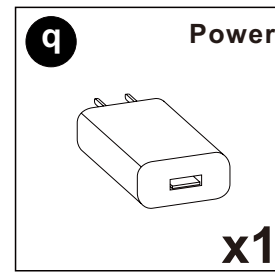
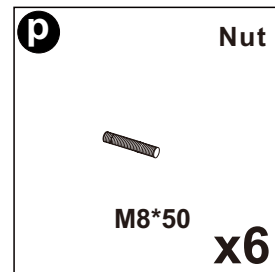
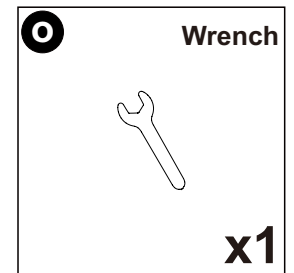
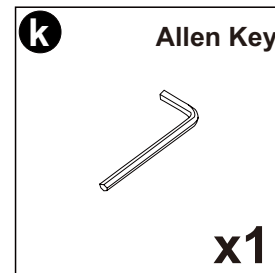
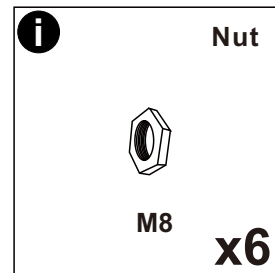
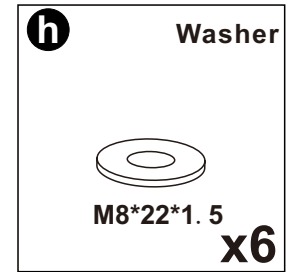
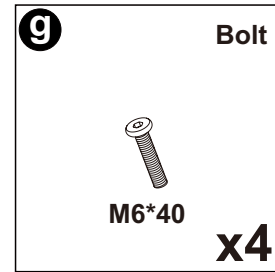
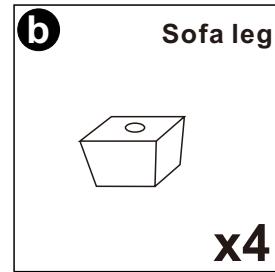

Attention! Additional products need to be purchased before connecting.

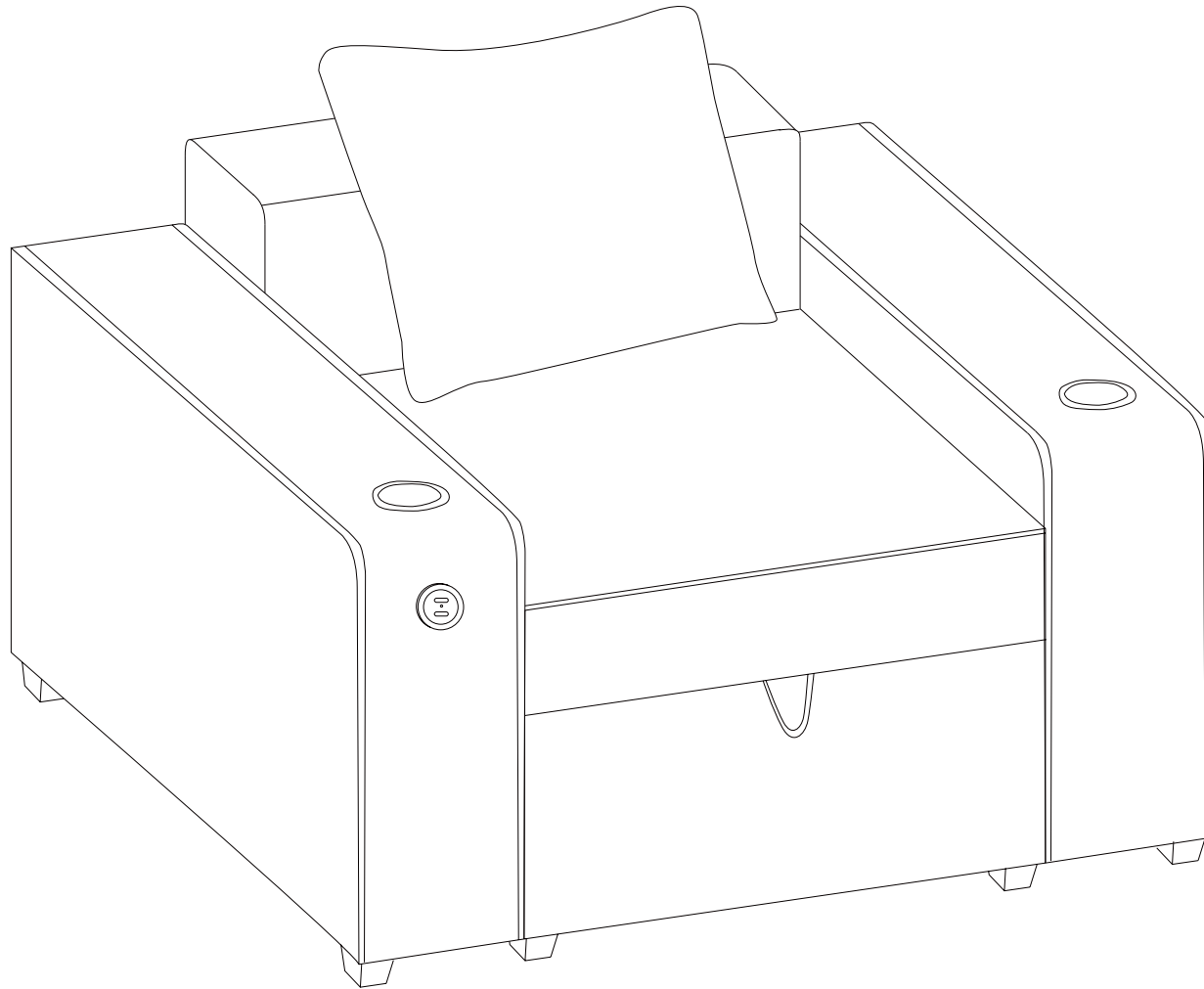



### STEP 1

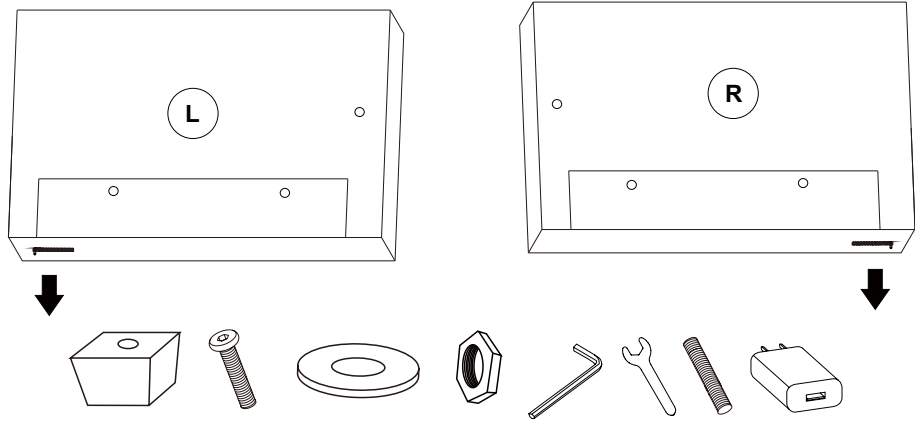

Take b, g, h, i, k, o, p and q out of the bottom of L and R

### STEP 2

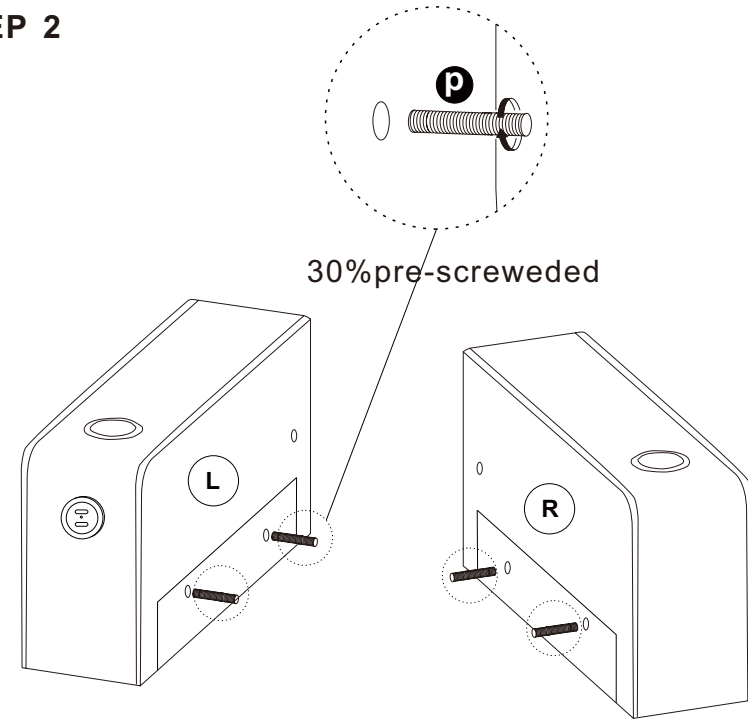

### STEP 3

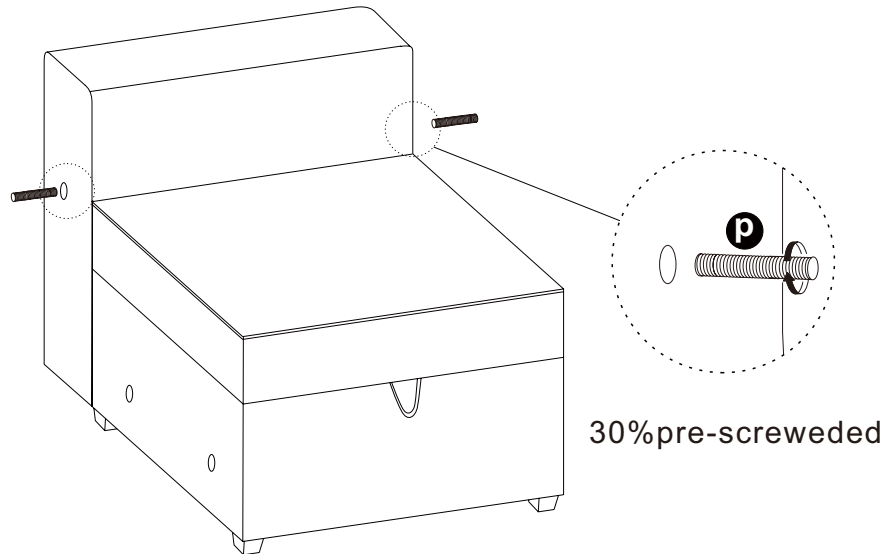

### STEP 4

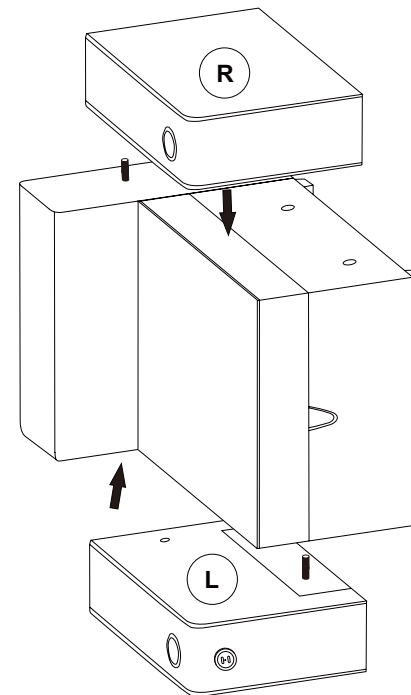

### STEP 5

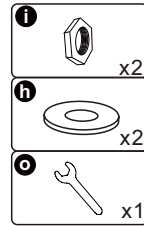
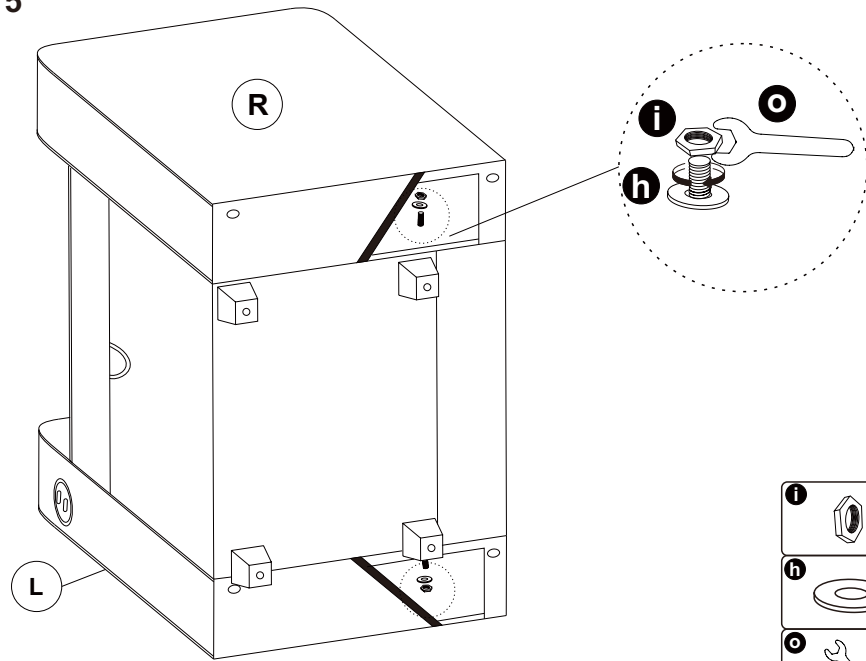

All the components P should be locked with components i.

### STEP 6

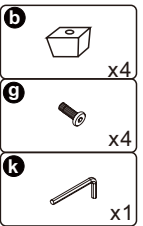
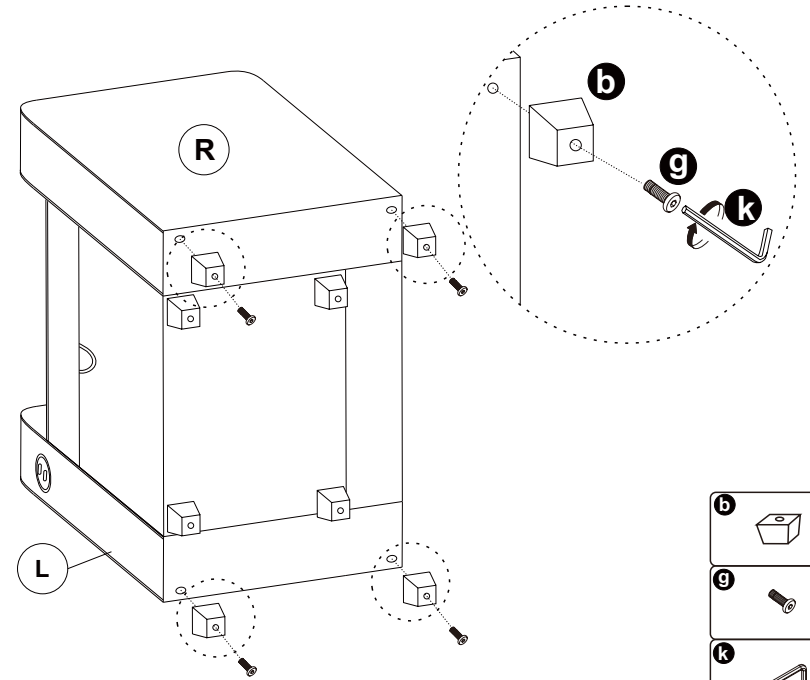

### STEP 7

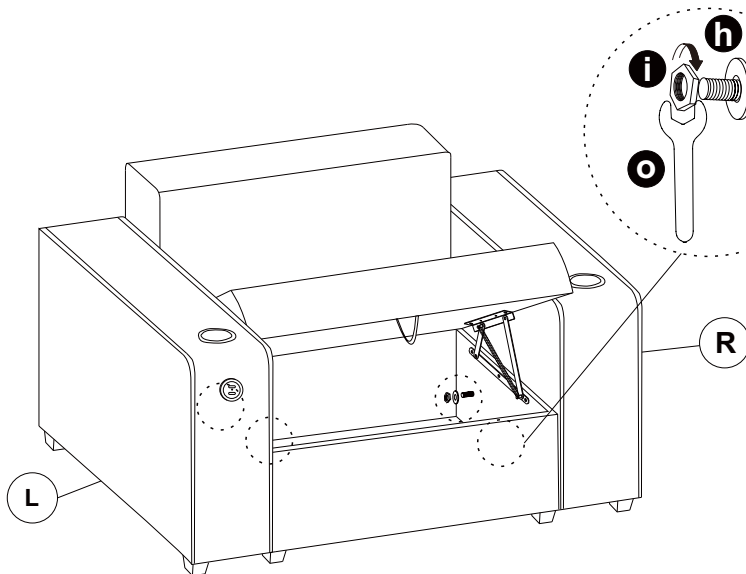

### STEP 8

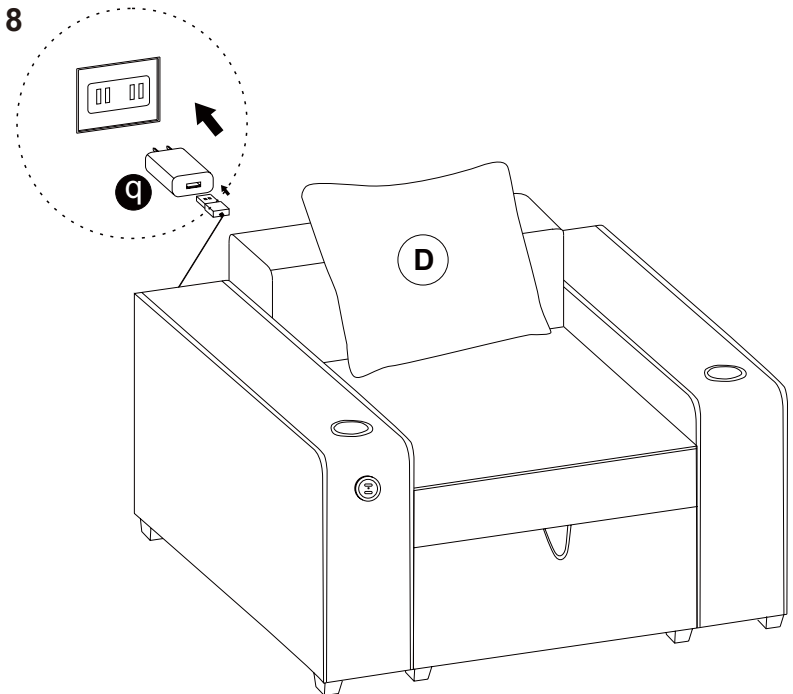

Attention! Additional products need to be purchased before connecting.

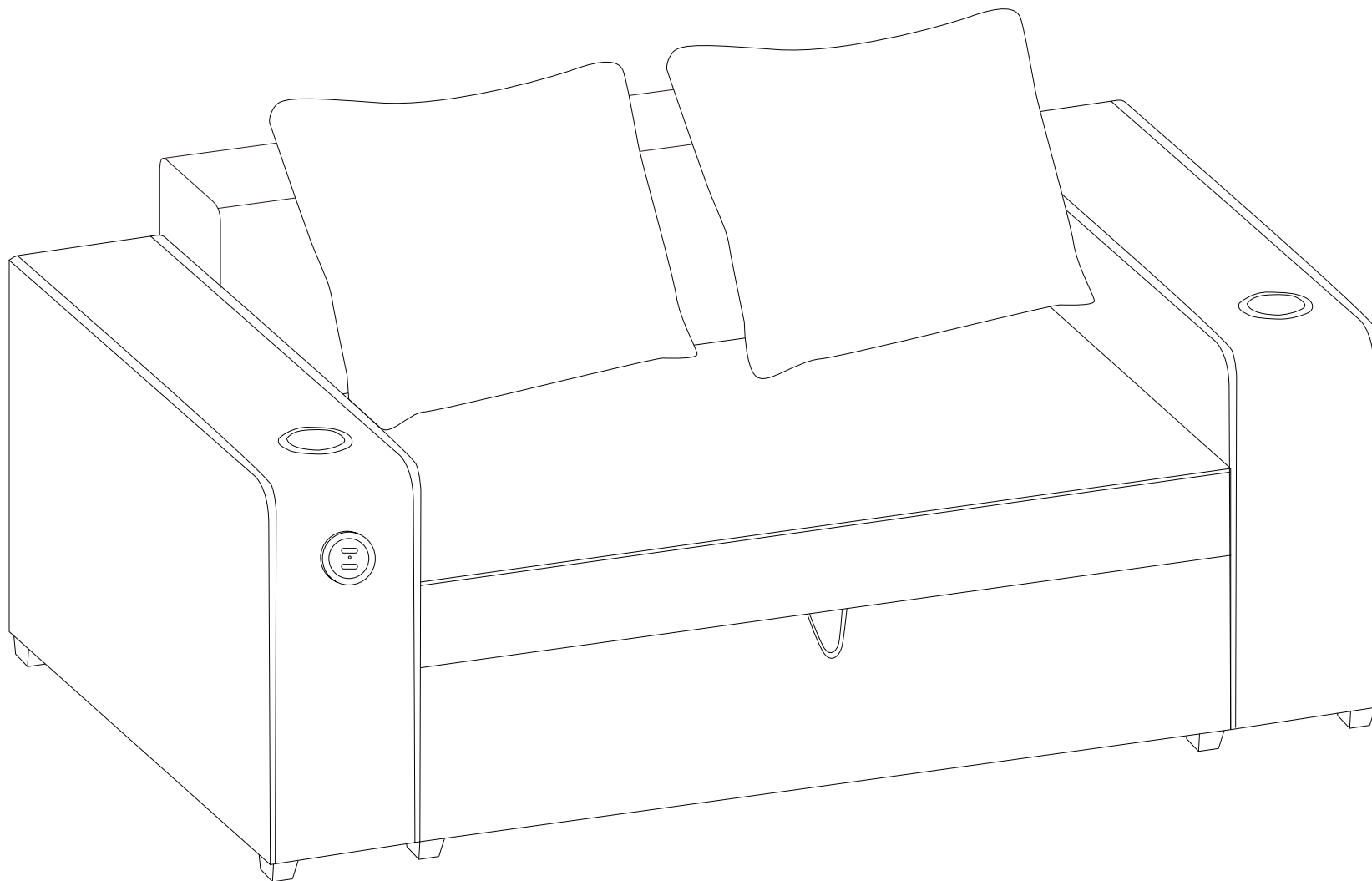

### STEP 1

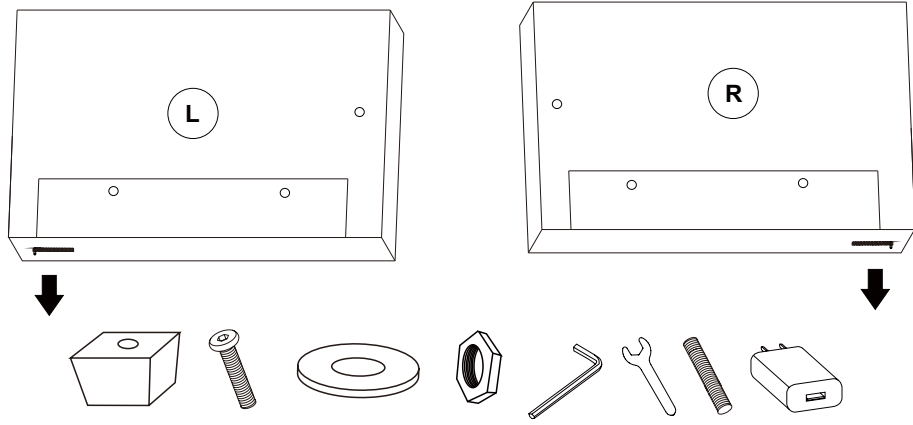

Take b, g, h, i, k, o, p and q out of the bottom of L and R

### STEP 2

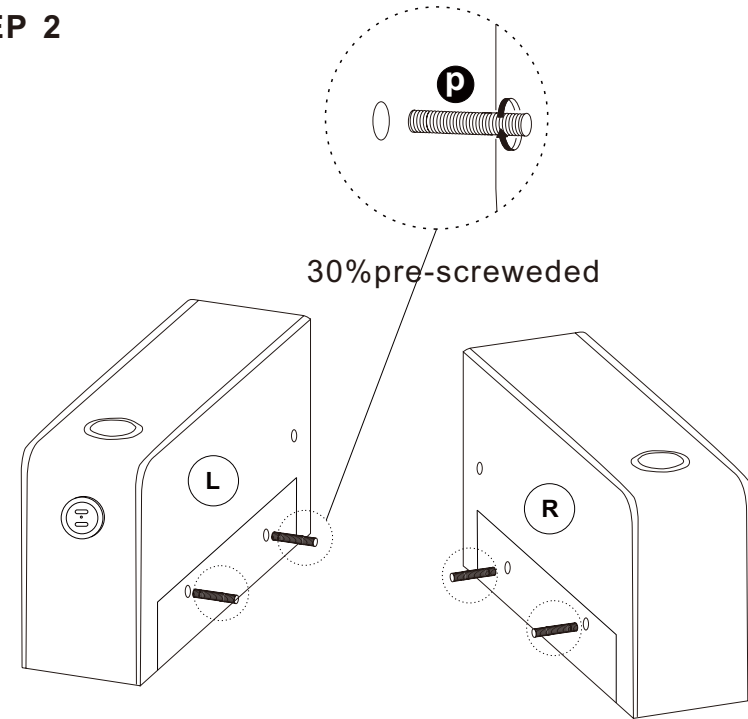

### STEP 3

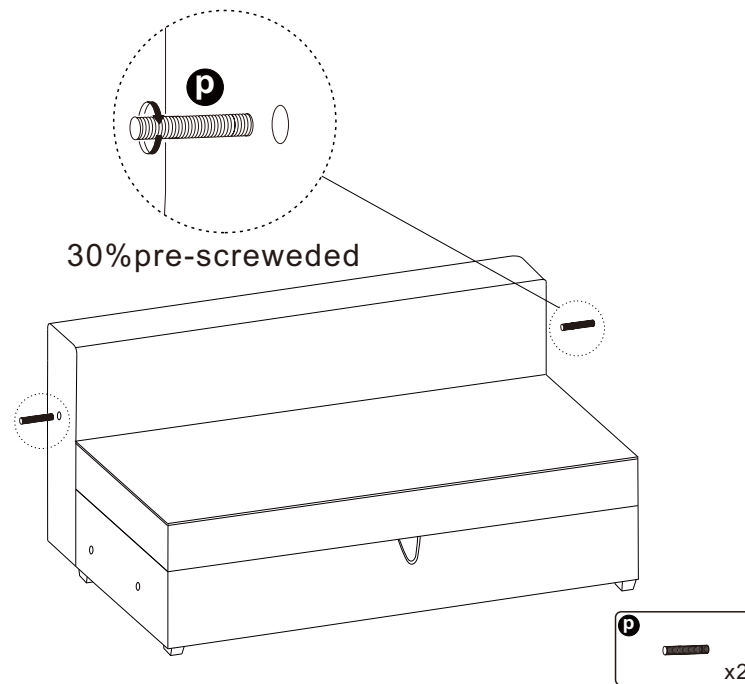

### STEP 4

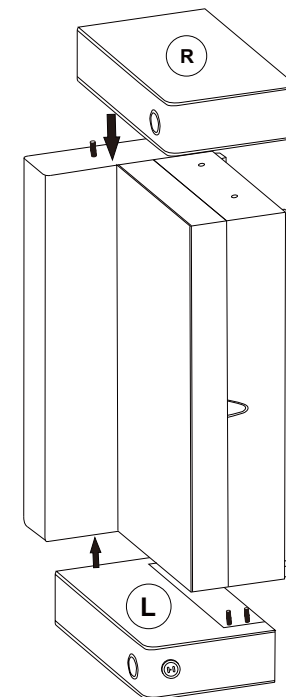

### STEP 5

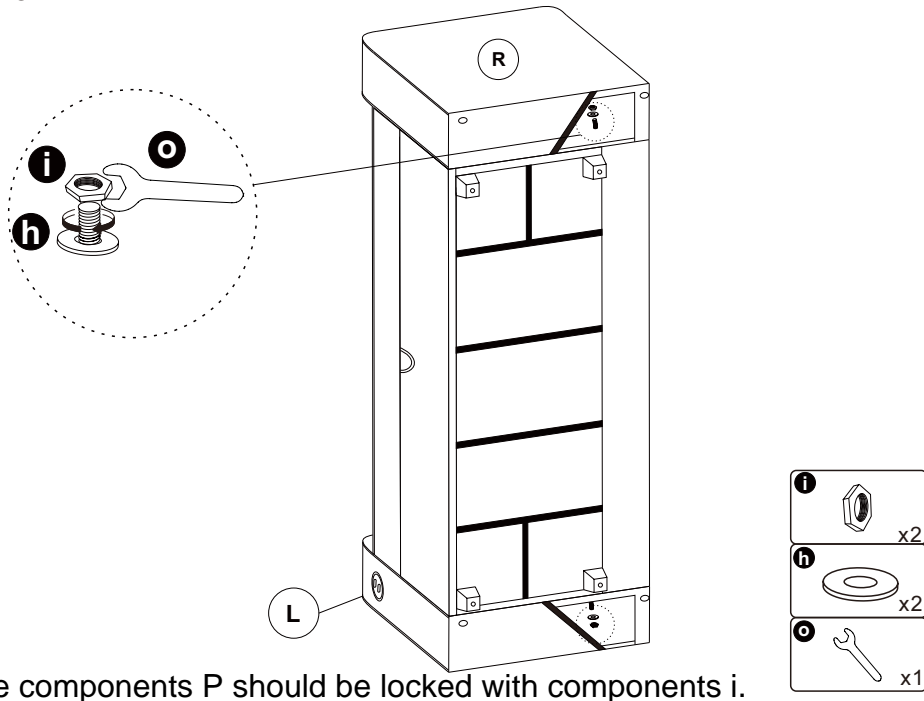

### STEP 6

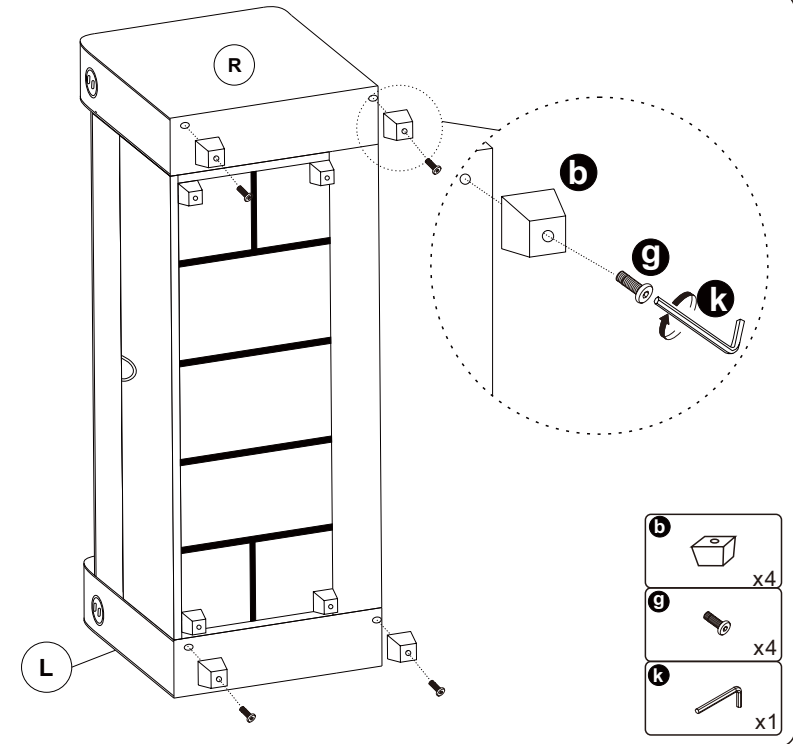

### STEP 7

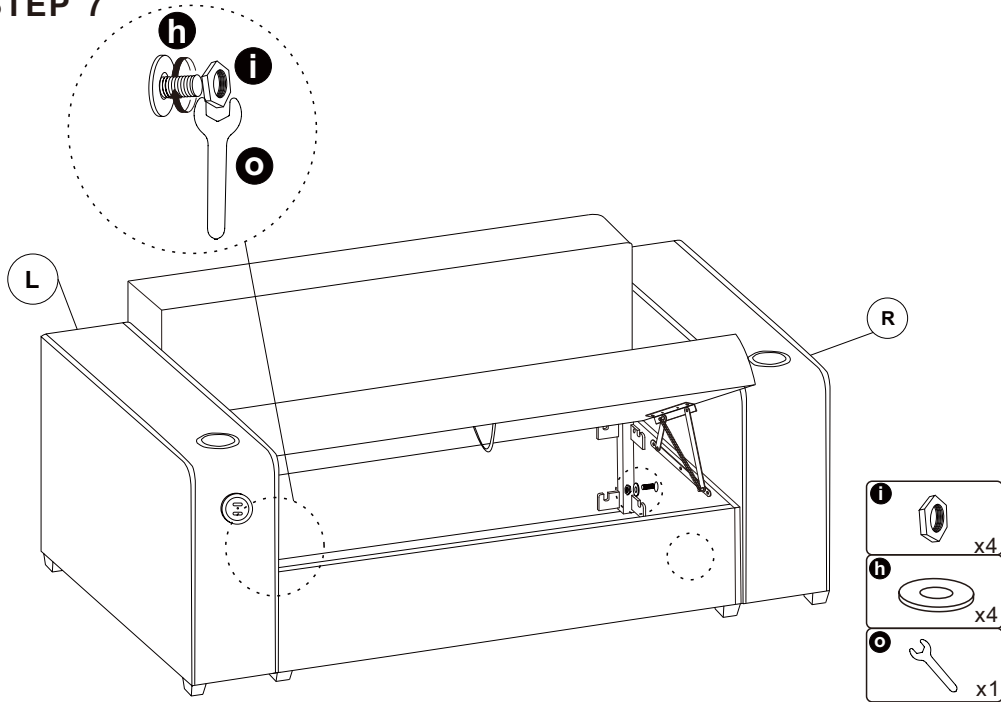

### STEP 8

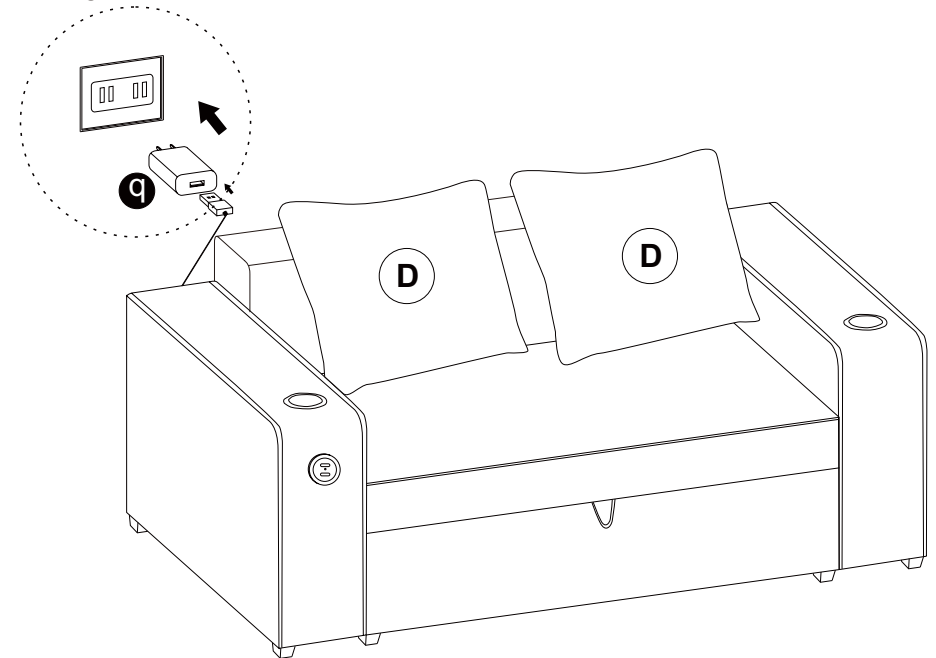

Attention! Additional products need to be purchased before connecting.

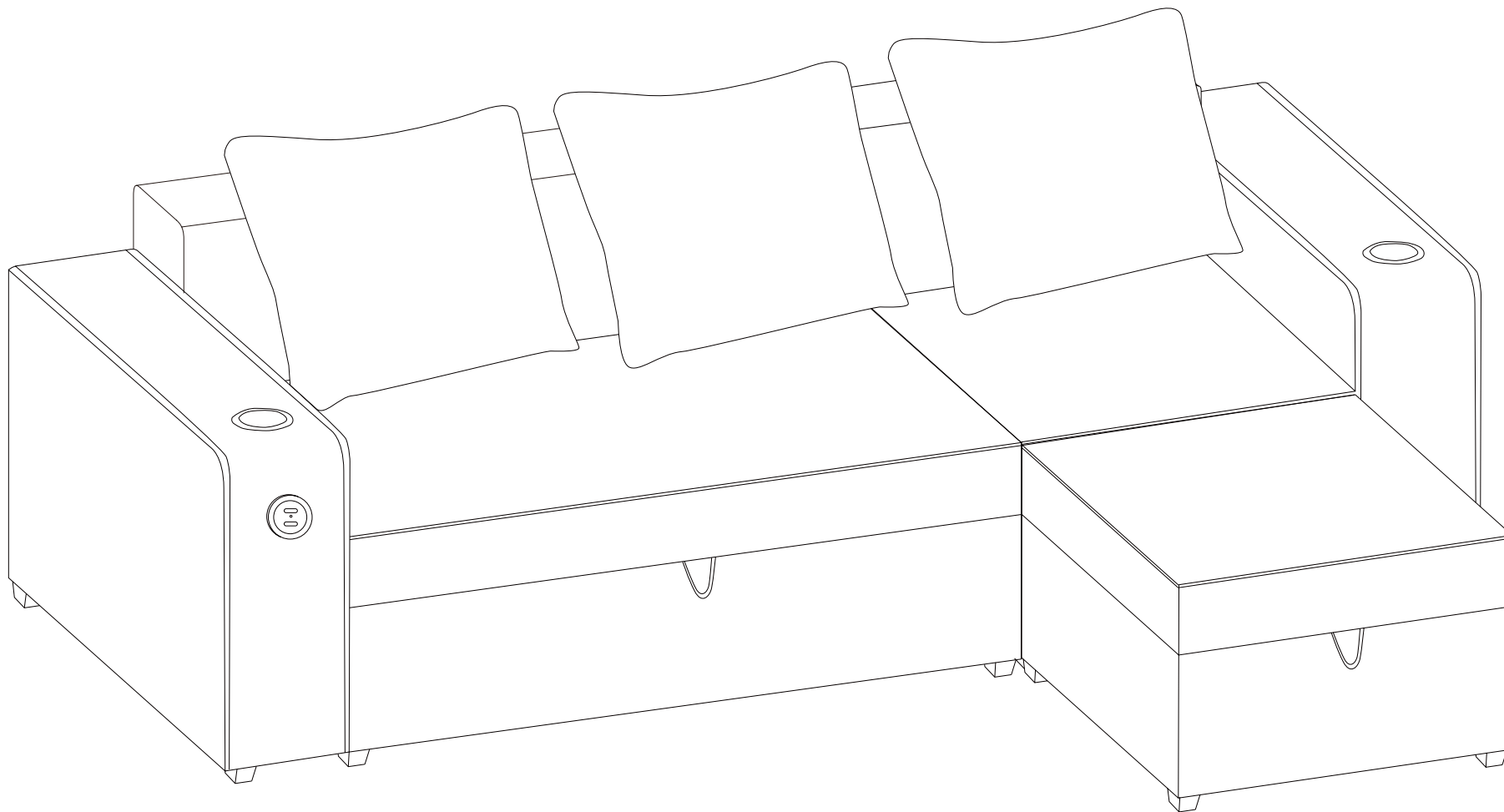

### STEP 1

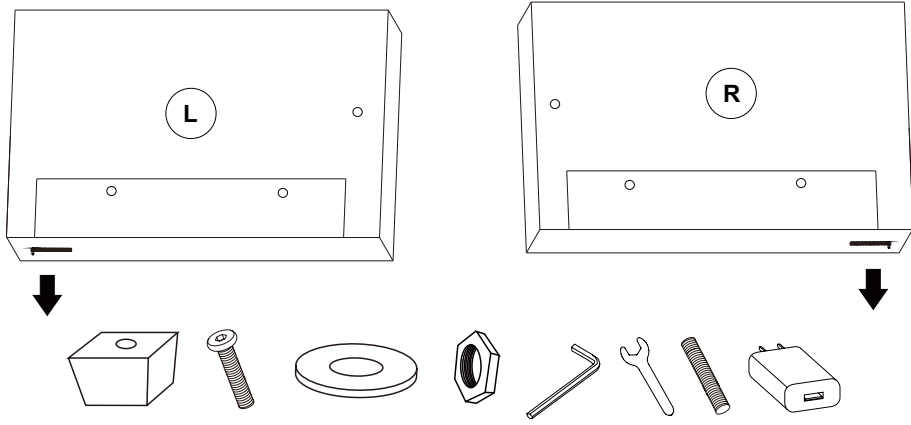

Take b, g, h, i, k, o, p and q out of the bottom of L and R

### STEP 2

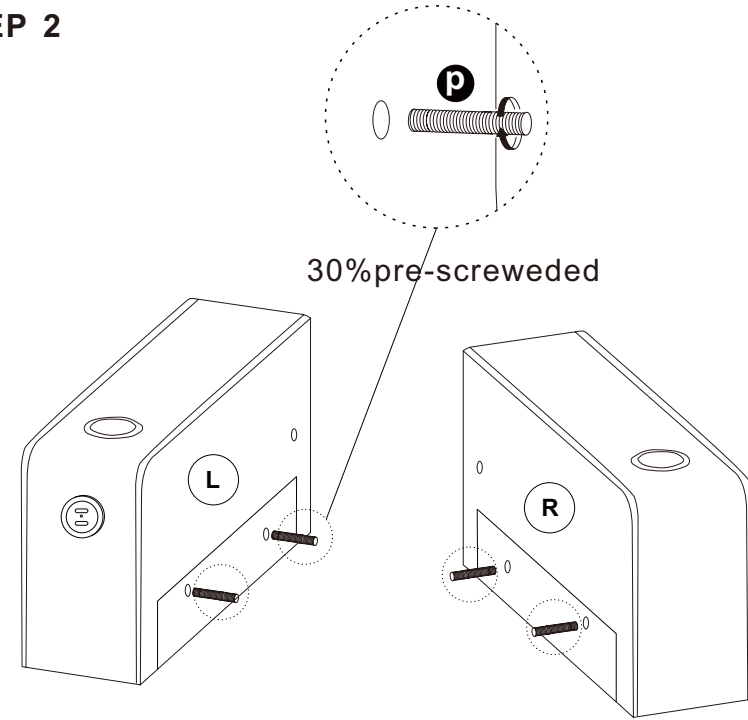

### STEP 3

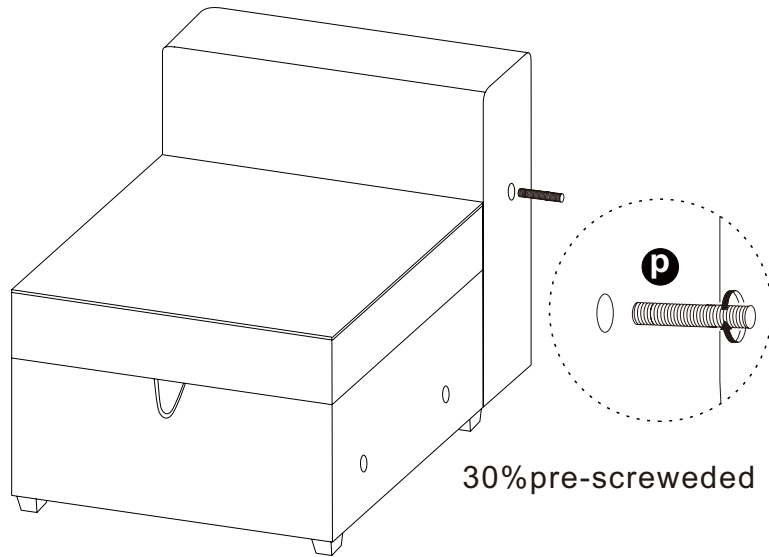

### STEP 4

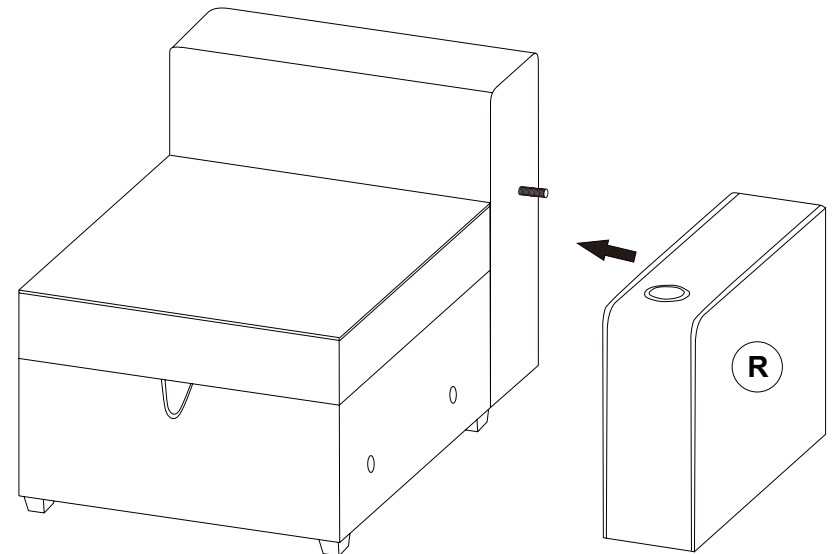

### STEP 5

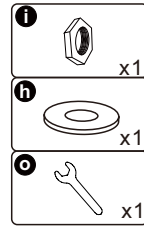
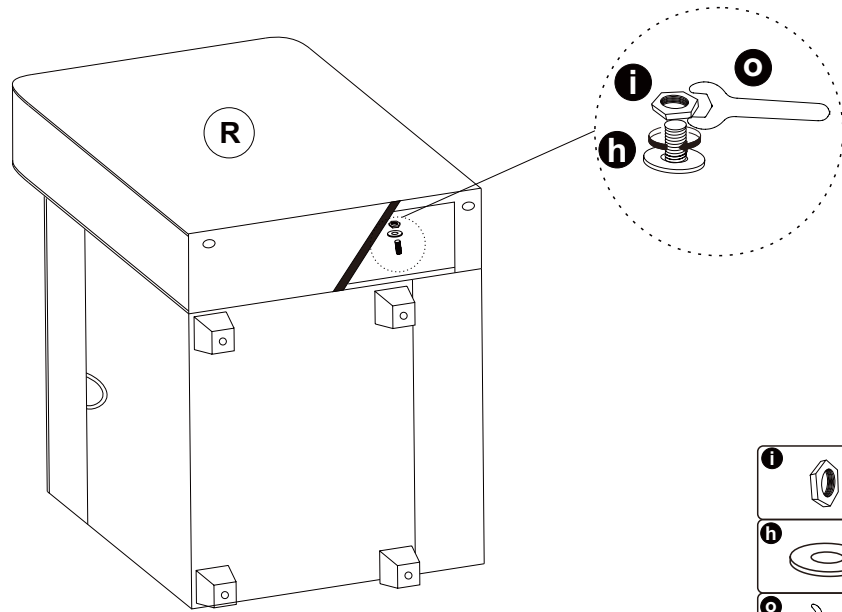

All the components P should be locked with components i.

### STEP 6

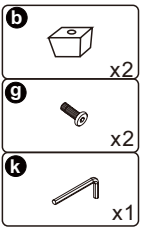
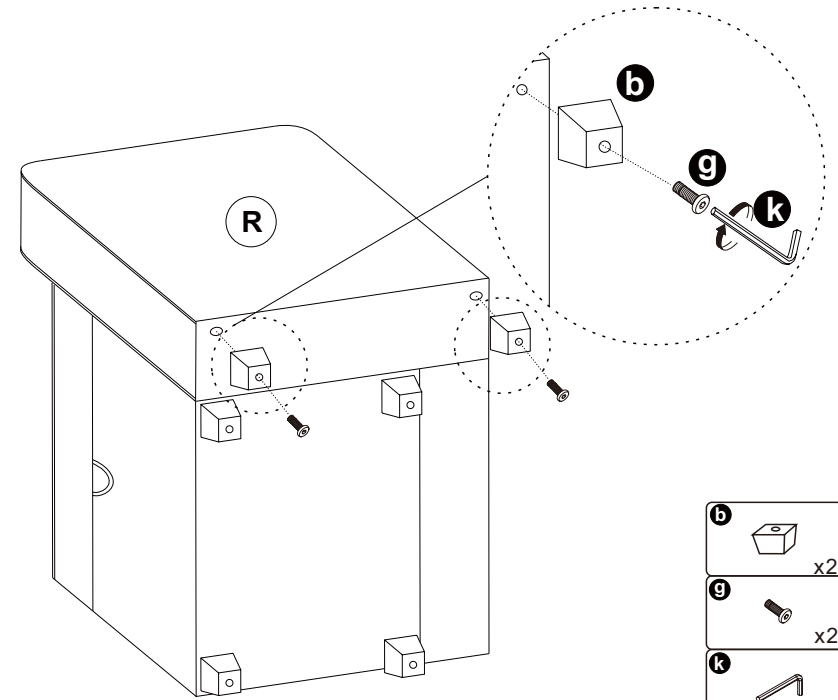

### STEP 7

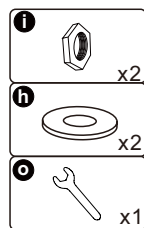
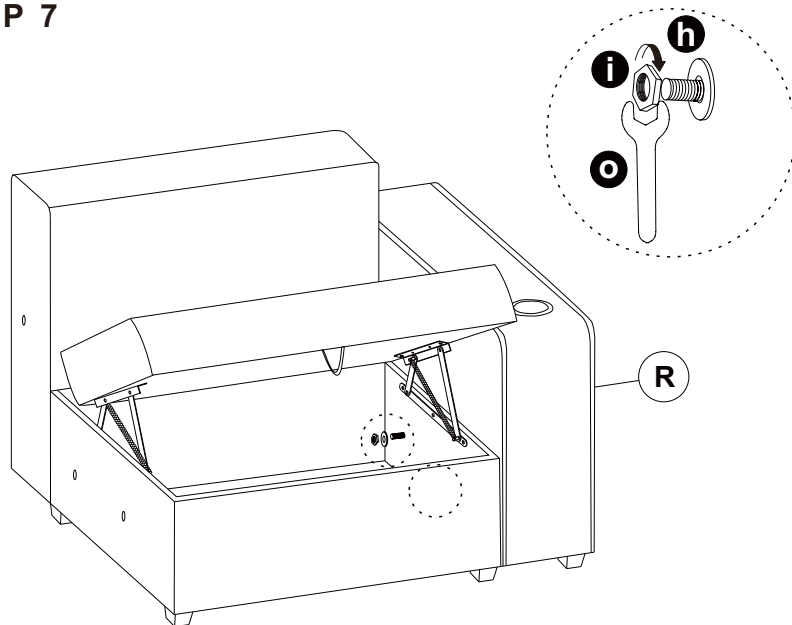

### STEP 8

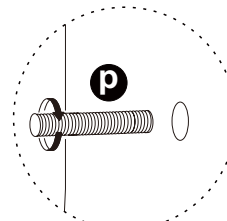

30% pre-screwed

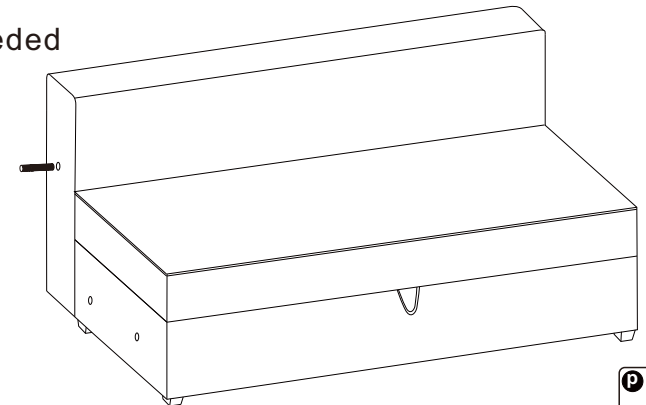



### STEP 9

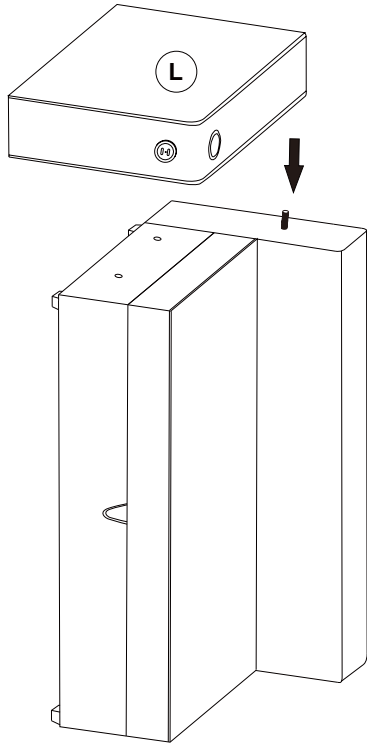

### STEP 10

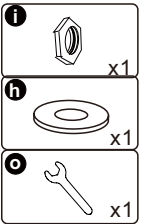
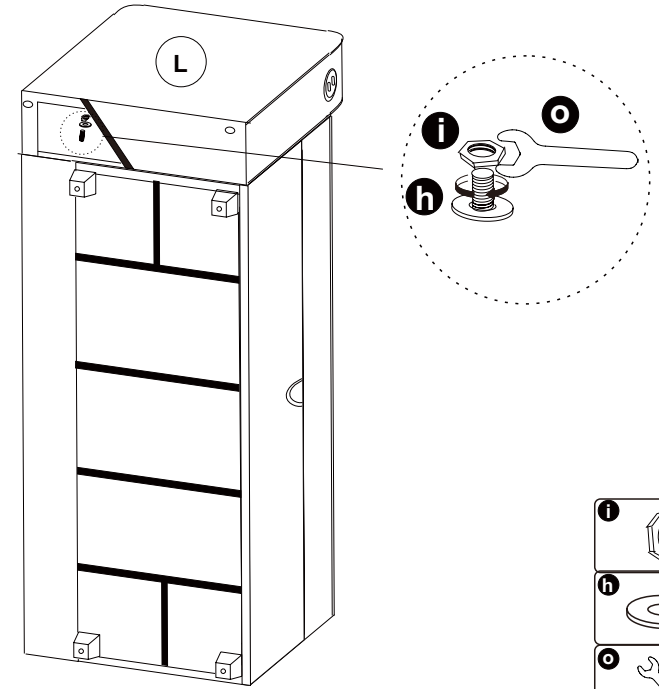

All the components P should be locked with components i.

### STEP 11

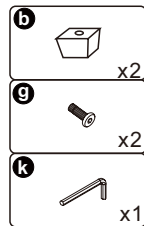
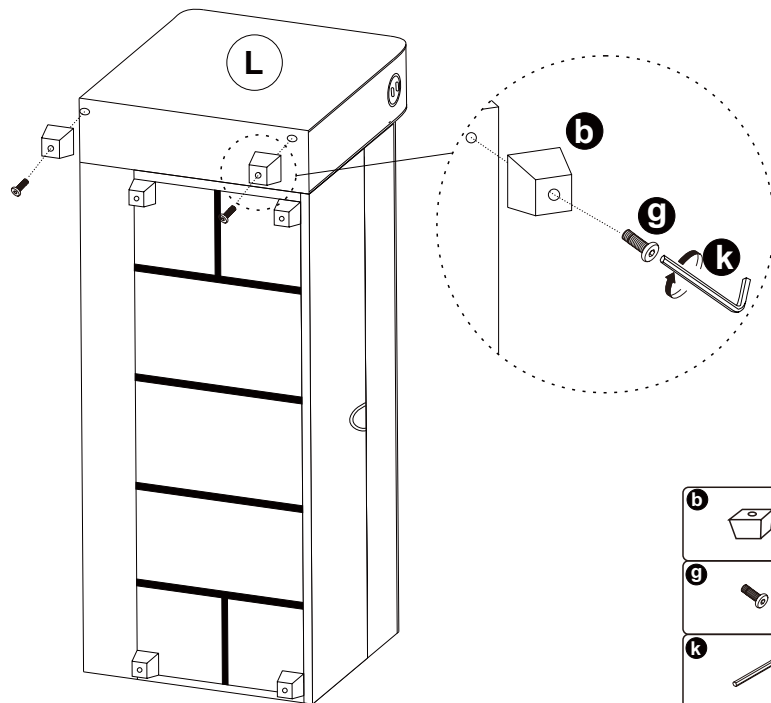

### STEP 12

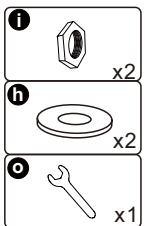
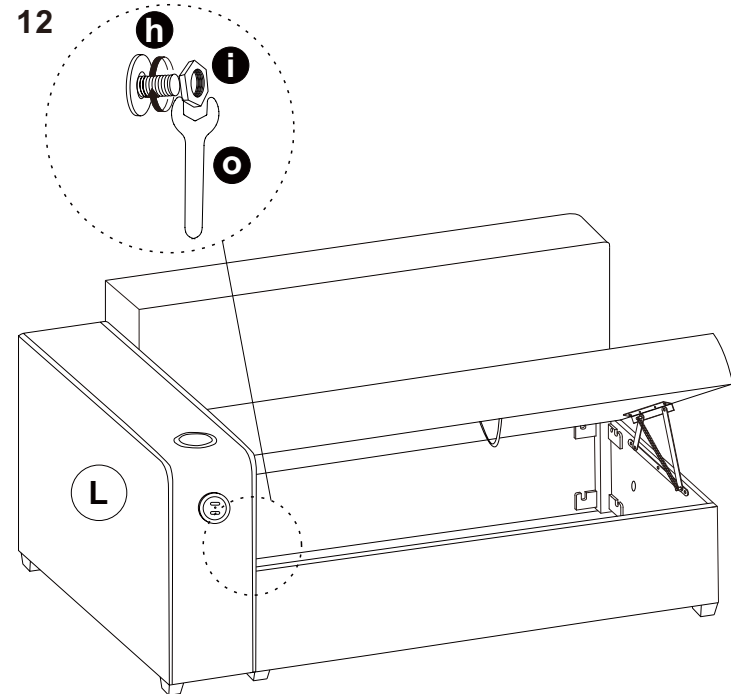

### STEP 13

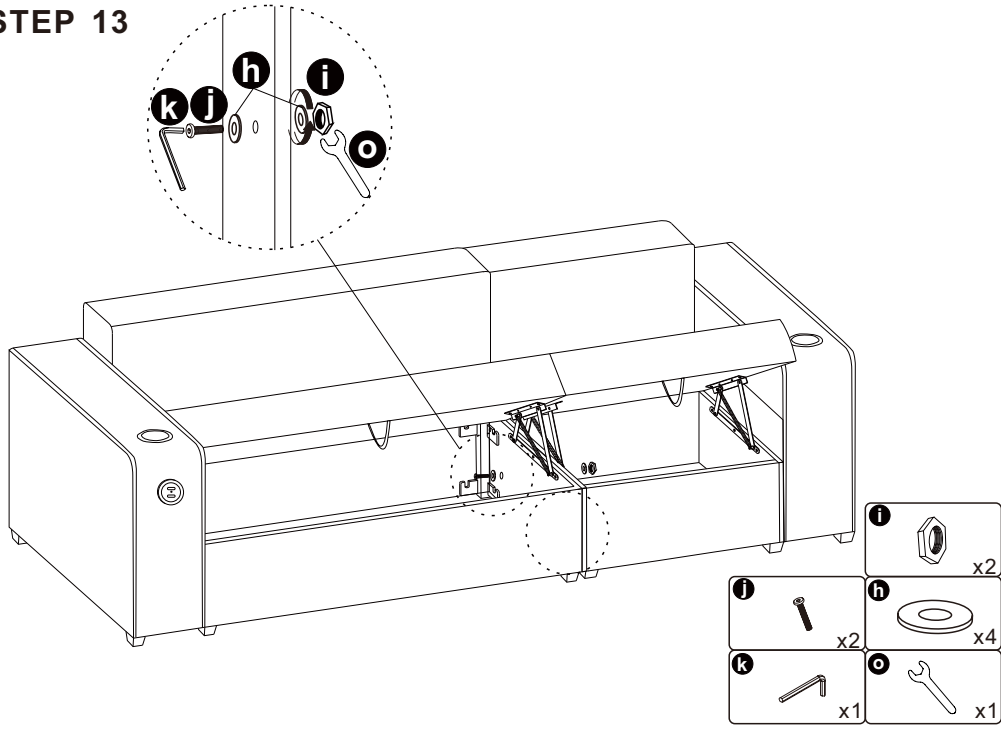

### STEP 14

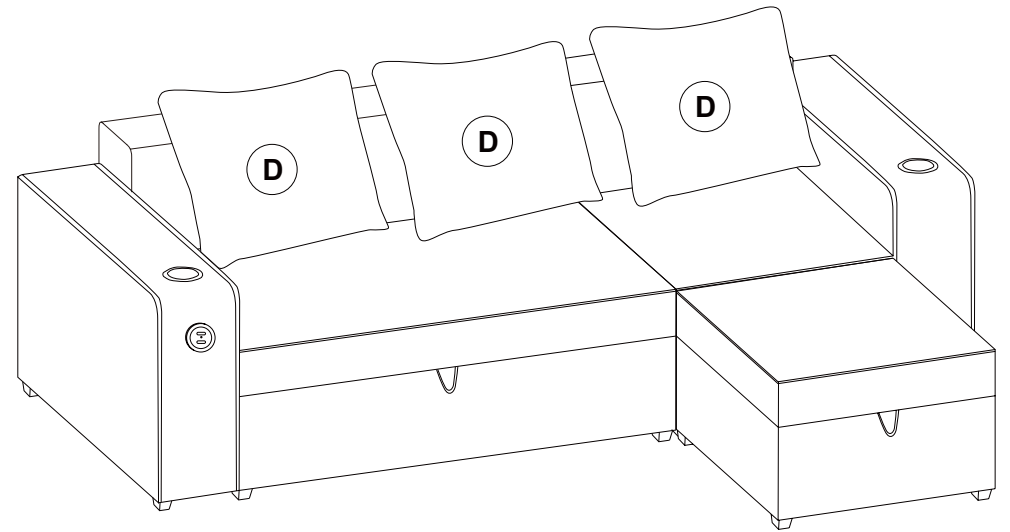

### STEP 15

