

OFFICE CHAIR

Assembly Instruction



Any question please feel free to contact us ;
support@amer-life.com TEL ; 901-347-2181
We will provide further assistance within 24 hours .

Dear Customers,

Thank you for purchasing our product. Please read this instruction manual carefully after receiving this product. It will help you assemble this product quickly, safely and correctly. You can keep this manual for future reference.

CHAIR

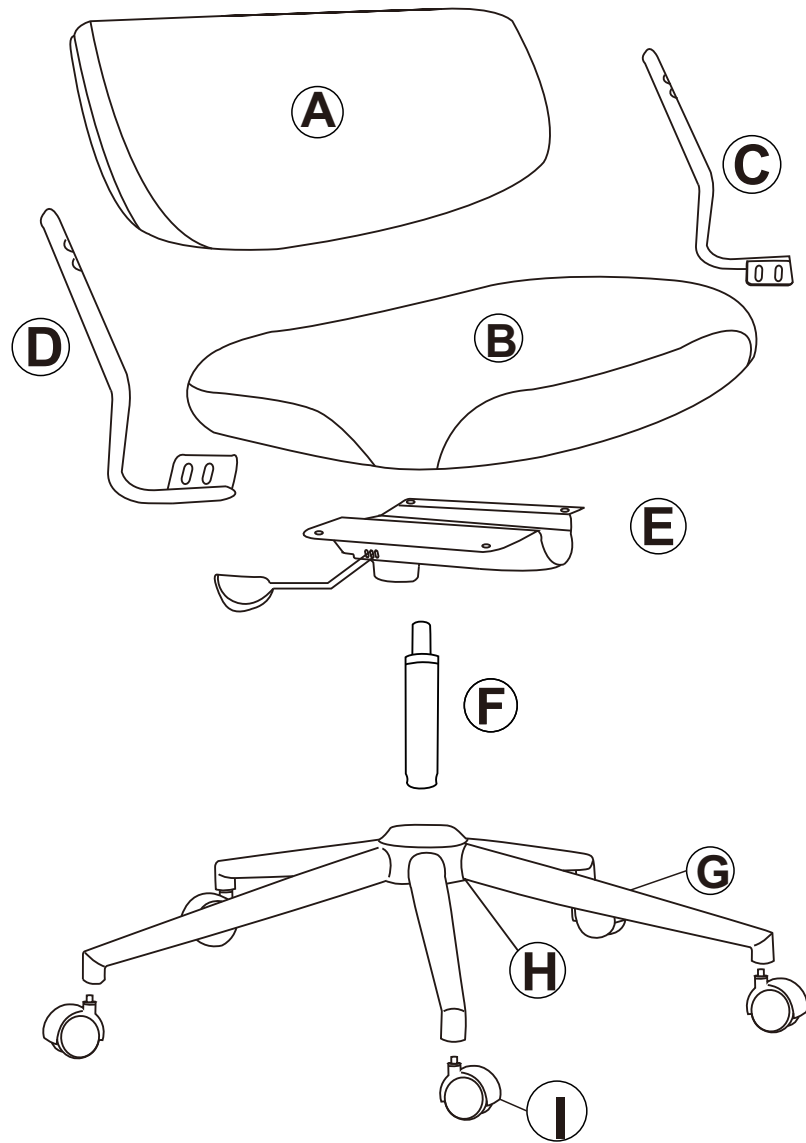

Hardware parts

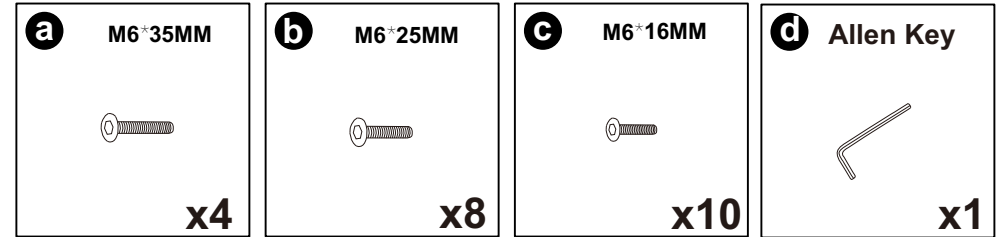

Main structure accessories

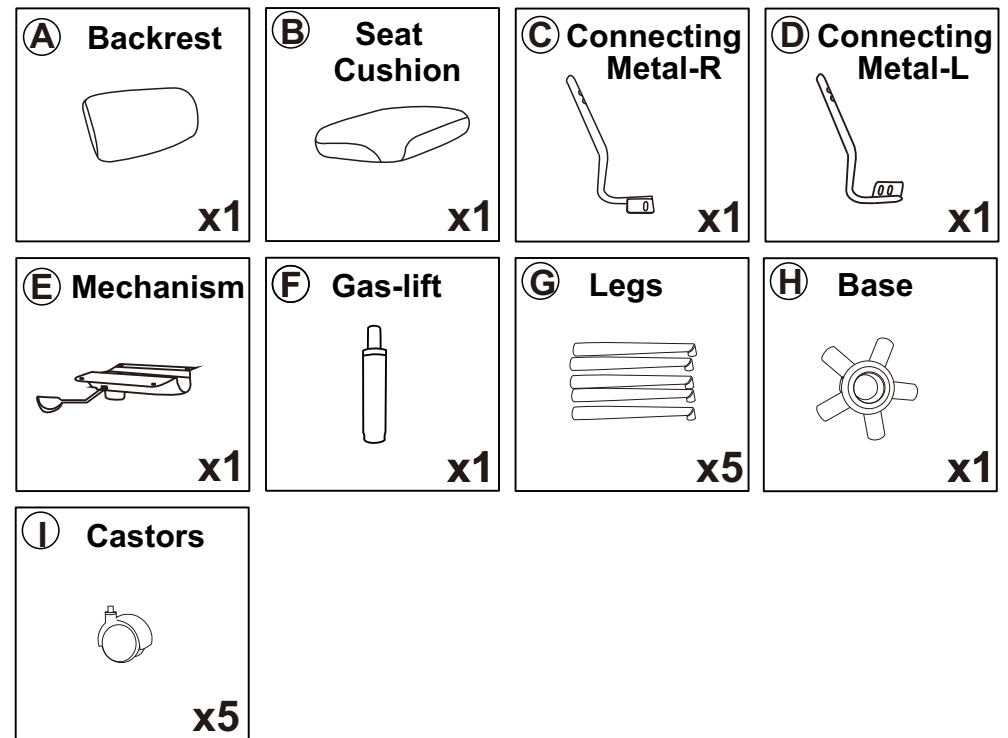

Kind Reminder:

Due to the size of our product, it would be easier to assemble it with your partner together.

STEP 1

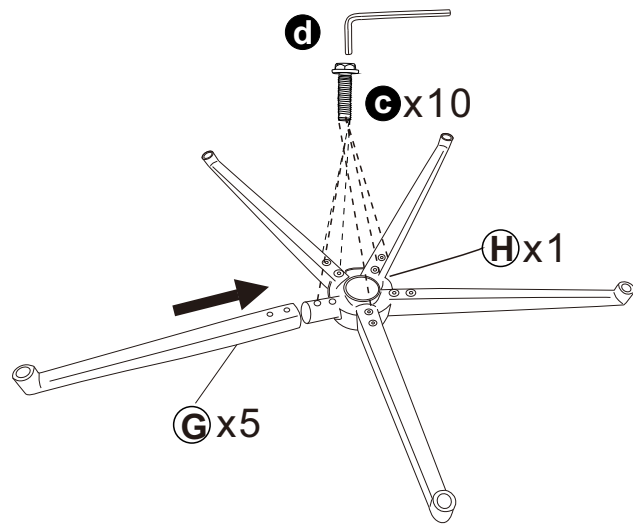

C x10

d x1

STEP 2

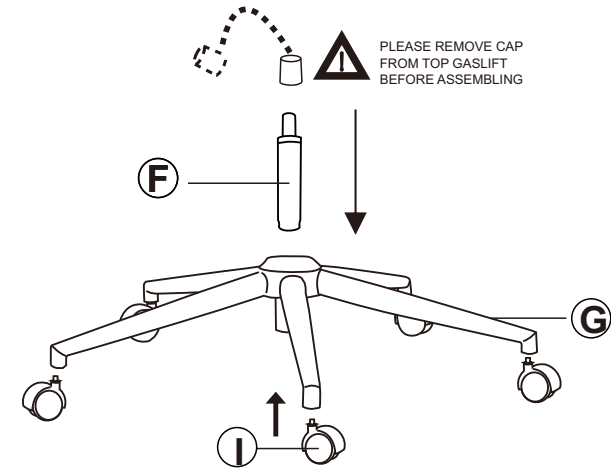

Note:

Please kindly note that the cap should be removed from the top of the gaslift before assembling.

STEP 3

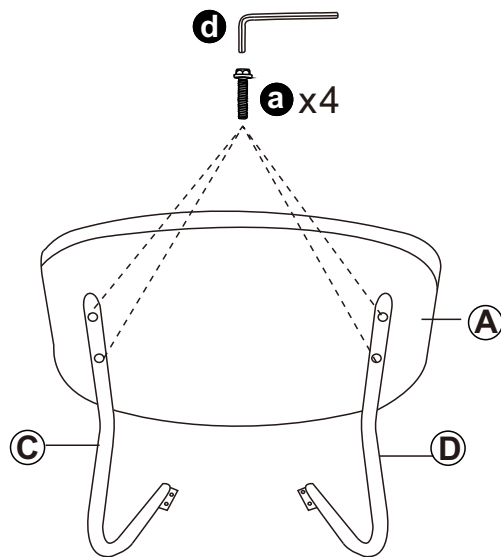

Note:

Screwing all the **a** on the chair (tighten 50% of screws first), and then tighten 100% of all screws. It might help you assemble more easily.

a x4

d x1

STEP 4

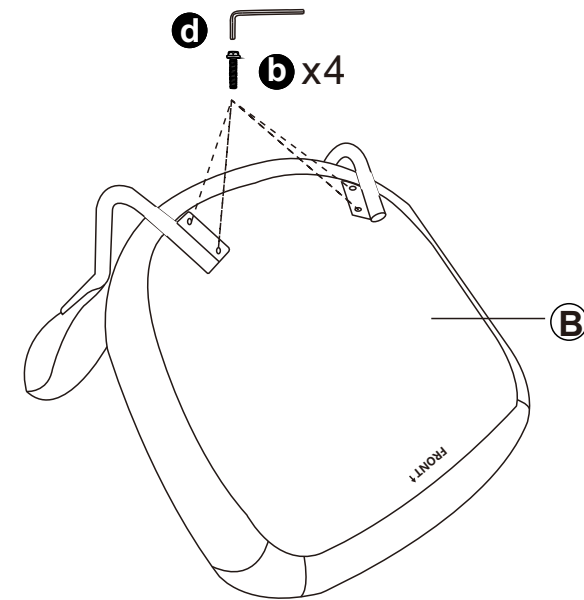

Note:

Screwing all the **b** on the chair (tighten 50% of screws first), and then tighten 100% of all screws. It might help you assemble more easily.

b x4

d x1

STEP 5

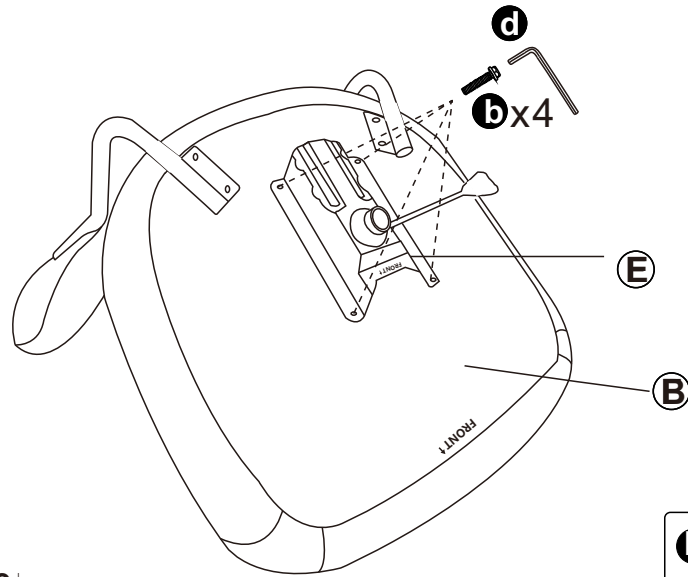

Note:

Make sure the "FRONT" direction of Mechanism (E) and Seat Cushion (B) are the same.

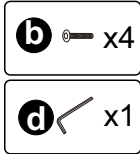

STEP 6

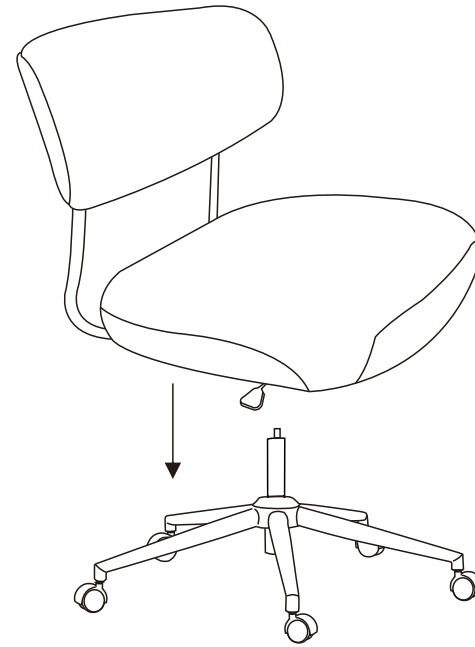

STEP 7

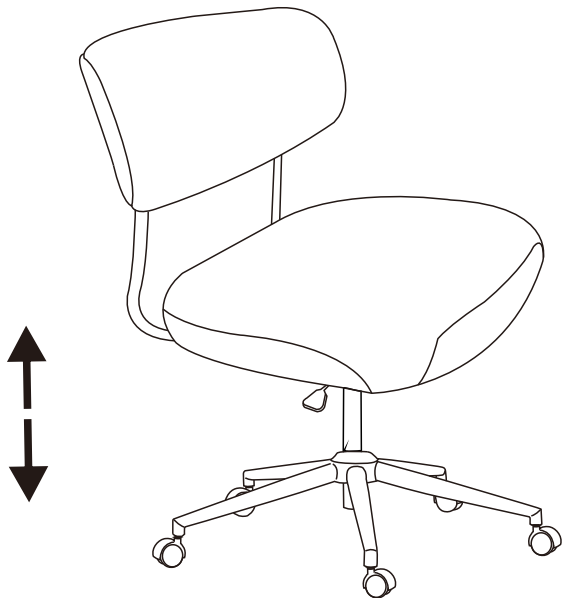

Note:

Before using the chair, please kindly check all screws are fully tightened.