

## Panel bed-K Assembly Instructions

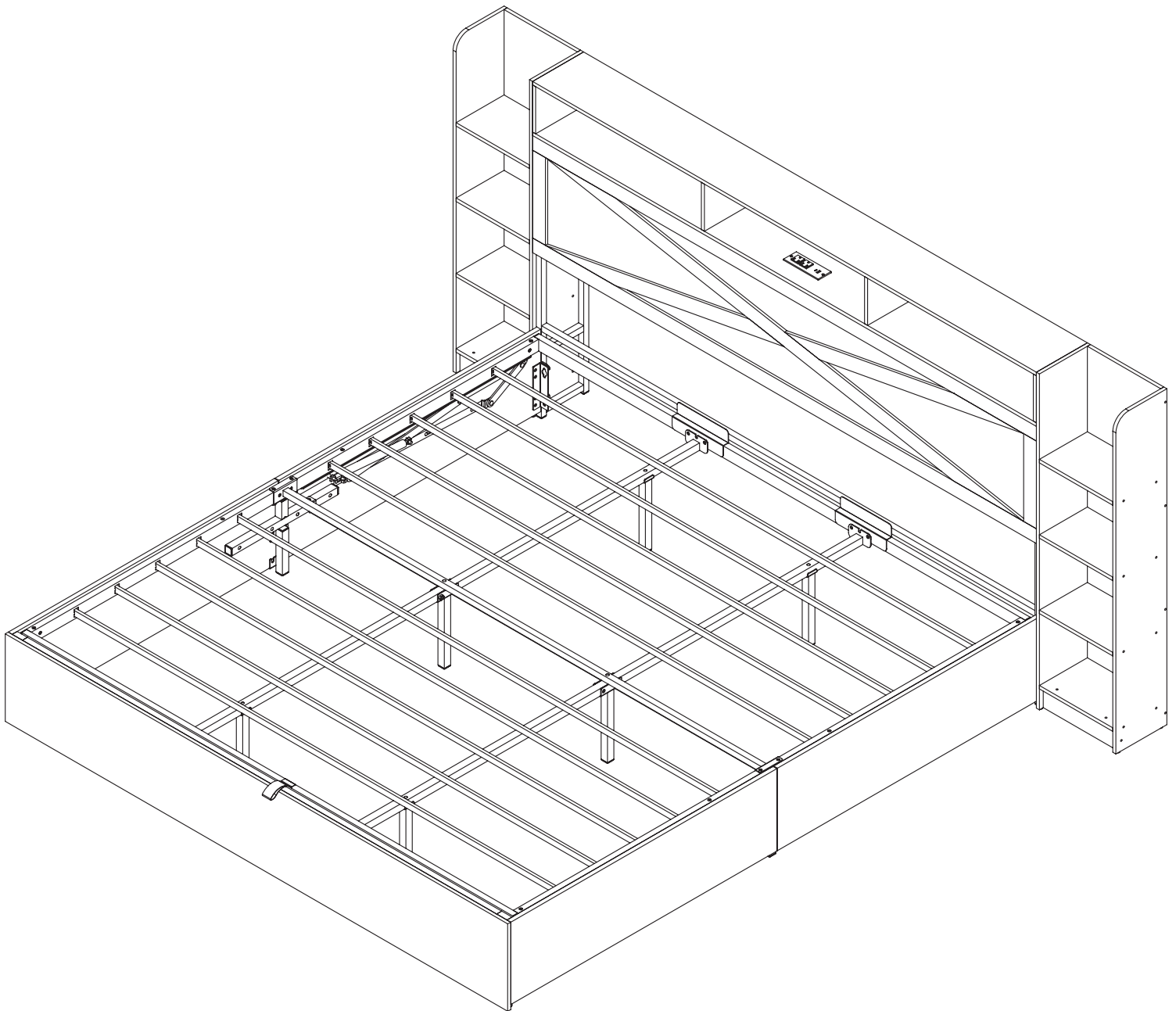

### **Dear Customers,**

Thank you for purchasing our product. Please read this instruction manual carefully after receiving this product. It will help you assemble this product quickly, safely and correctly. You can keep this manual for future reference.

MADE IN CHINA

## ! IMPORTANT

Please follow the instruction manuals and use a pad to protect the product during your assembly.

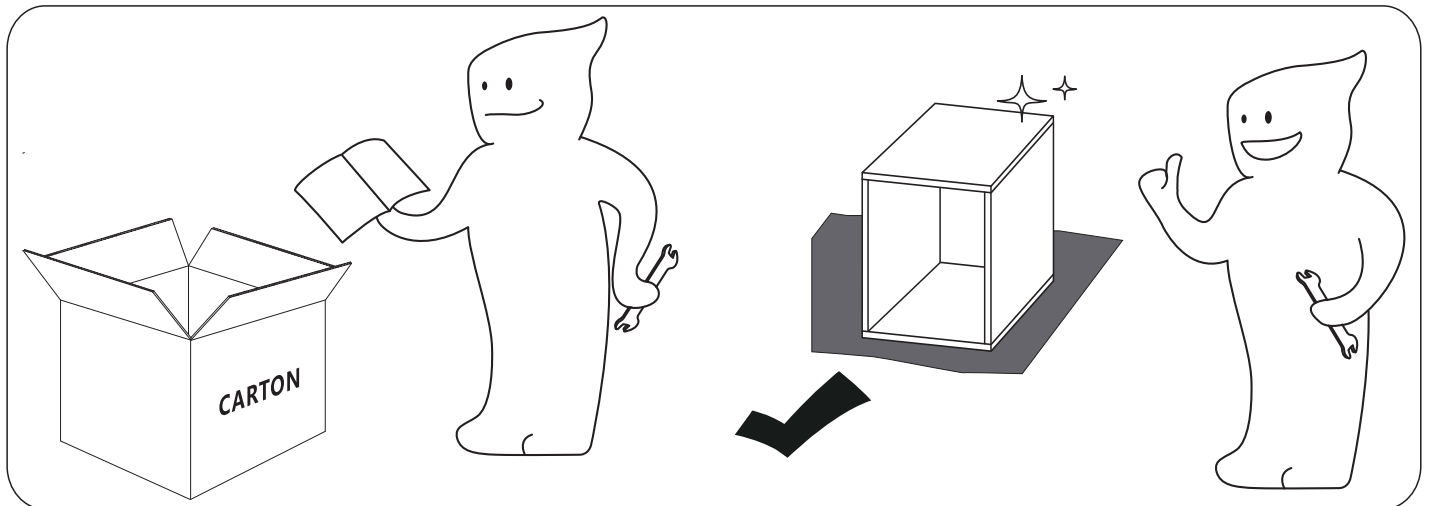
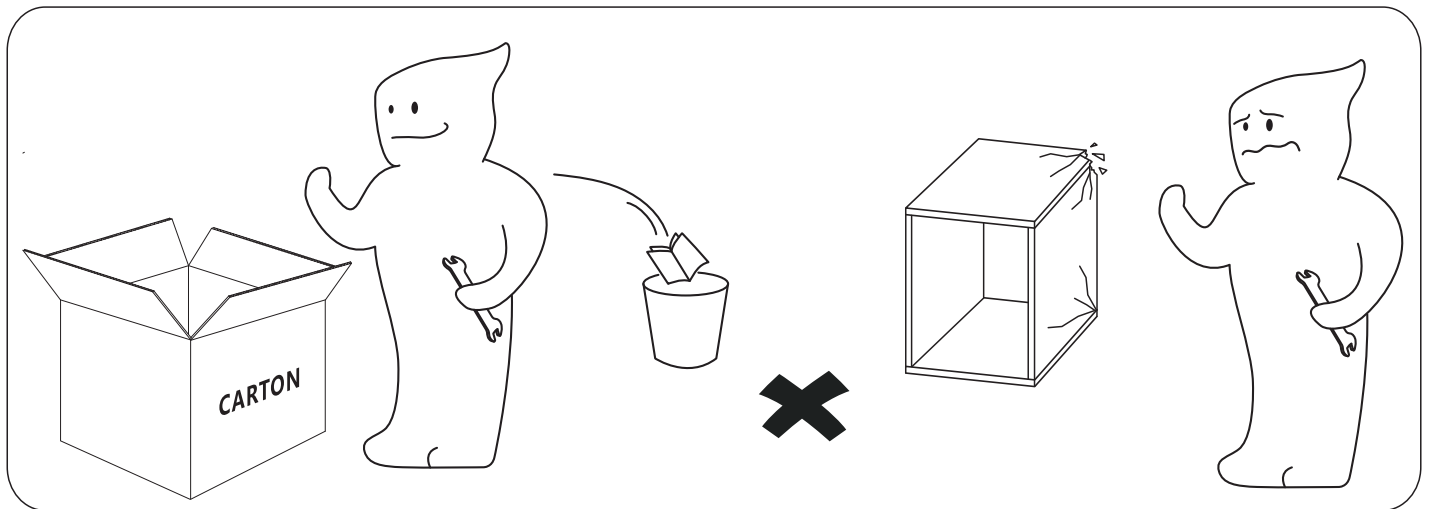

**Note:**

1. Should be assembled on flat ground to keep balance.
2. Before completing the installation, do not tighten the screws.



For easier and better assembly, **2** or more adults are required.

# ASSEMBLY INSTRUCTIONS

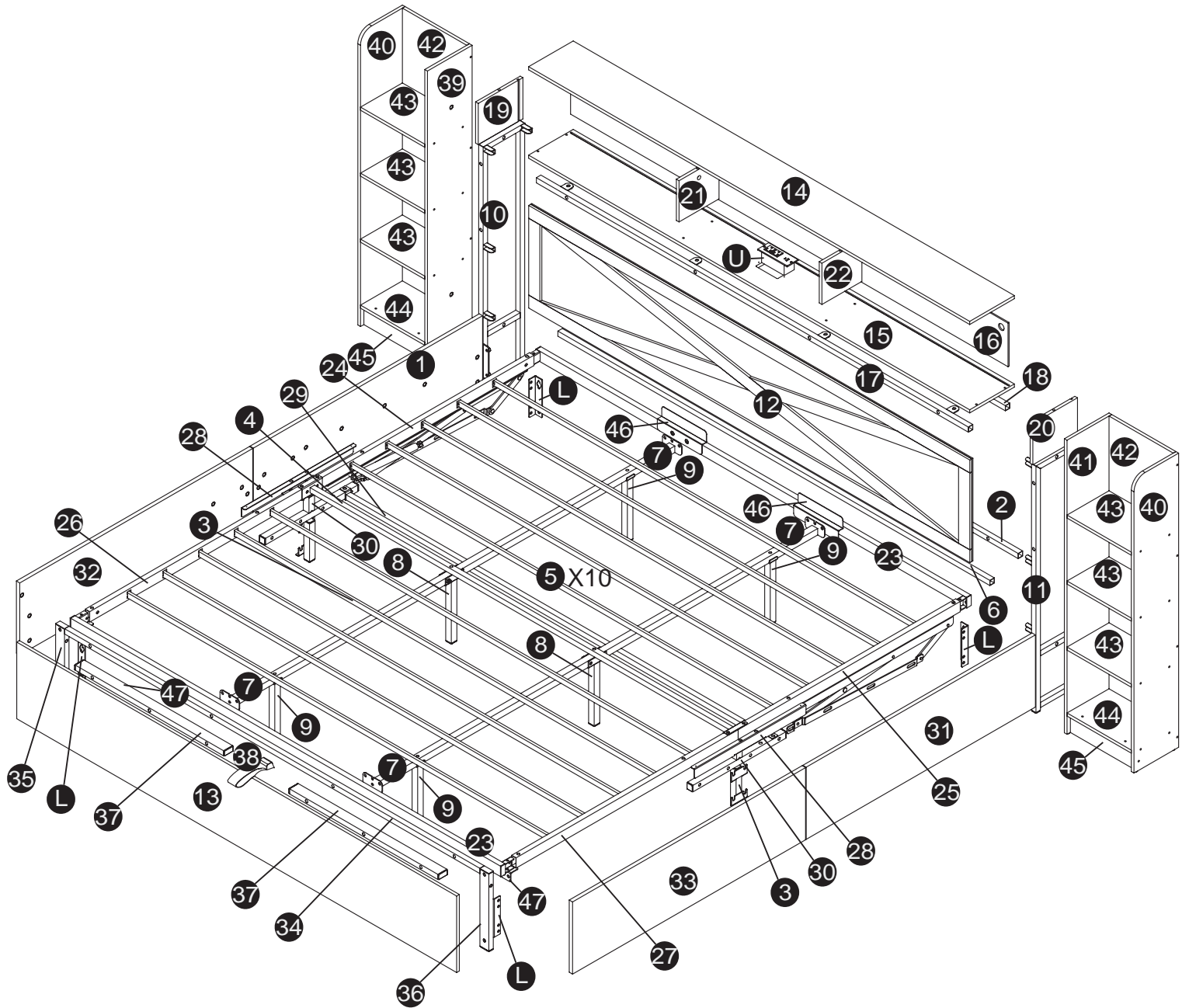

# ASSEMBLY INSTRUCTIONS

## The box 1

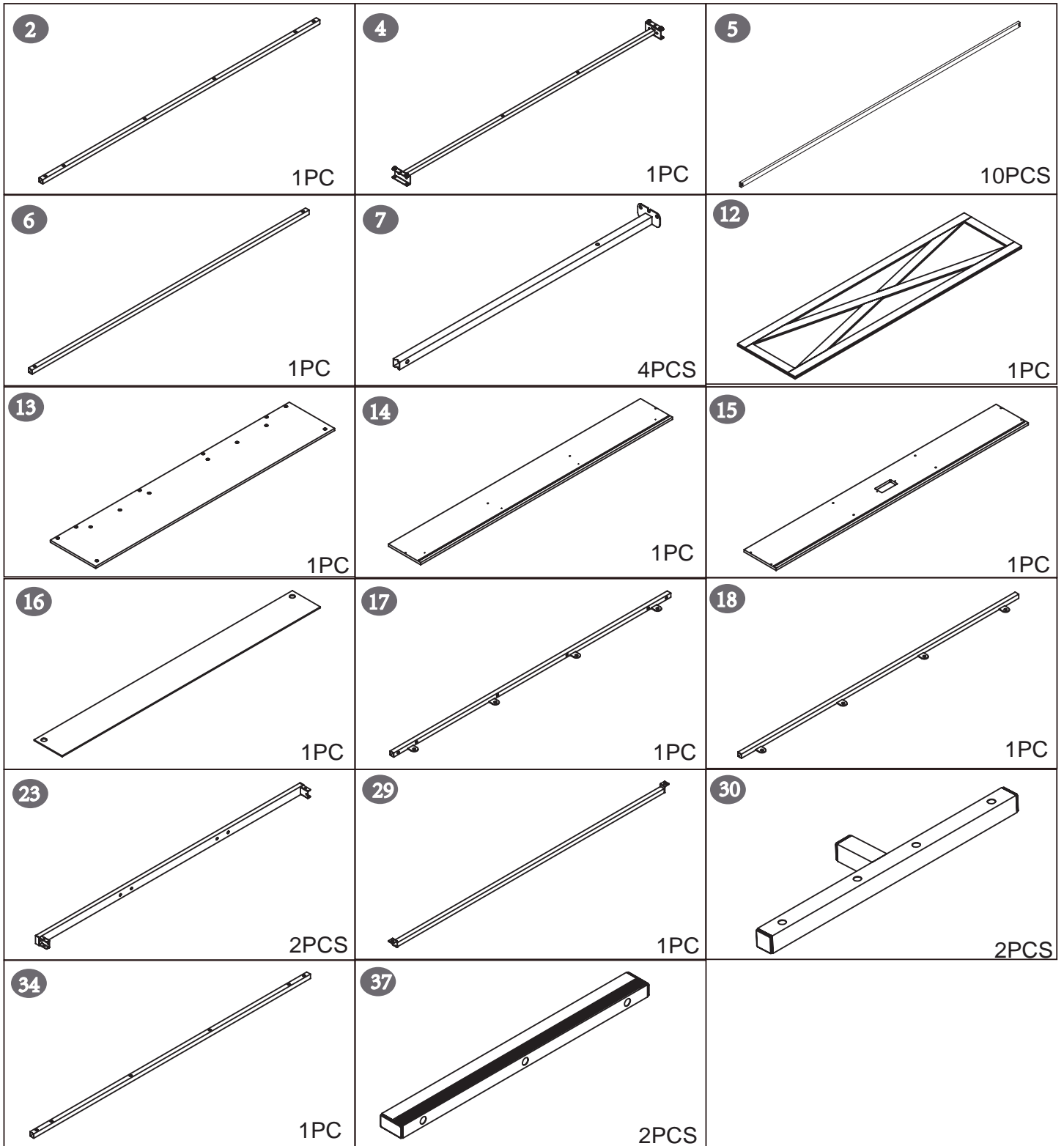

# ASSEMBLY INSTRUCTIONS

## The box 2

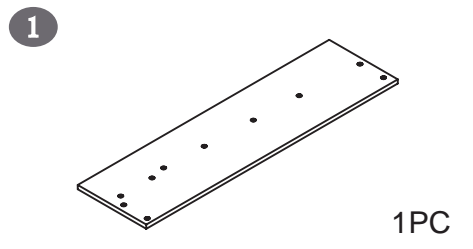
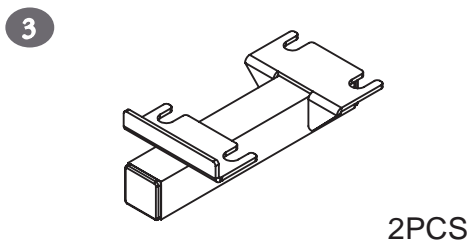
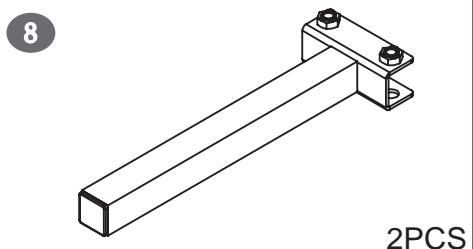
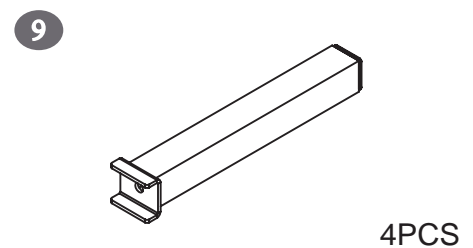
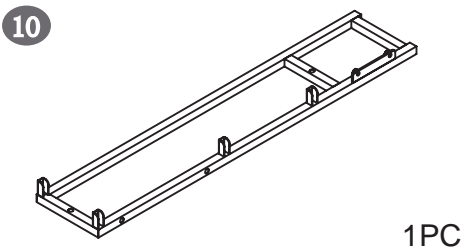
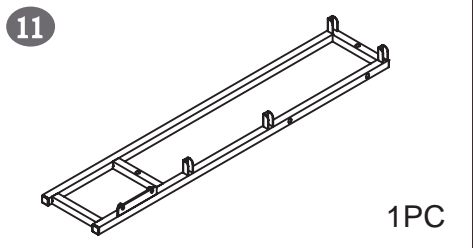
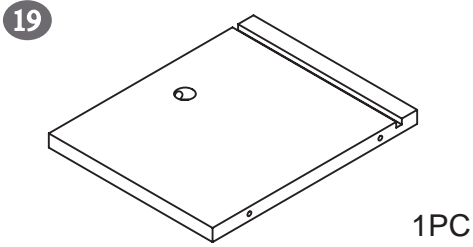
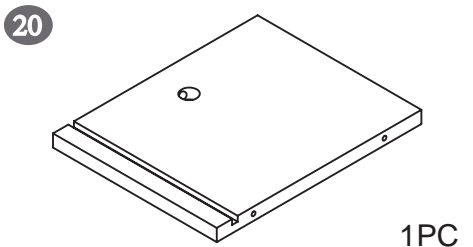
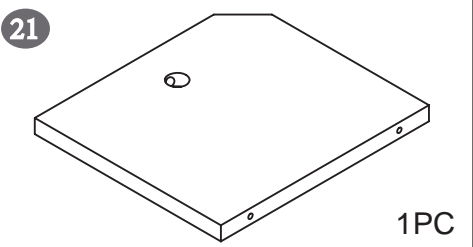
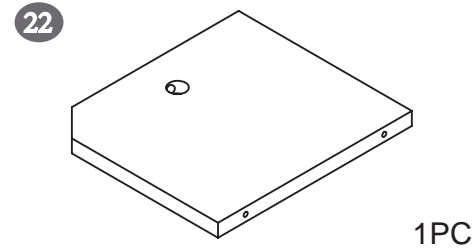
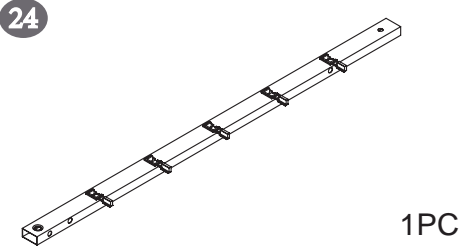
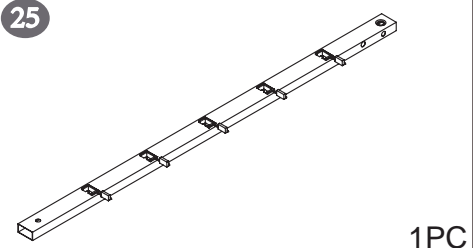
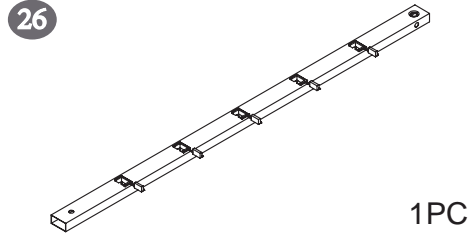
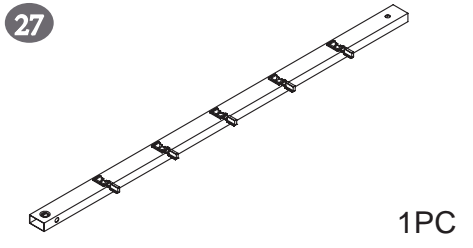
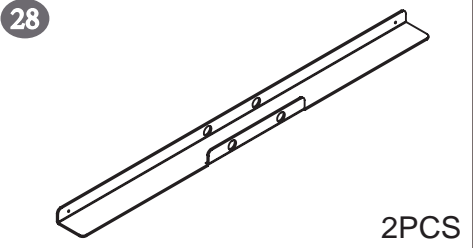
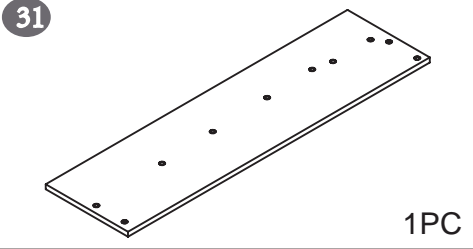
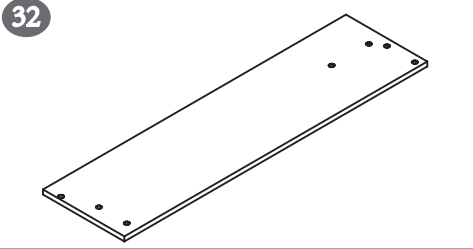
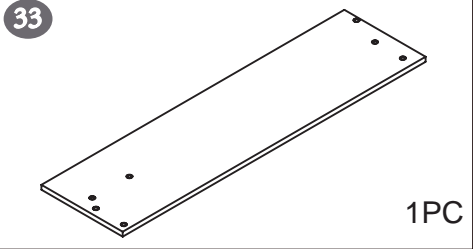
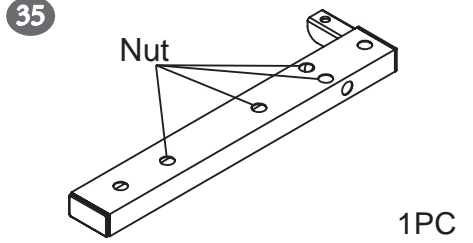
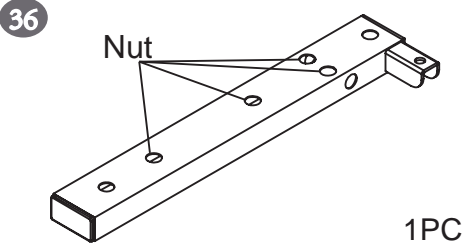
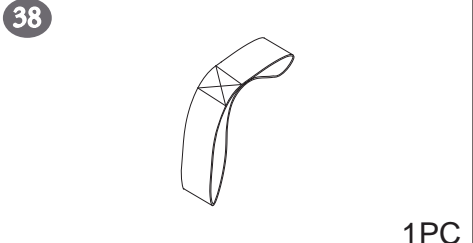
 <p>1 1PC</p>	 <p>3 2PCS</p>	 <p>8 2PCS</p>
 <p>9 4PCS</p>	 <p>10 1PC</p>	 <p>11 1PC</p>
 <p>19 1PC</p>	 <p>20 1PC</p>	 <p>21 1PC</p>
 <p>22 1PC</p>	 <p>24 1PC</p>	 <p>25 1PC</p>
 <p>26 1PC</p>	 <p>27 1PC</p>	 <p>28 2PCS</p>
 <p>31 1PC</p>	 <p>32 1PC</p>	 <p>33 1PC</p>
 <p>35 1PC</p>	 <p>36 1PC</p>	 <p>38 1PC</p>





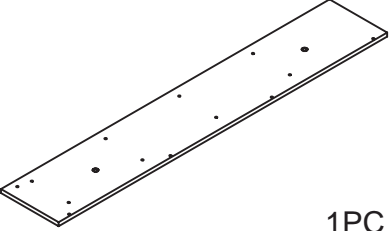
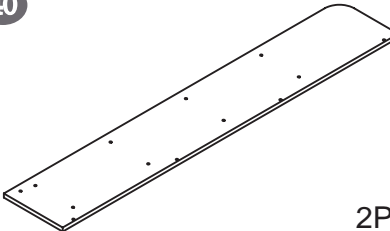
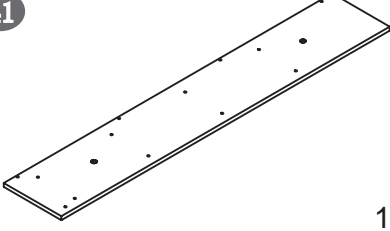
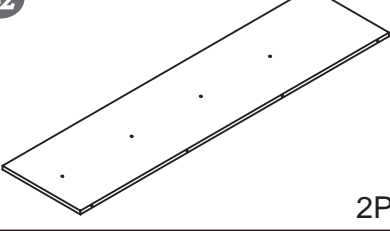
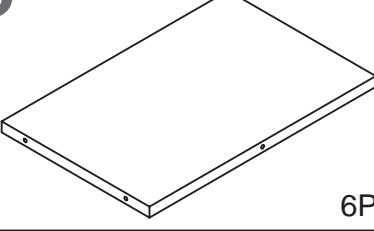
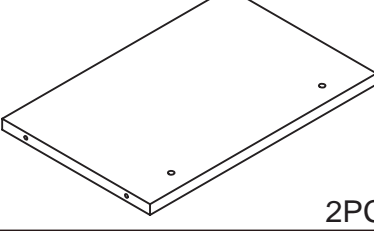
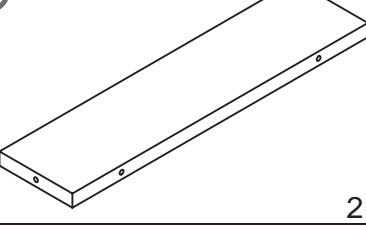
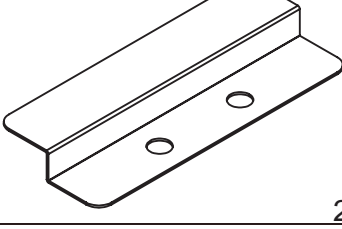
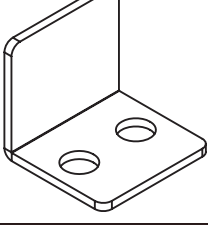
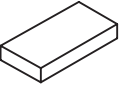
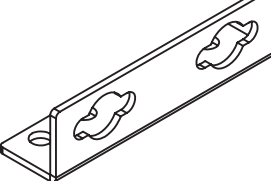
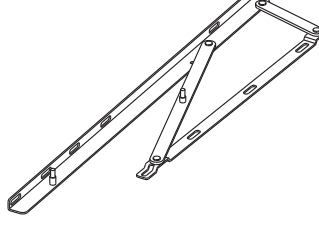
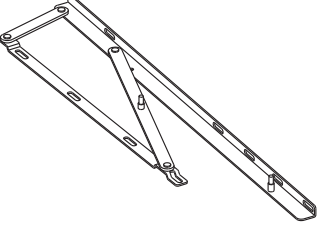
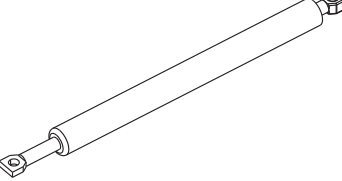
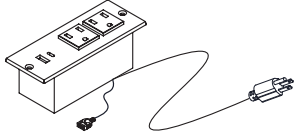
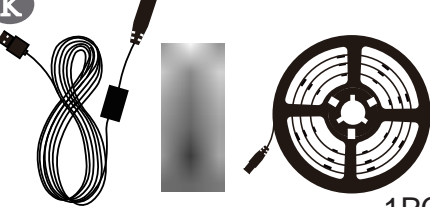



# ASSEMBLY INSTRUCTIONS

## The box 2 continued

<b>39</b>  1PC	<b>40</b>  2PCS	<b>41</b>  1PC
<b>42</b>  2PCS	<b>43</b>  6PCS	<b>44</b>  2PCS
<b>45</b>  2PCS	<b>46</b>  2PCS	<b>47</b>  2PCS
<b>48</b>  3PCS	<b>L</b>  4PCS	<b>Q1</b>  1PC
<b>Q2</b>  1PC	<b>Q3</b>  2PCS	<b>U</b>  1PC
<b>K</b>  1PC		

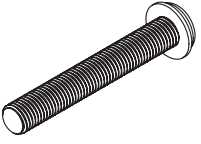
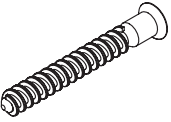
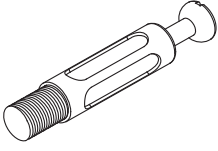
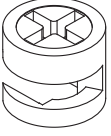
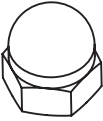
# ASSEMBLY INSTRUCTIONS

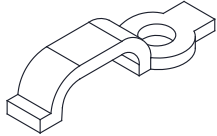
## The list of vacuum-formed packages in Box 2

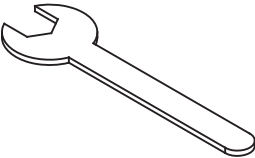
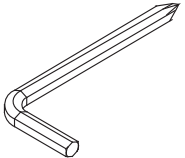
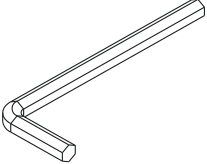
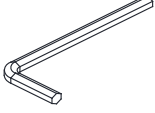
<b>A</b>  M8x12 68PCS	<b>B</b>  M8x18 Colored Zinc 16PCS	<b>C</b>  M8x28 24PCS
<b>D</b>  M8x35 16PCS	<b>E</b>  M8x50 Colored Zinc 8PCS	<b>F</b>  M8x55 6PCS
<b>G</b>  M5x40 72PCS	<b>H</b>  φ7x40 4PCS	<b>I</b>  φ15x9.5 4PCS
<b>J</b>  4PCS	<b>M</b>  ST4.2x12 2PCS	<b>N</b>  4PCS
<b>O</b>  ST3.2x12 4PCS	<b>P</b>  1PC	<b>Q</b>  M8 1PC
<b>R</b>  M8 1PC	<b>S</b>  M5 1PC	

Do not tighten the screws unless the installation is done. Make sure all bolts are tightly screwed before you use it.



# ASSEMBLY INSTRUCTIONS

1

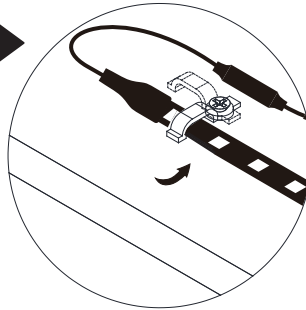
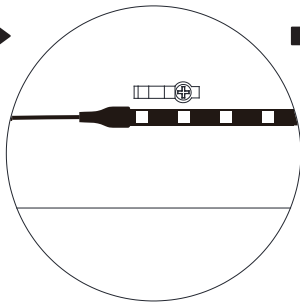
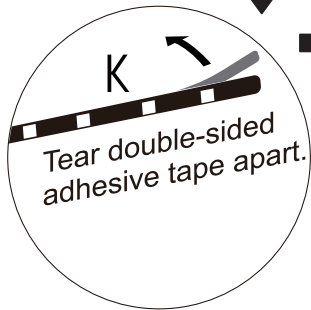
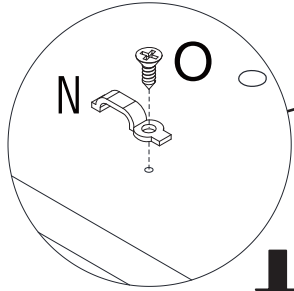
Accessory N is not locked tight at first



Fastening accessories N

K		1pc
O	 ST3. 2x12	4pcs
N		4pcs

2

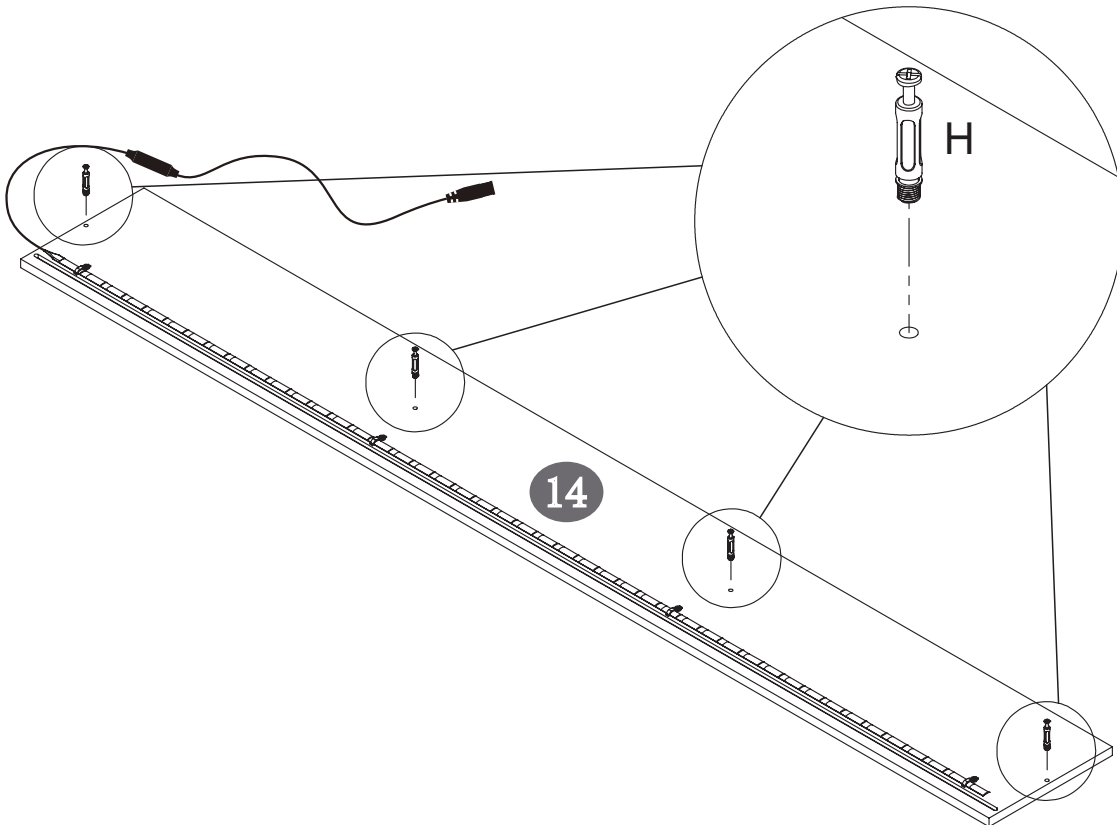

H	 φ7x40	4pcs
---	--	------



# ASSEMBLY INSTRUCTIONS

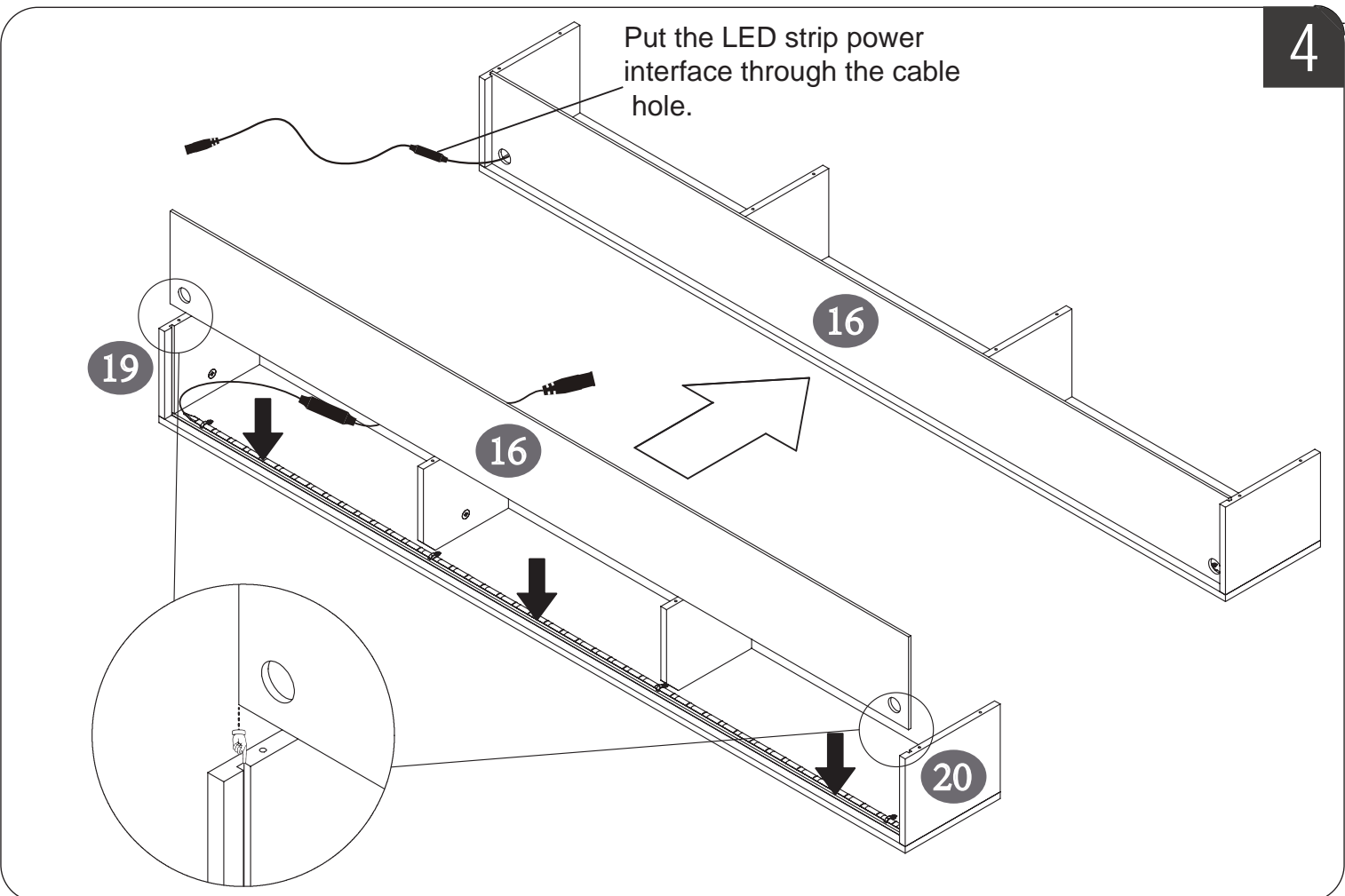
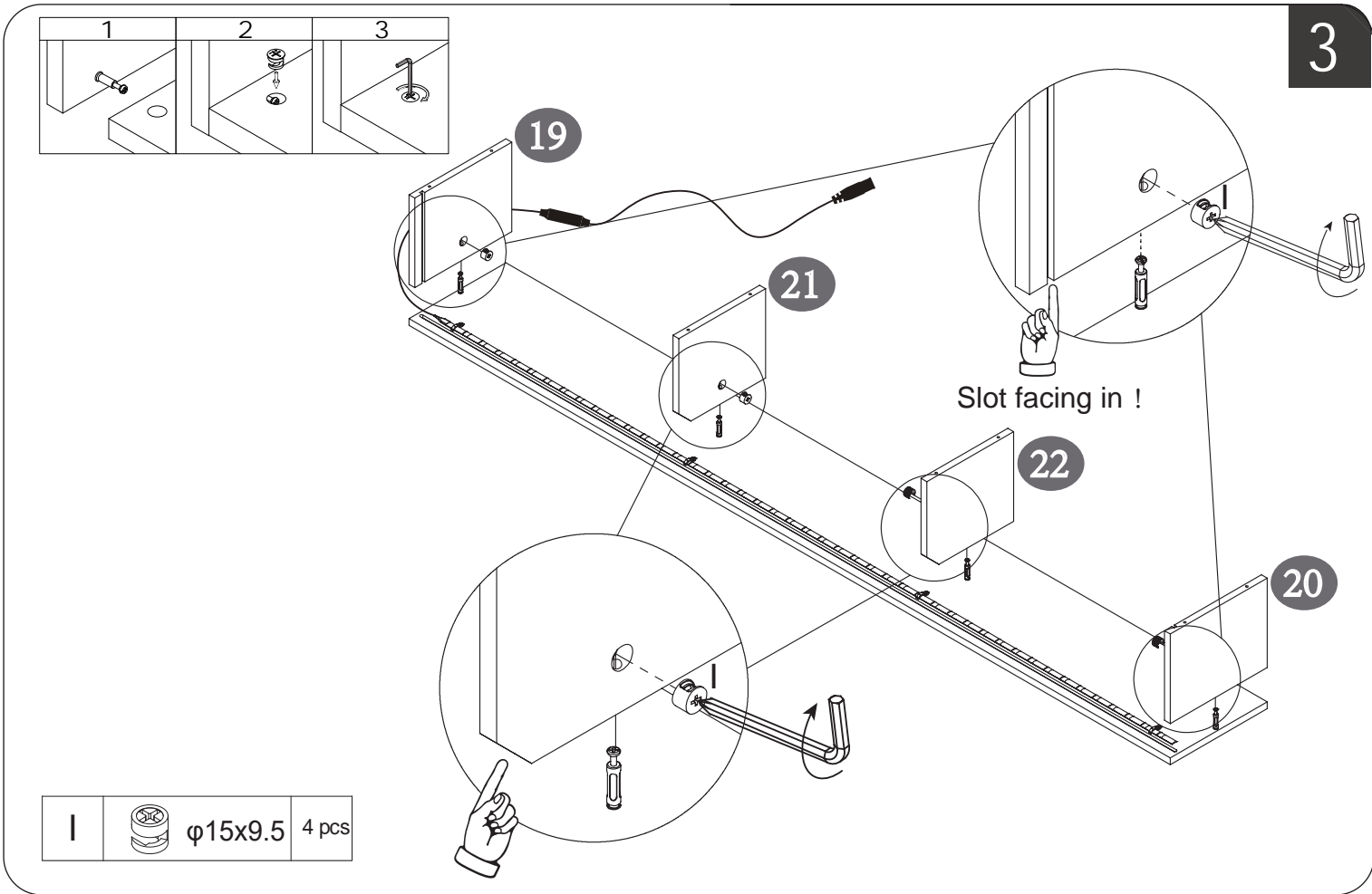

5

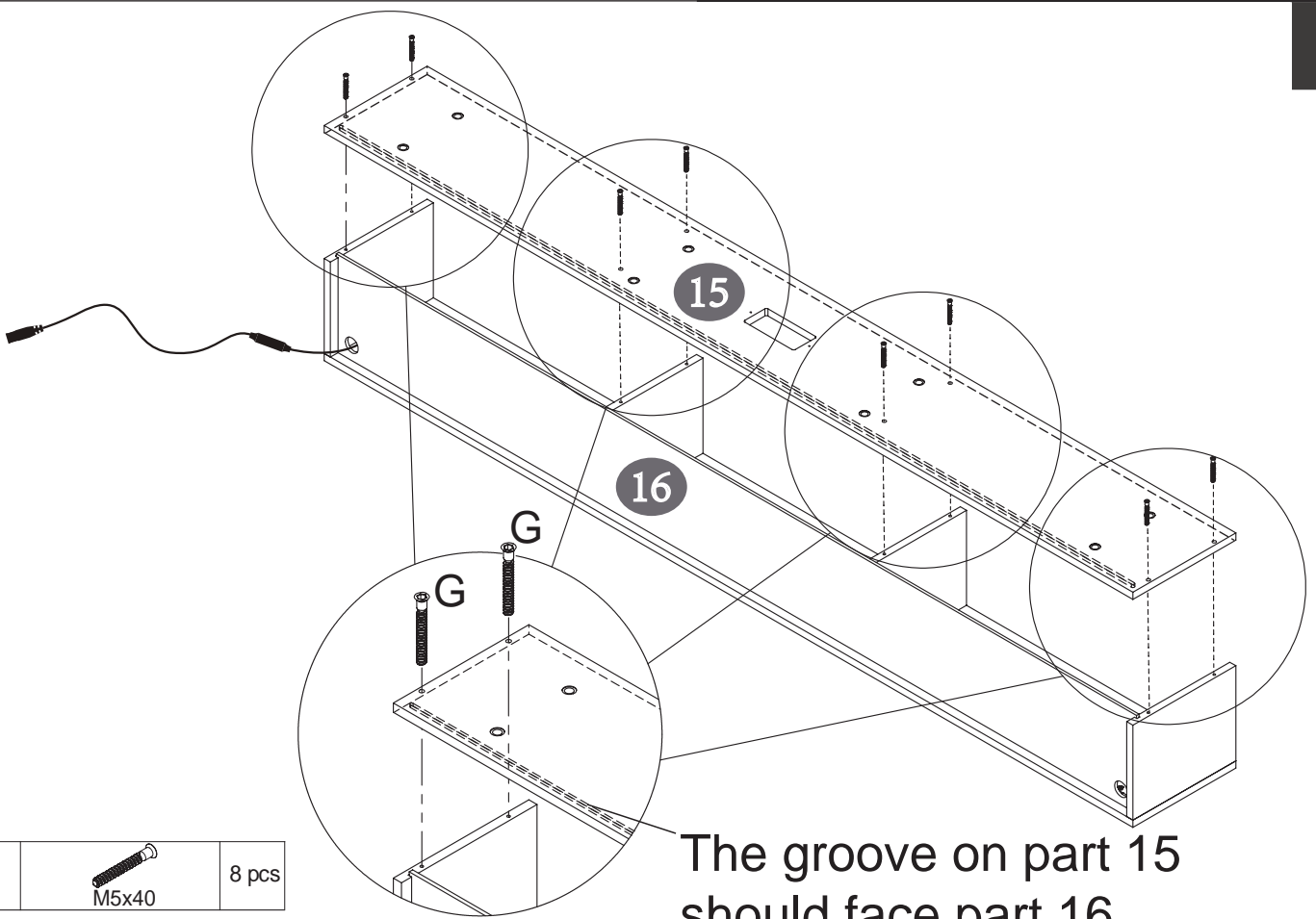



The groove on part 15 should face part 16.

G	 M5x40	8 pcs
---	--	-------

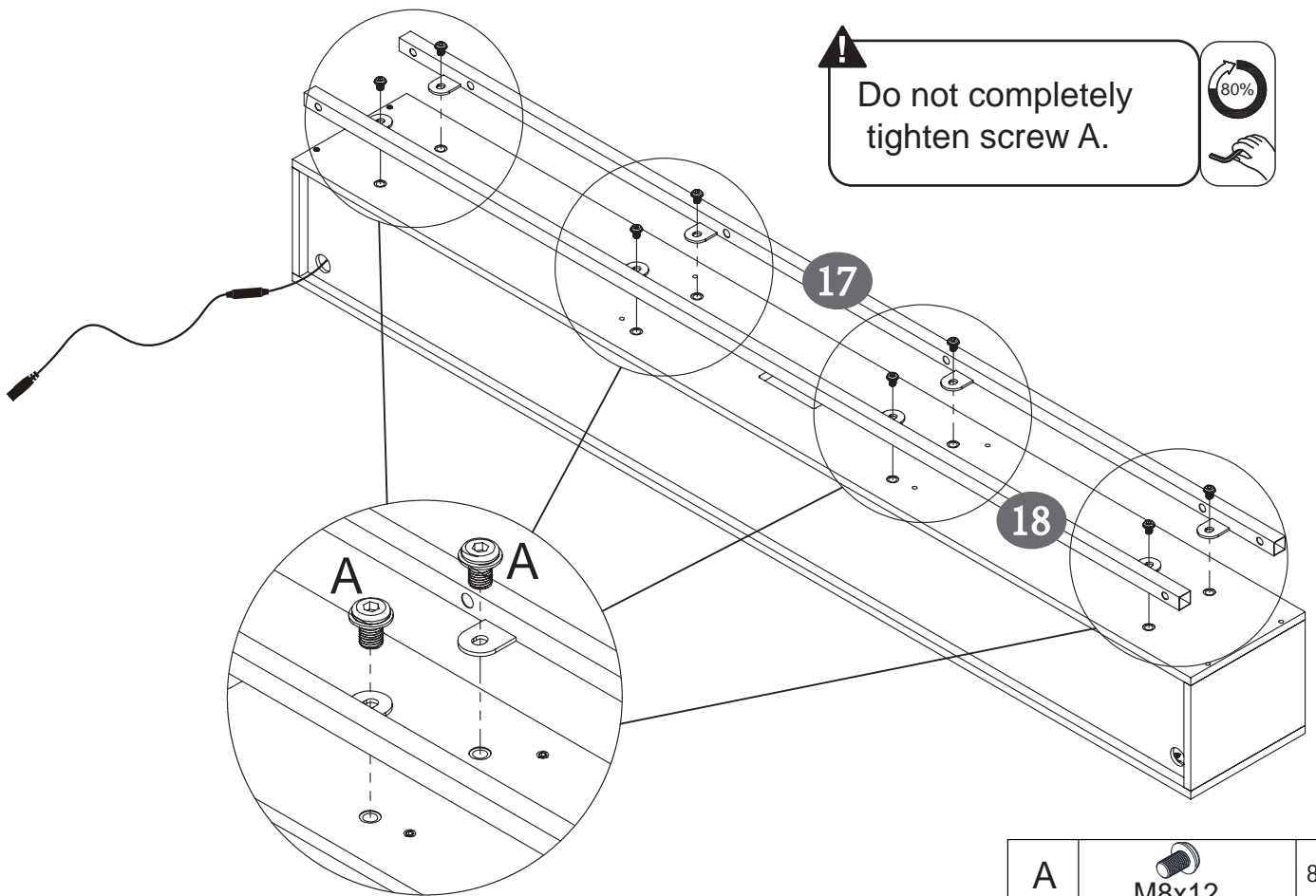
6



 Do not completely tighten screw A. 

A	 M8x12	8pcs
---	--	------

# ASSEMBLY INSTRUCTIONS

7

⚠ Do not completely tighten screw A.

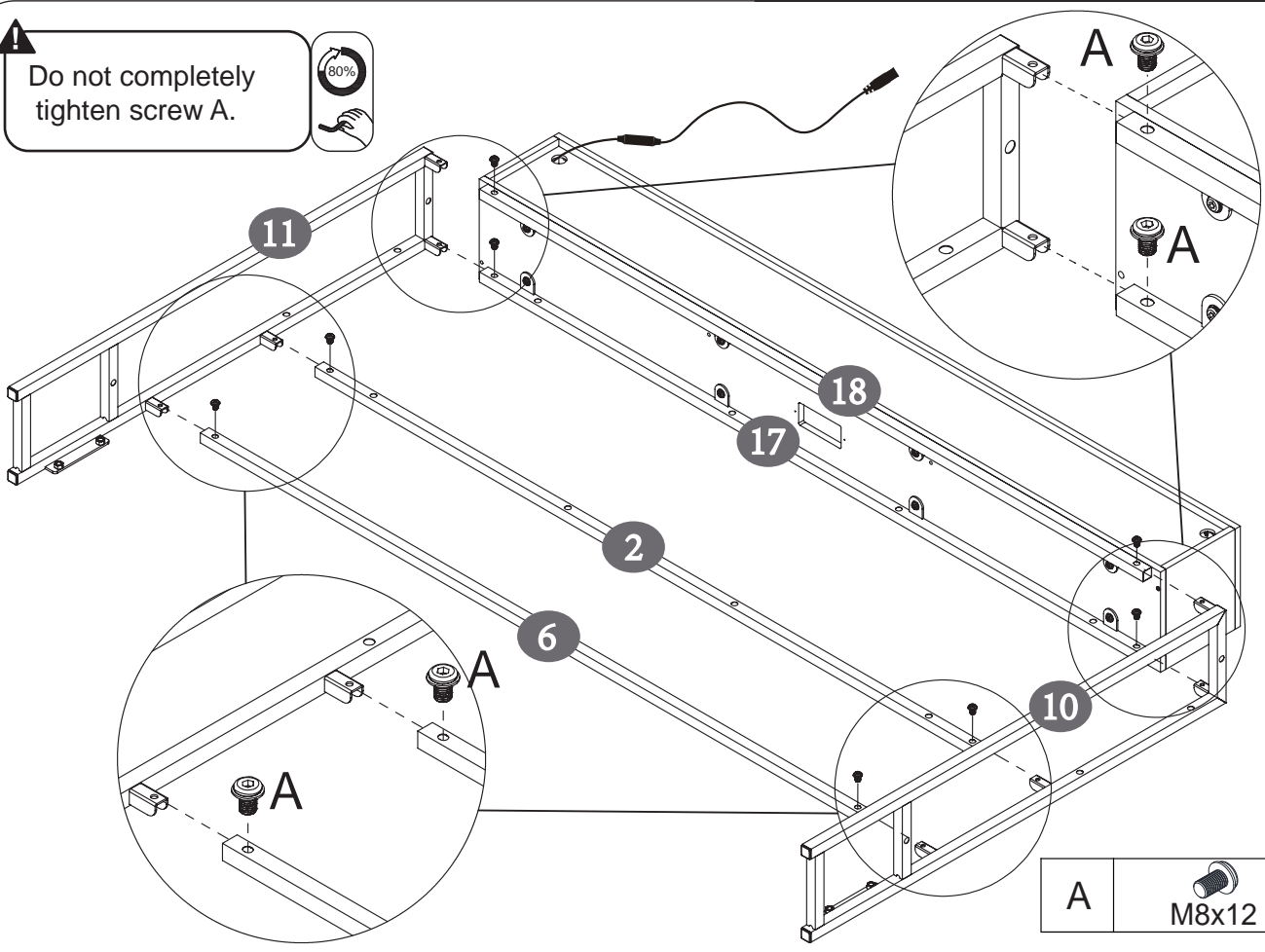

A	 M8x12	8pcs
---	---	------

8

Tighten all the screws.

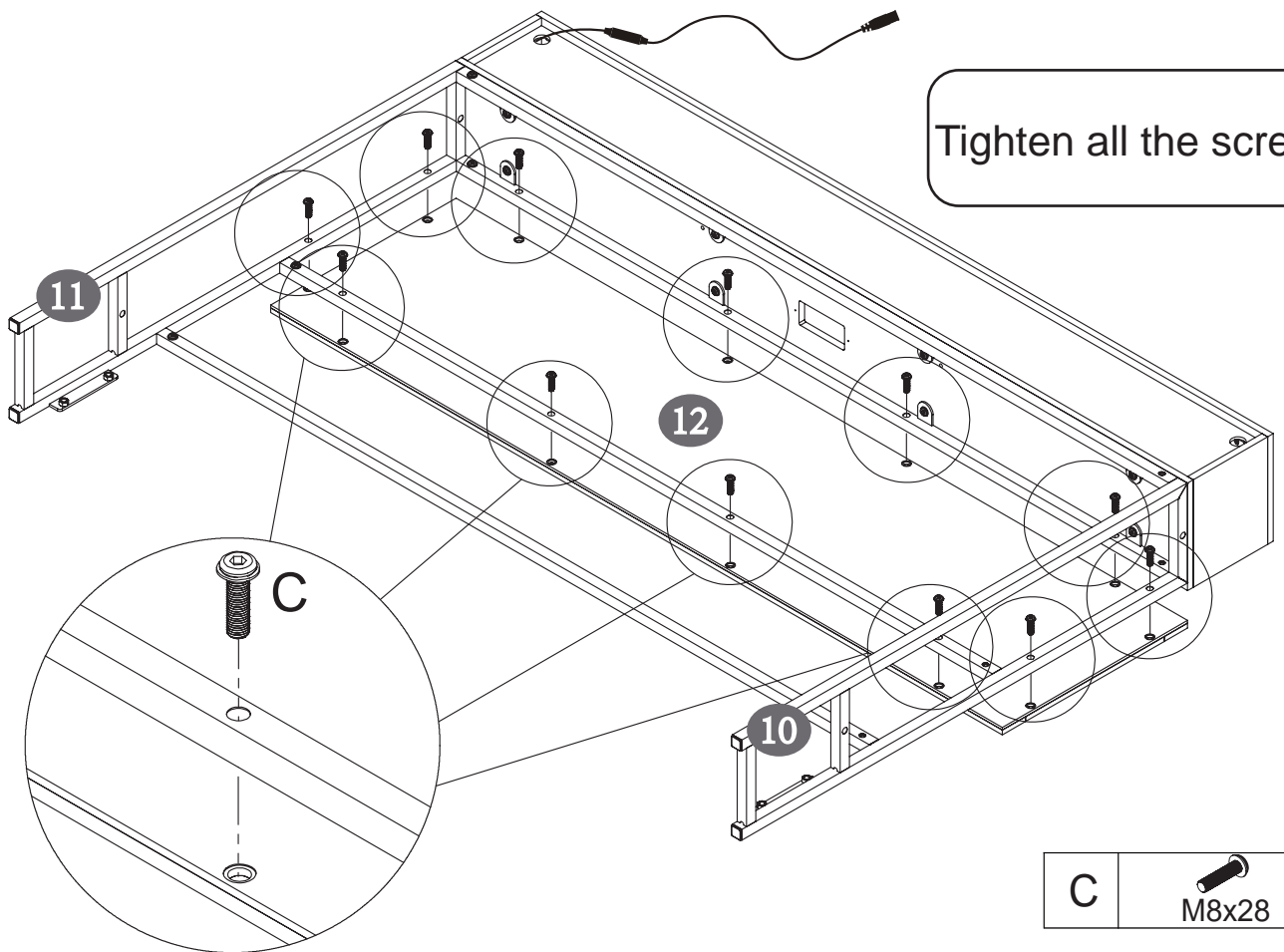

C	 M8x28	12pcs
---	---	-------

# ASSEMBLY INSTRUCTIONS

9

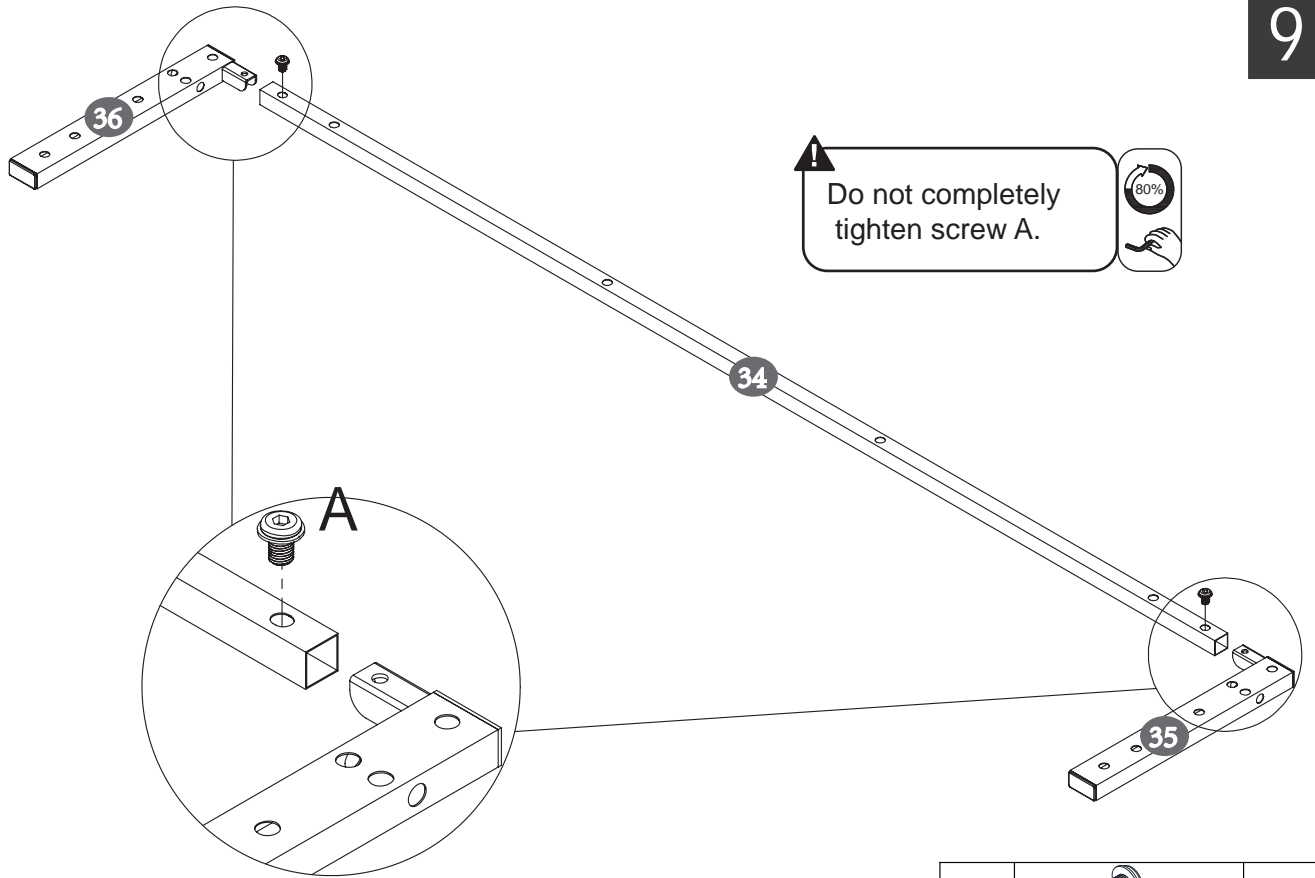

A		2pcs
---	---	------

10

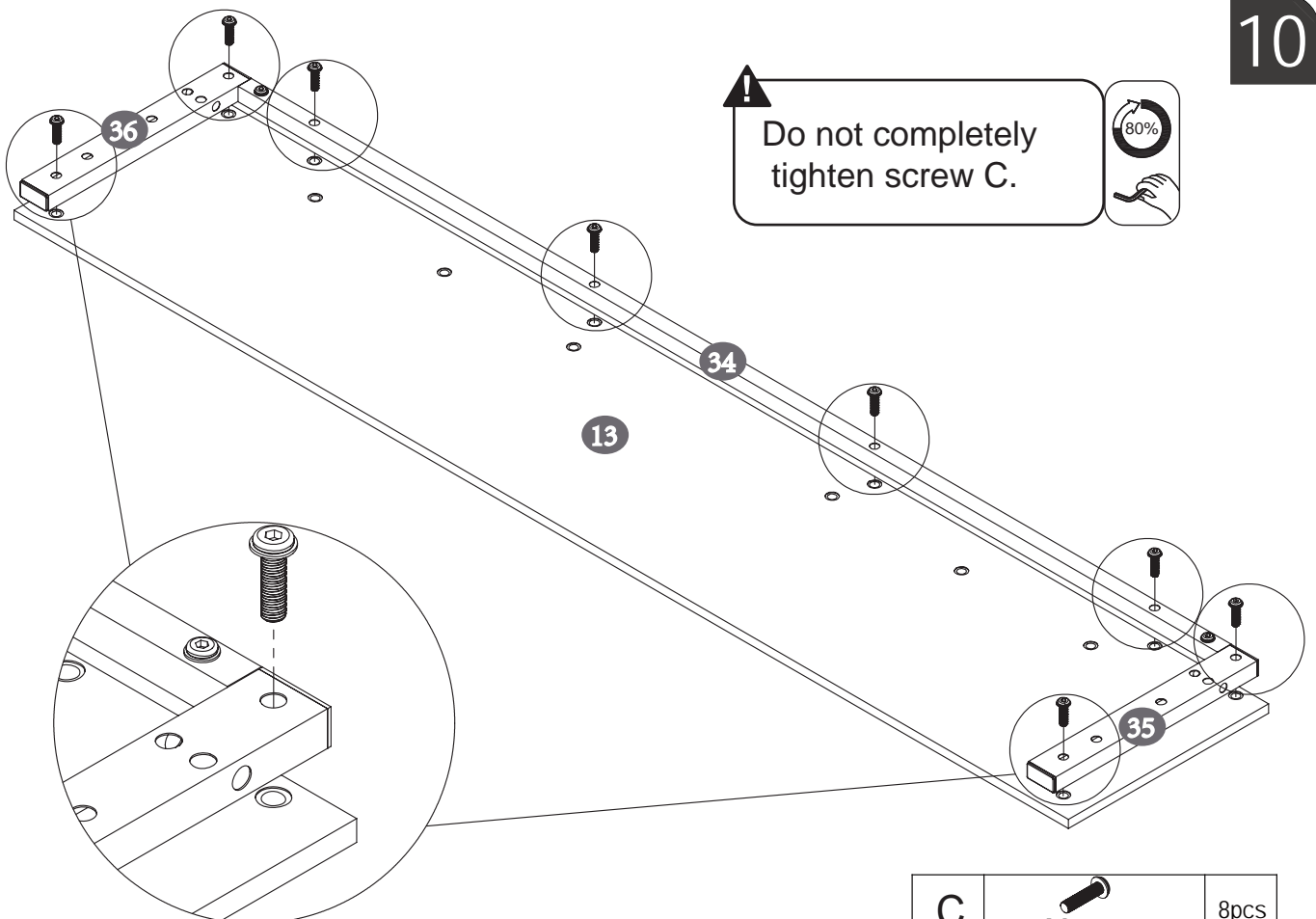

C		8pcs
---	---	------

# ASSEMBLY INSTRUCTIONS

11

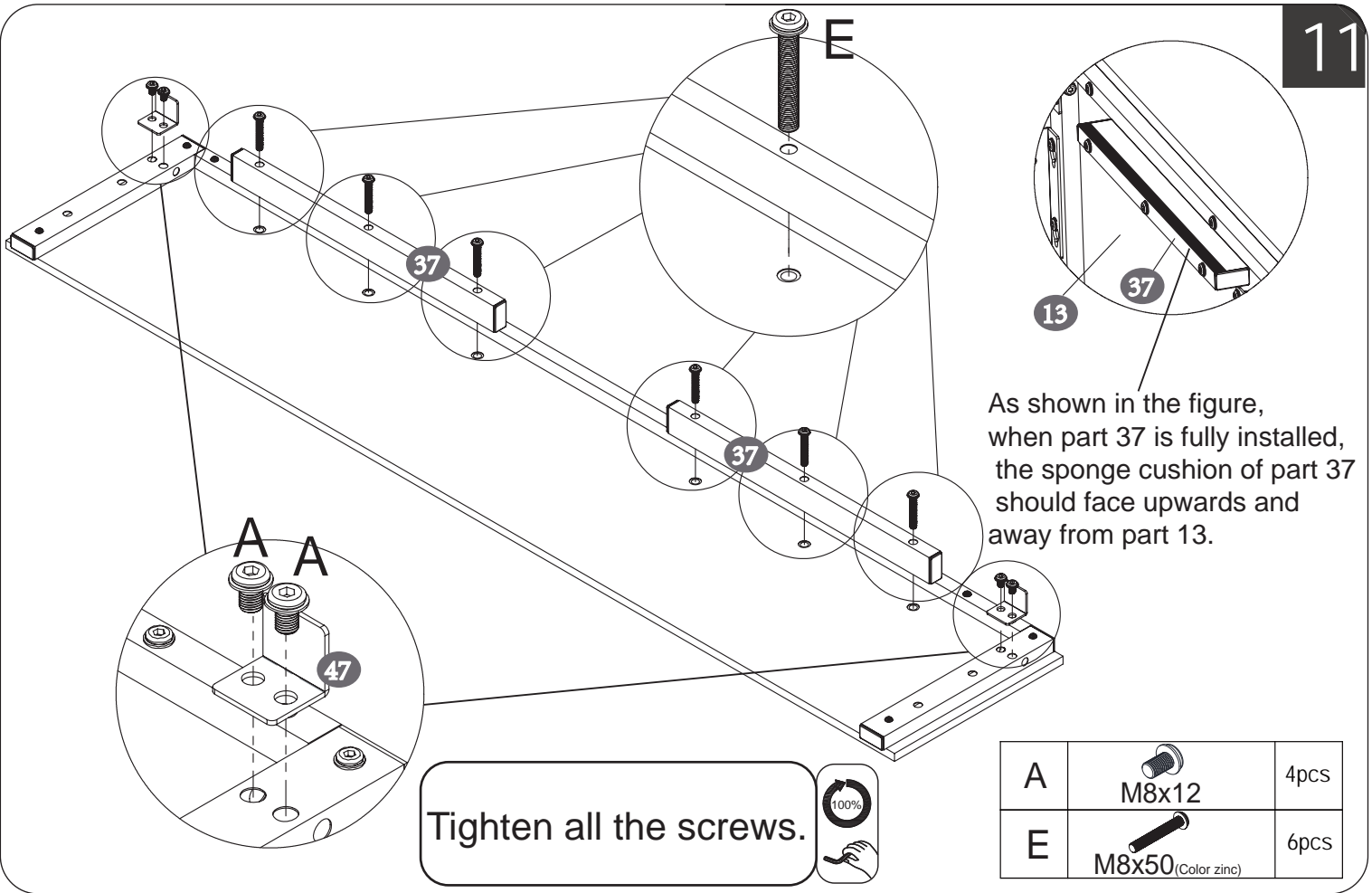

Tighten all the screws. 

A	 M8x12	4pcs
E	 M8x50 (Color zinc)	6pcs

12

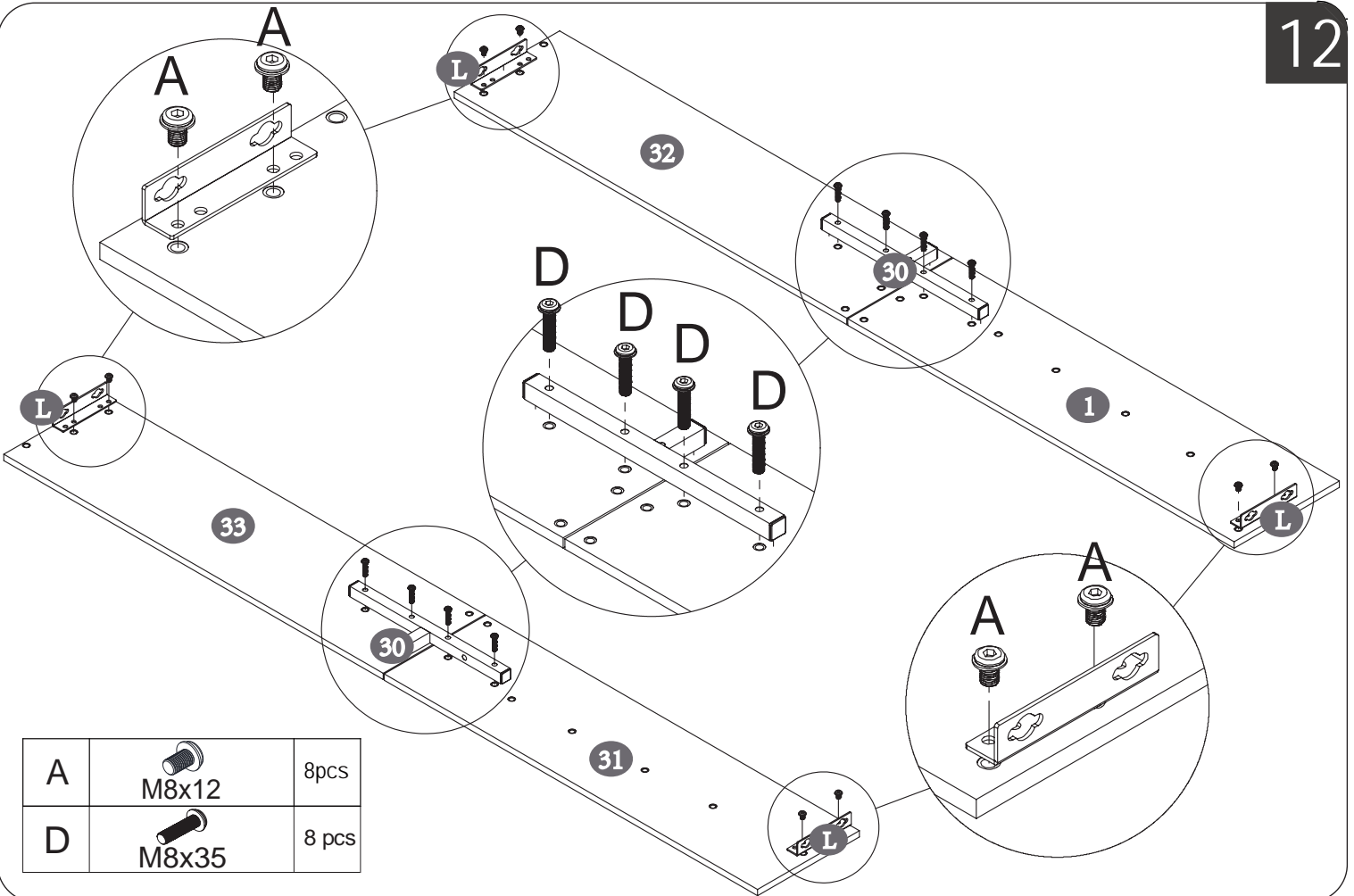

A	 M8x12	8pcs
D	 M8x35	8 pcs

13

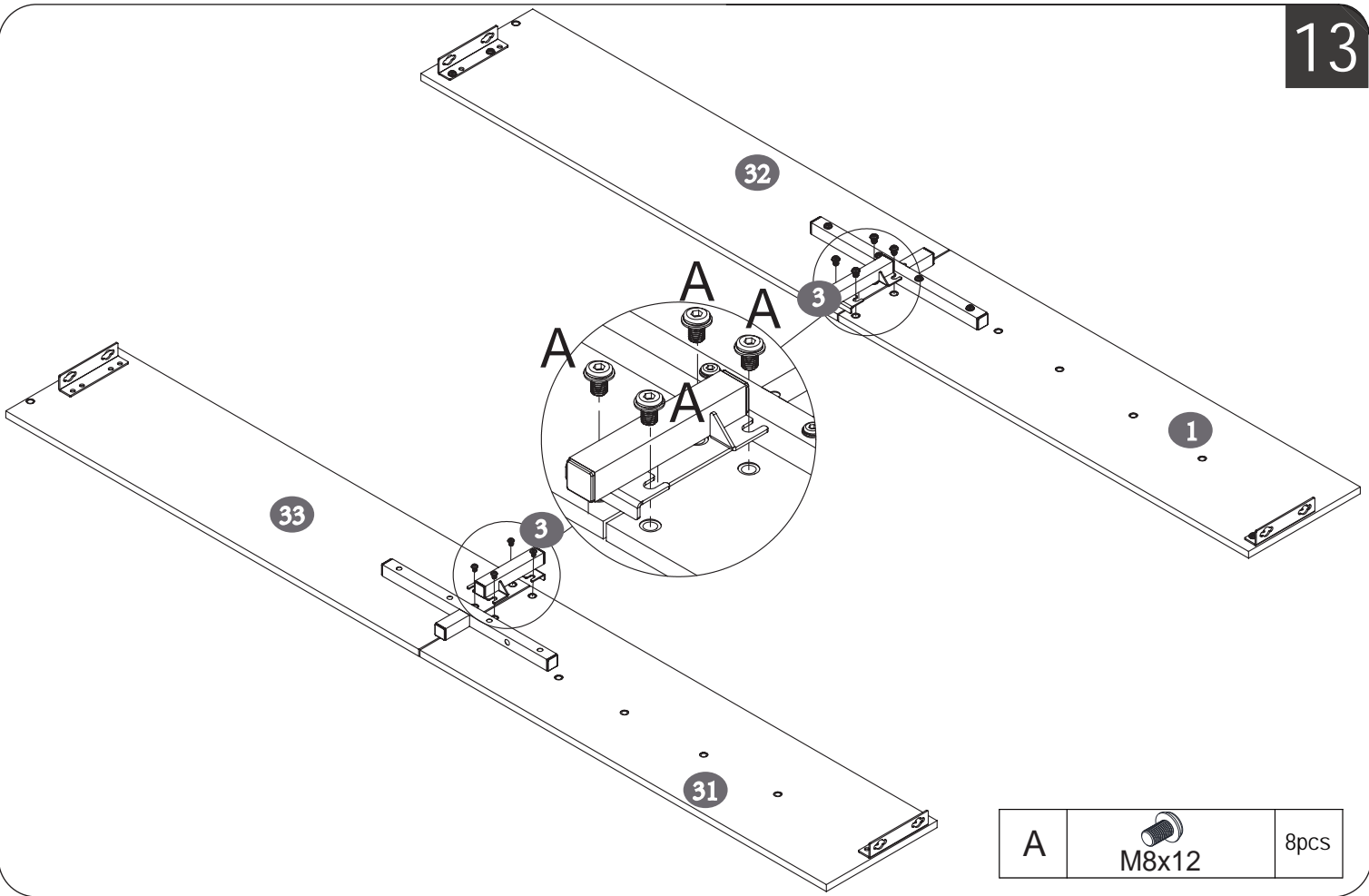

14

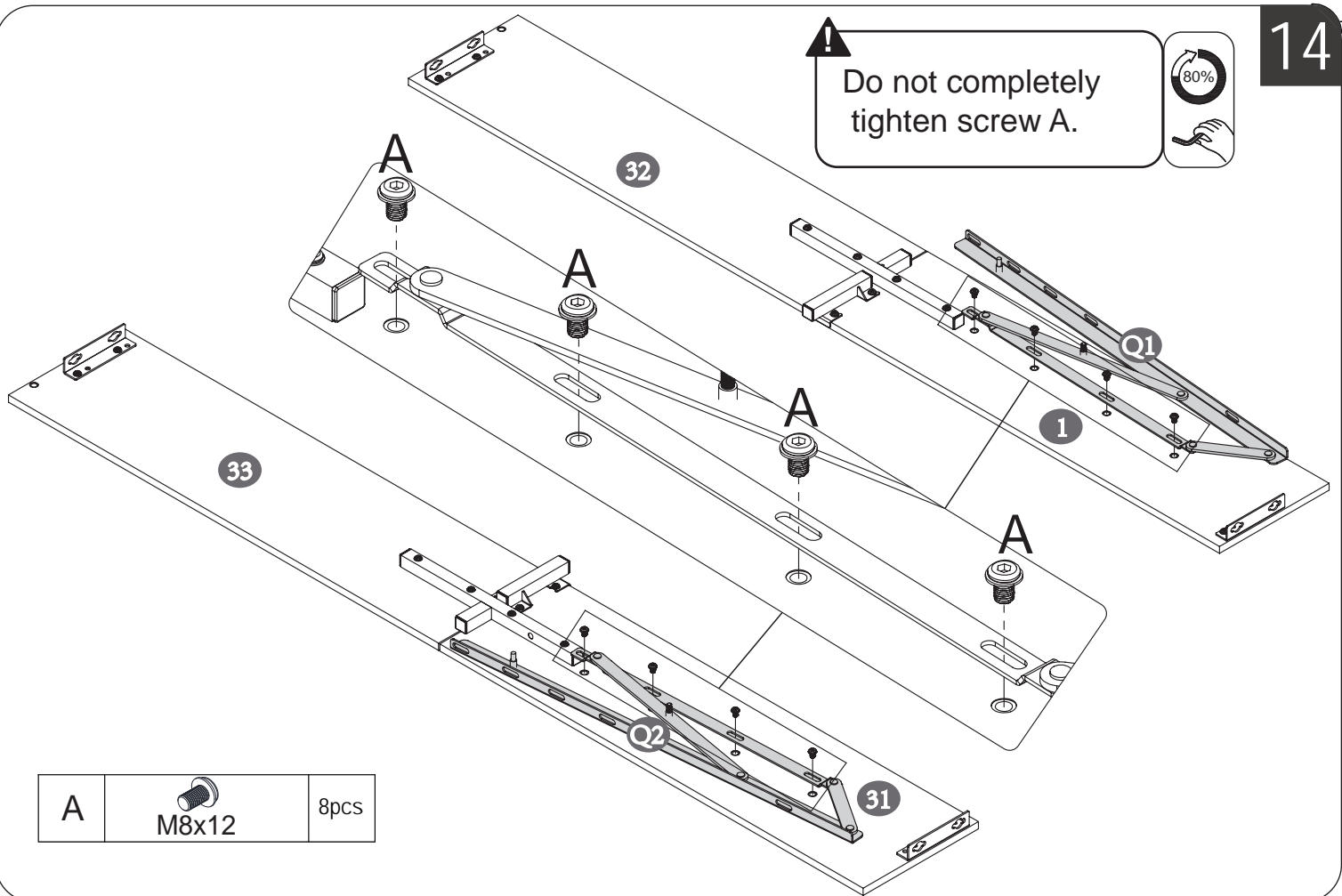

# ASSEMBLY INSTRUCTIONS

15

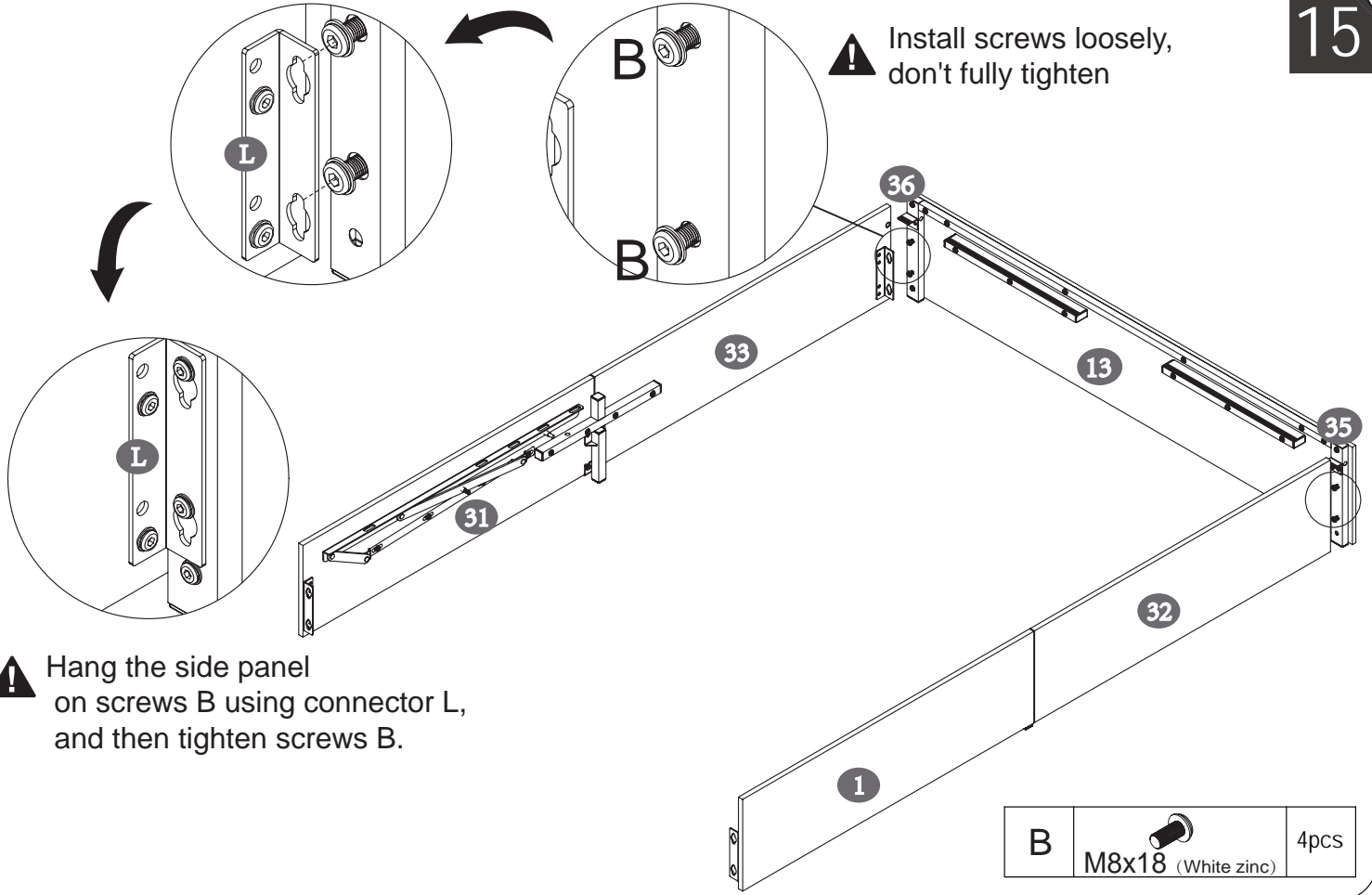

16

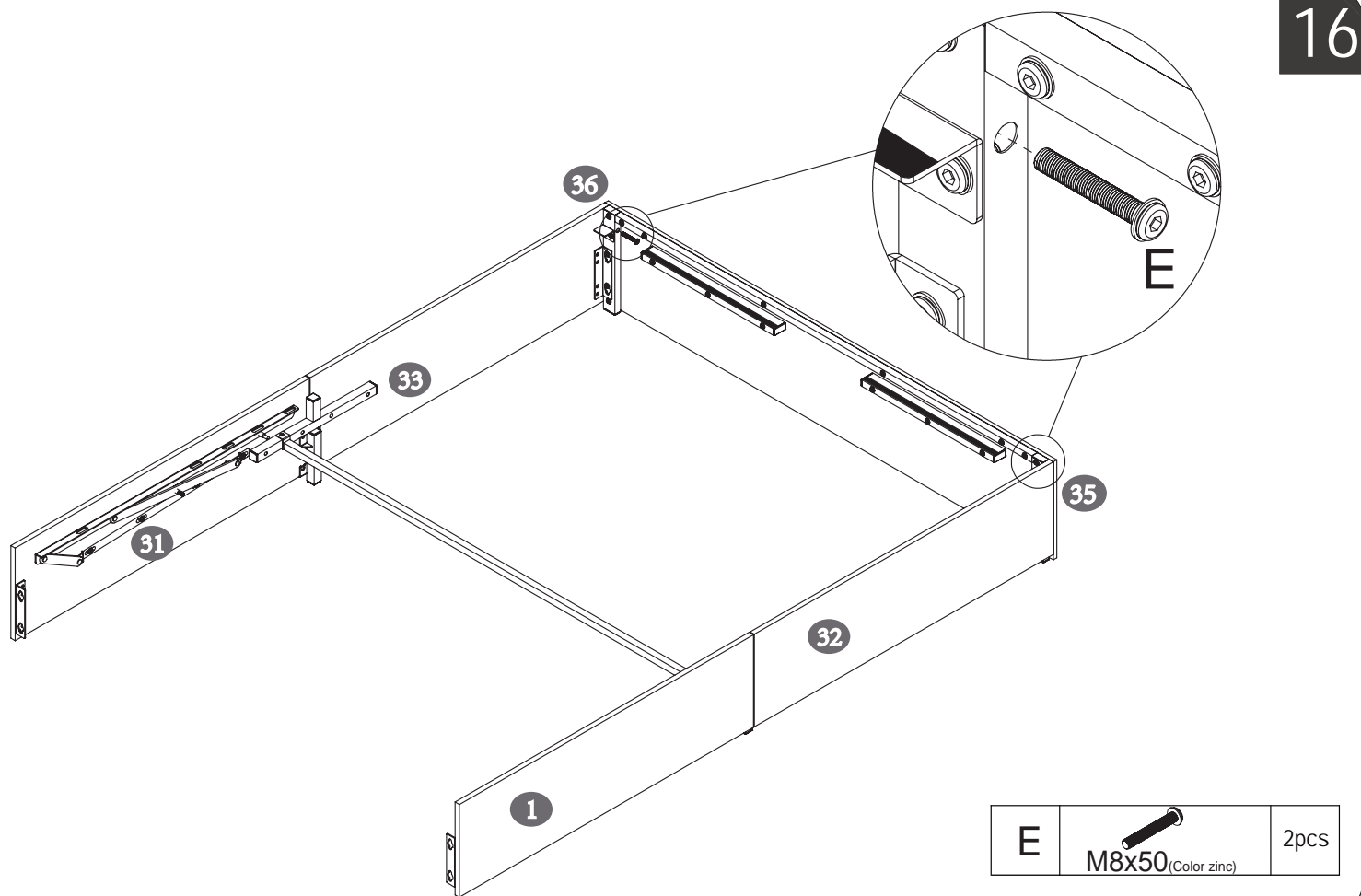

# ASSEMBLY INSTRUCTIONS

17

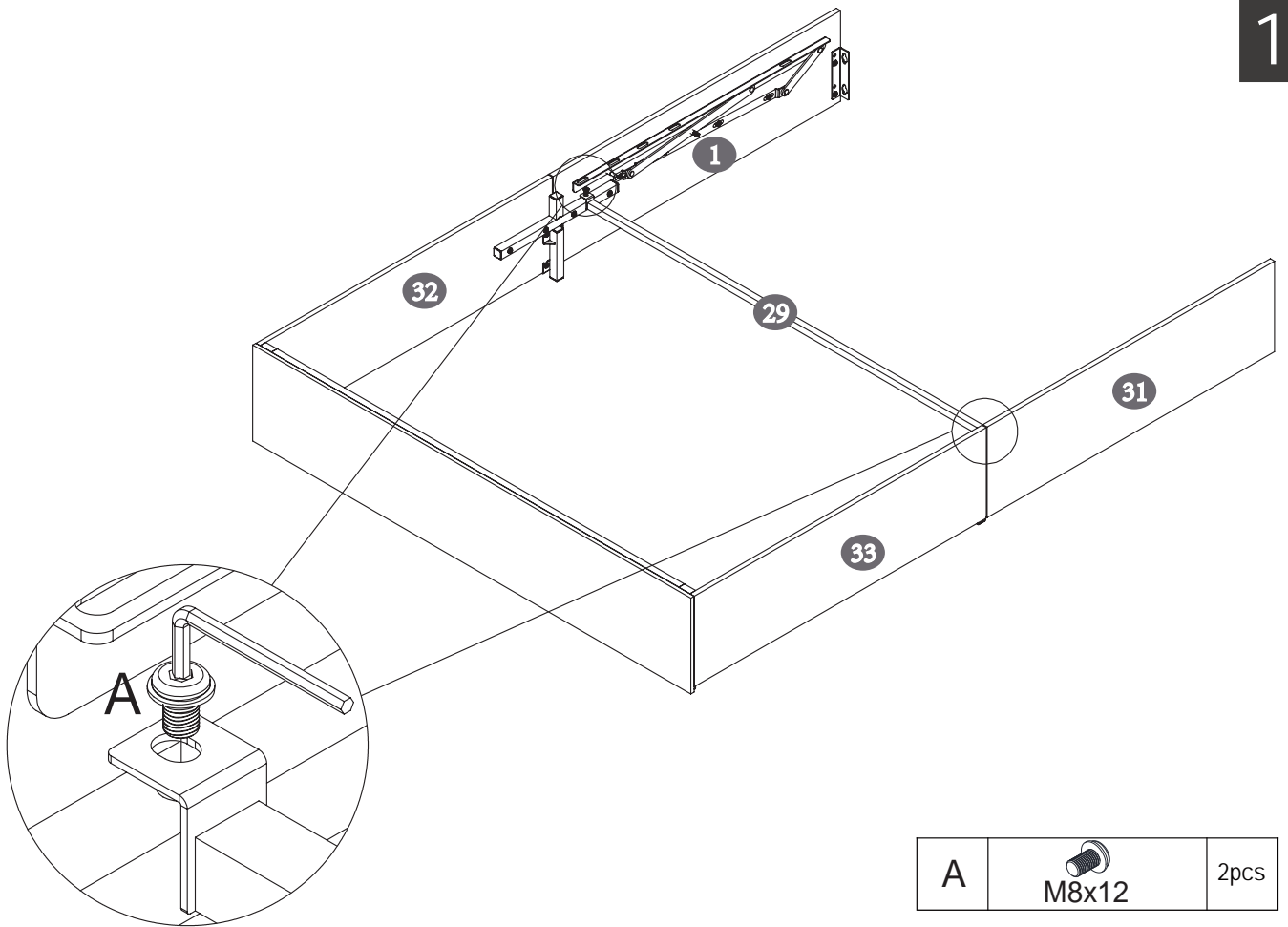

A	 M8x12	2pcs
---	--	------

18

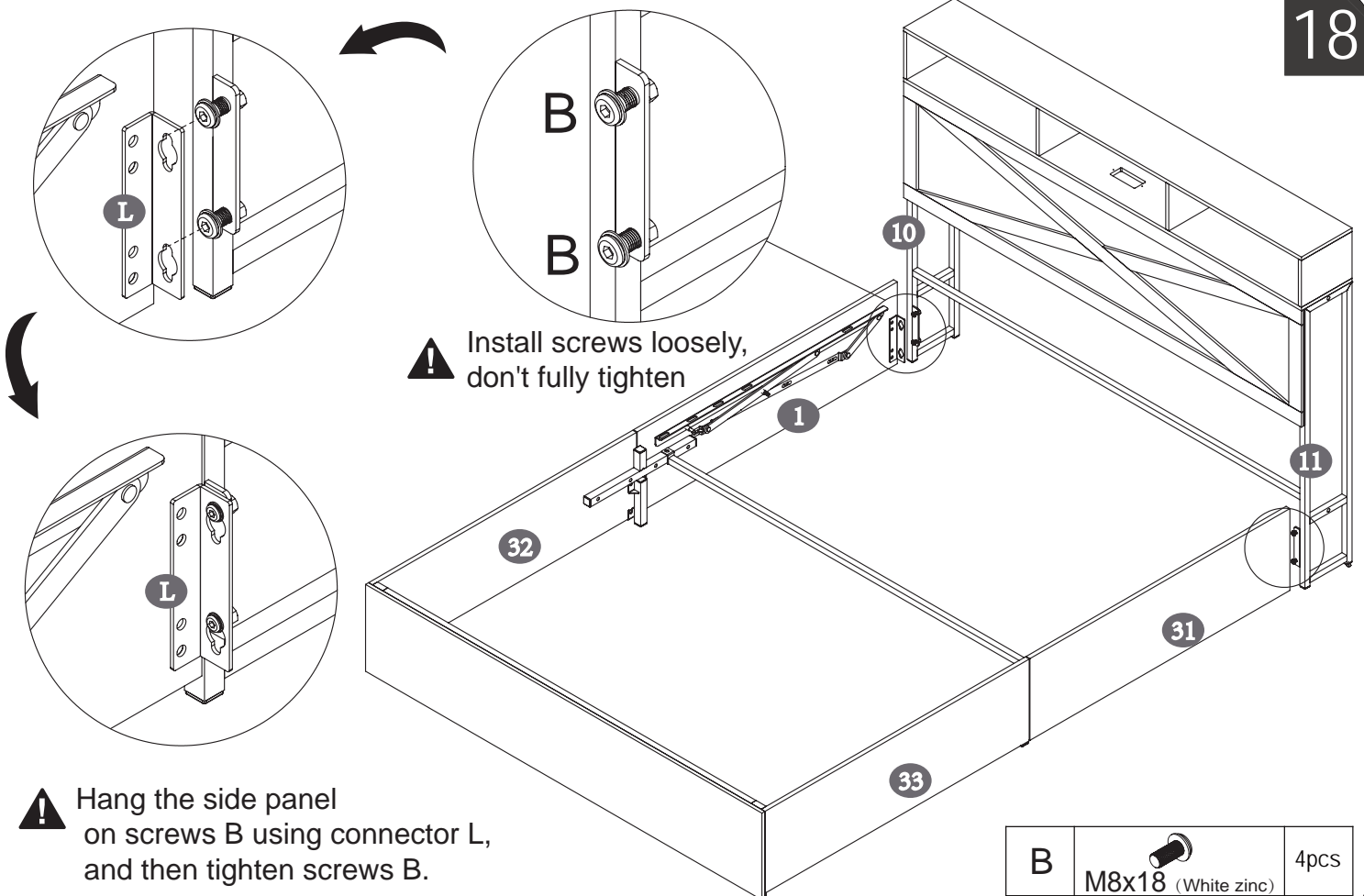

**!** Install screws loosely, don't fully tighten

**!** Hang the side panel on screws B using connector L, and then tighten screws B.

B	 M8x18 (White zinc)	4pcs
---	---	------



2X

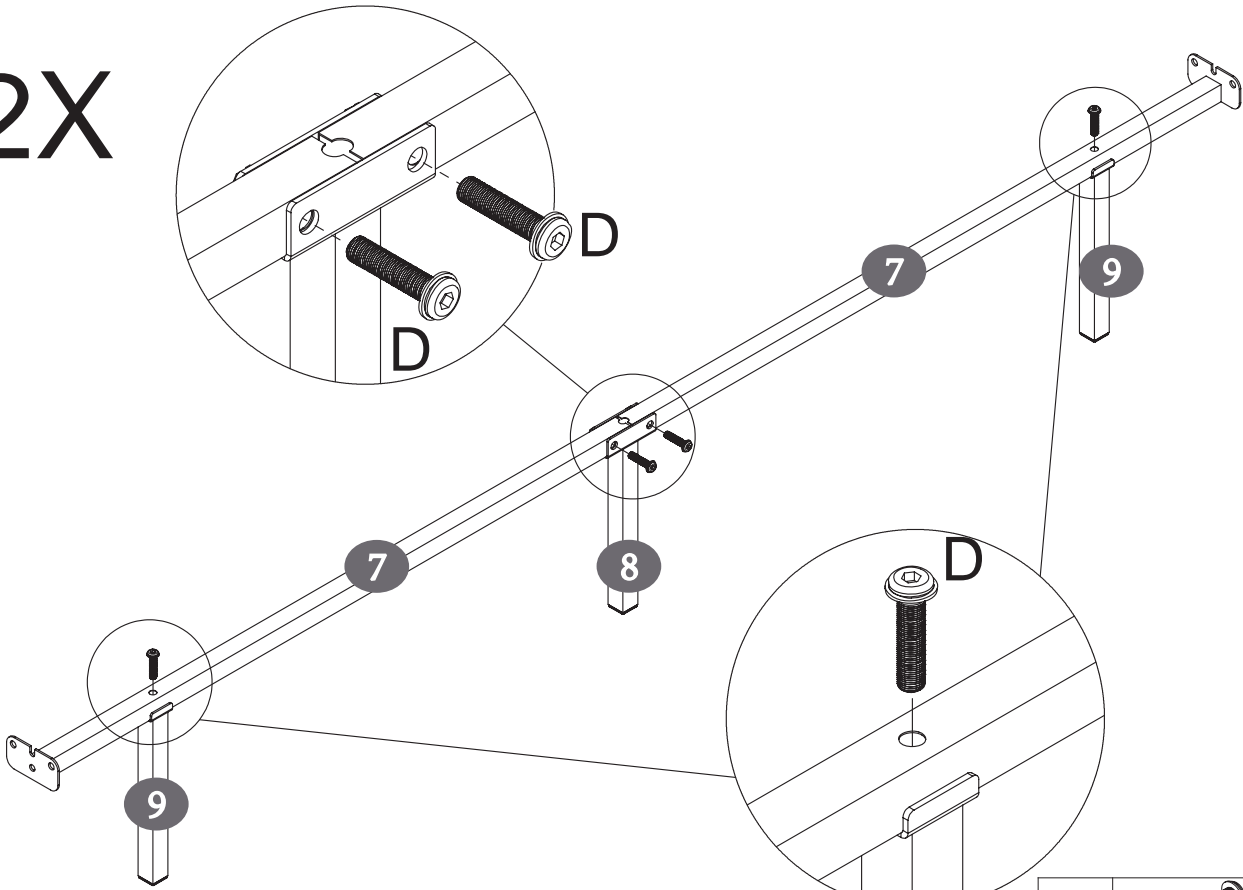

D		8 pcs
---	---	-------

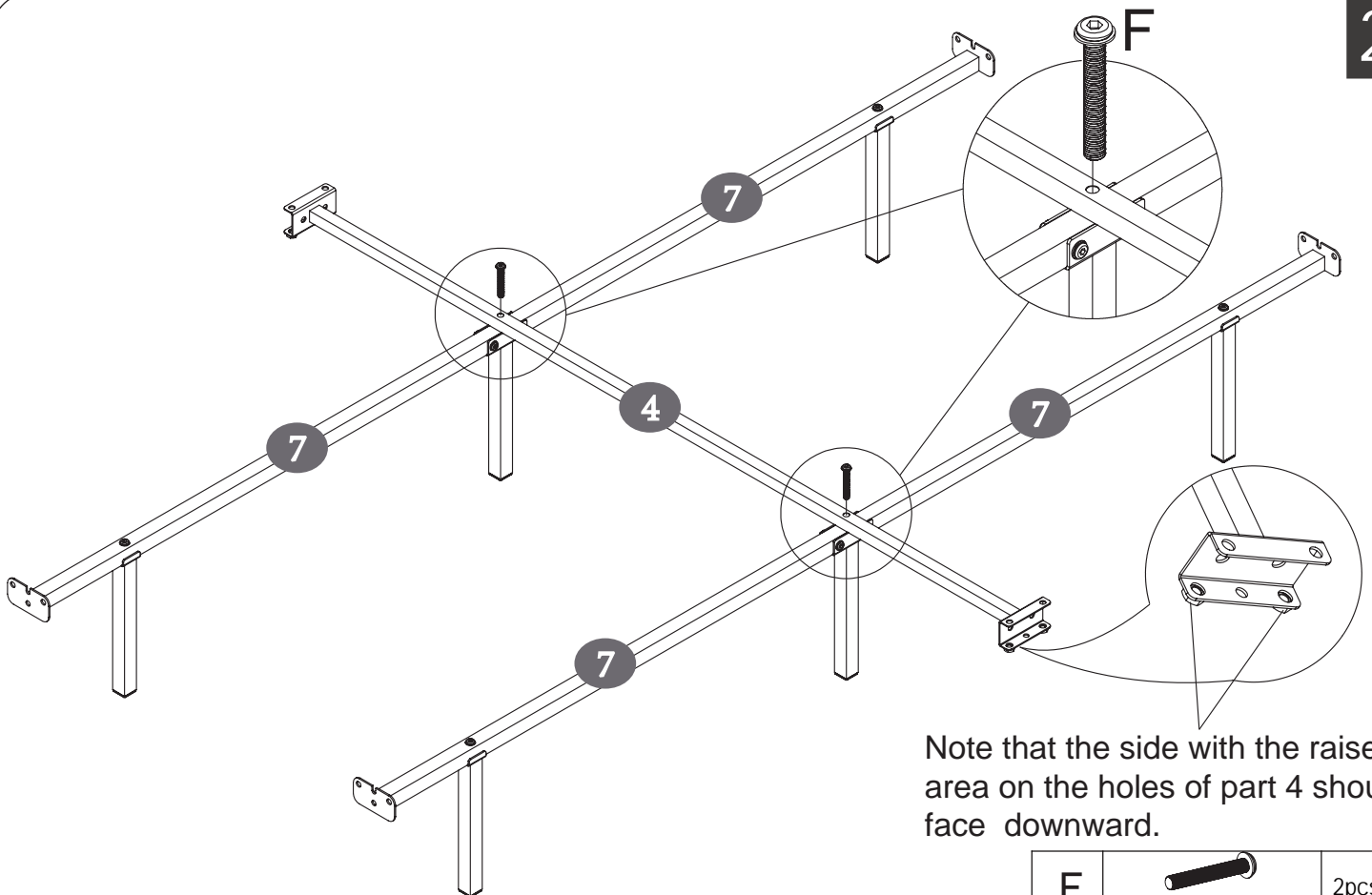

Note that the side with the raised area on the holes of part 4 should face downward.

F		2 pcs
---	---	-------

21

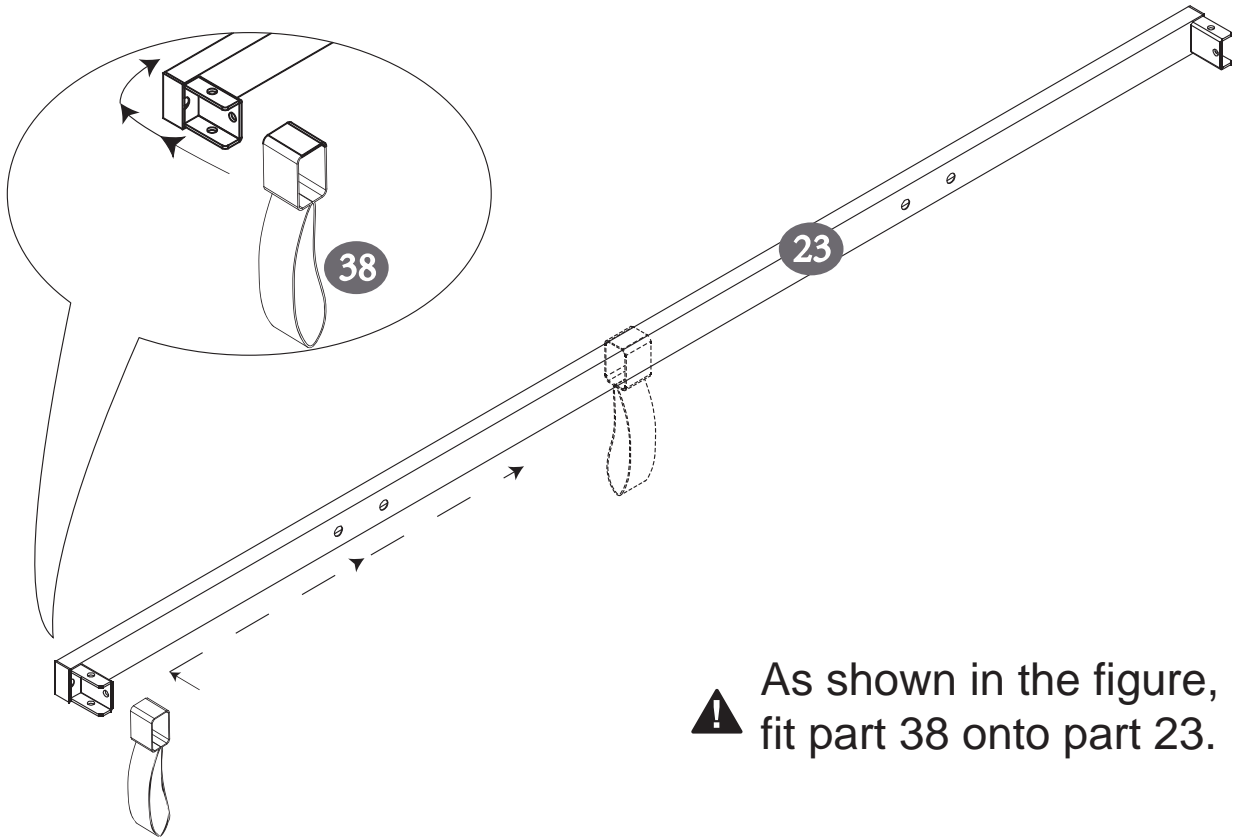

**!** As shown in the figure, fit part 38 onto part 23.

22

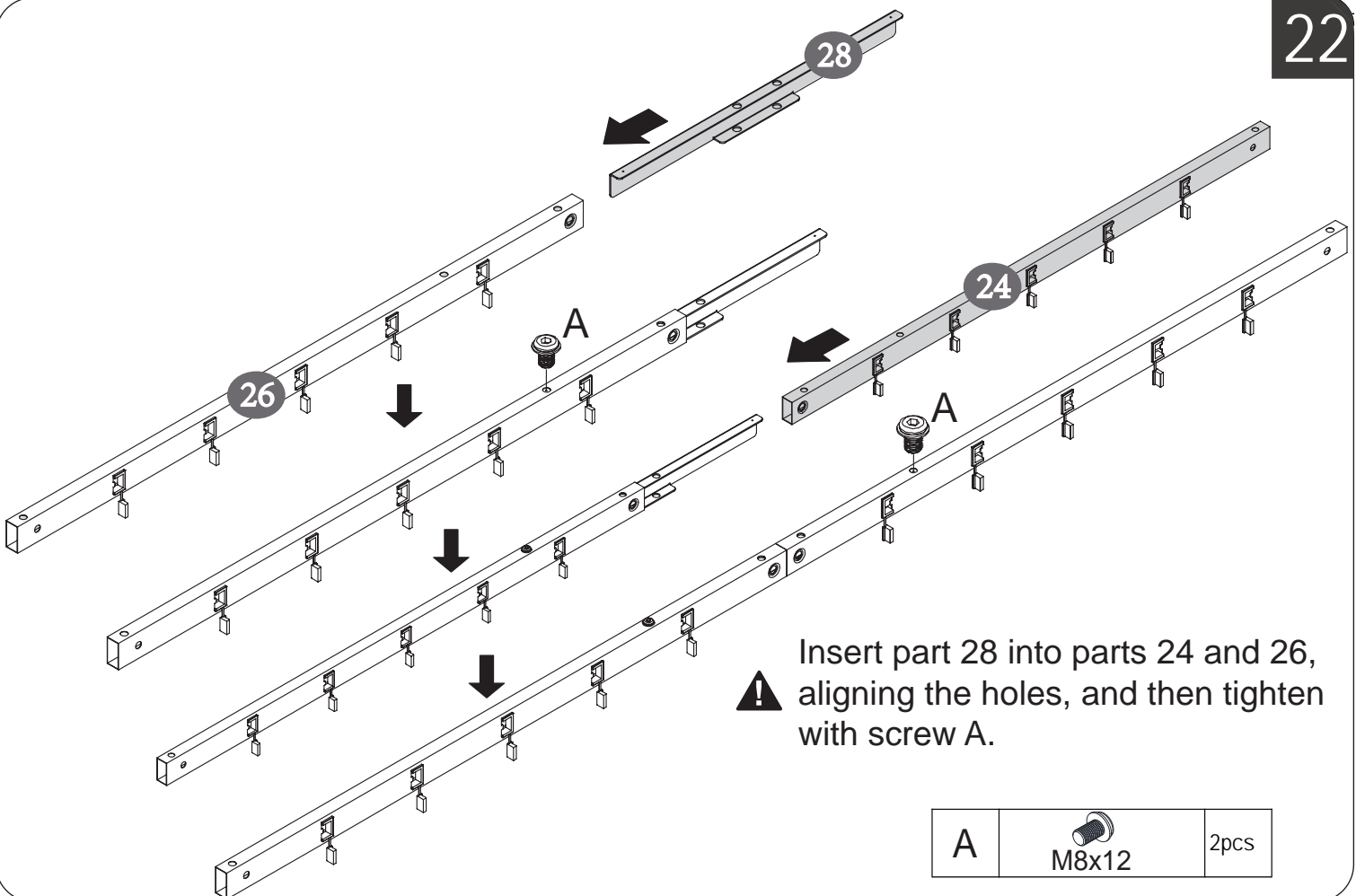

**!** Insert part 28 into parts 24 and 26, aligning the holes, and then tighten with screw A.

A	 M8x12	2pcs
---	---	------

# ASSEMBLY INSTRUCTIONS

23

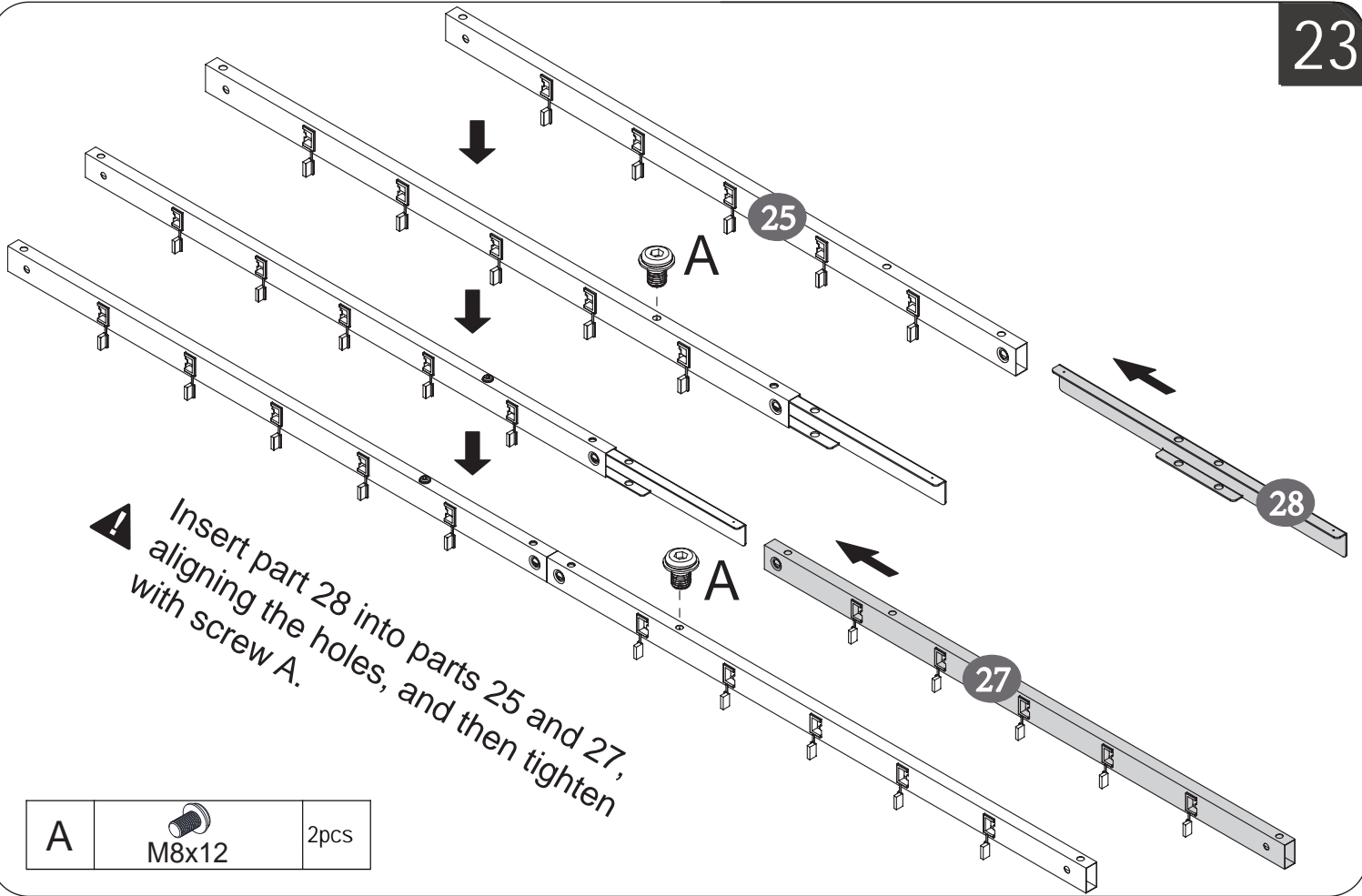

A	 M8x12	2pcs
---	---	------

24

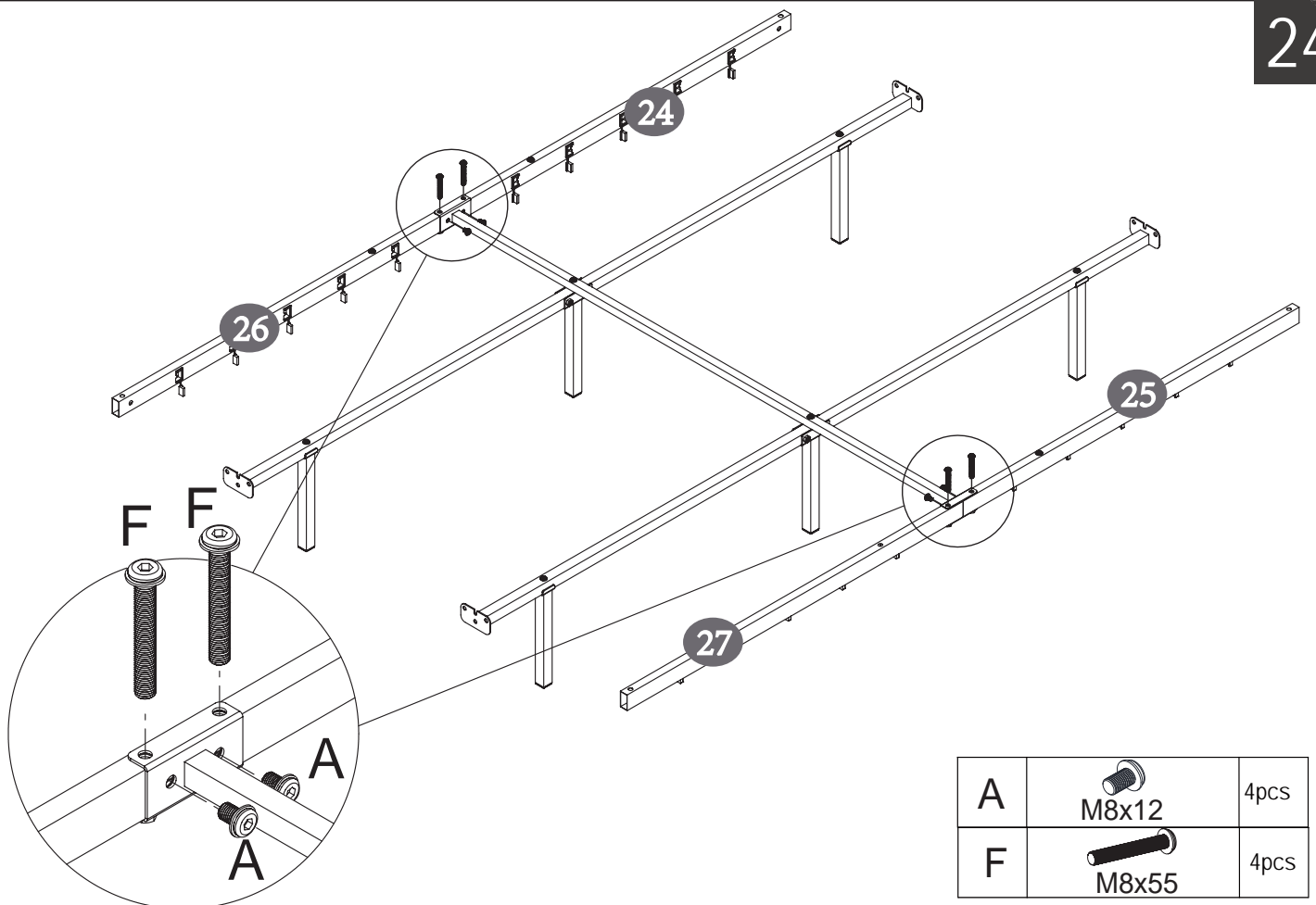

A	 M8x12	4pcs
F	 M8x55	4pcs

# ASSEMBLY INSTRUCTIONS

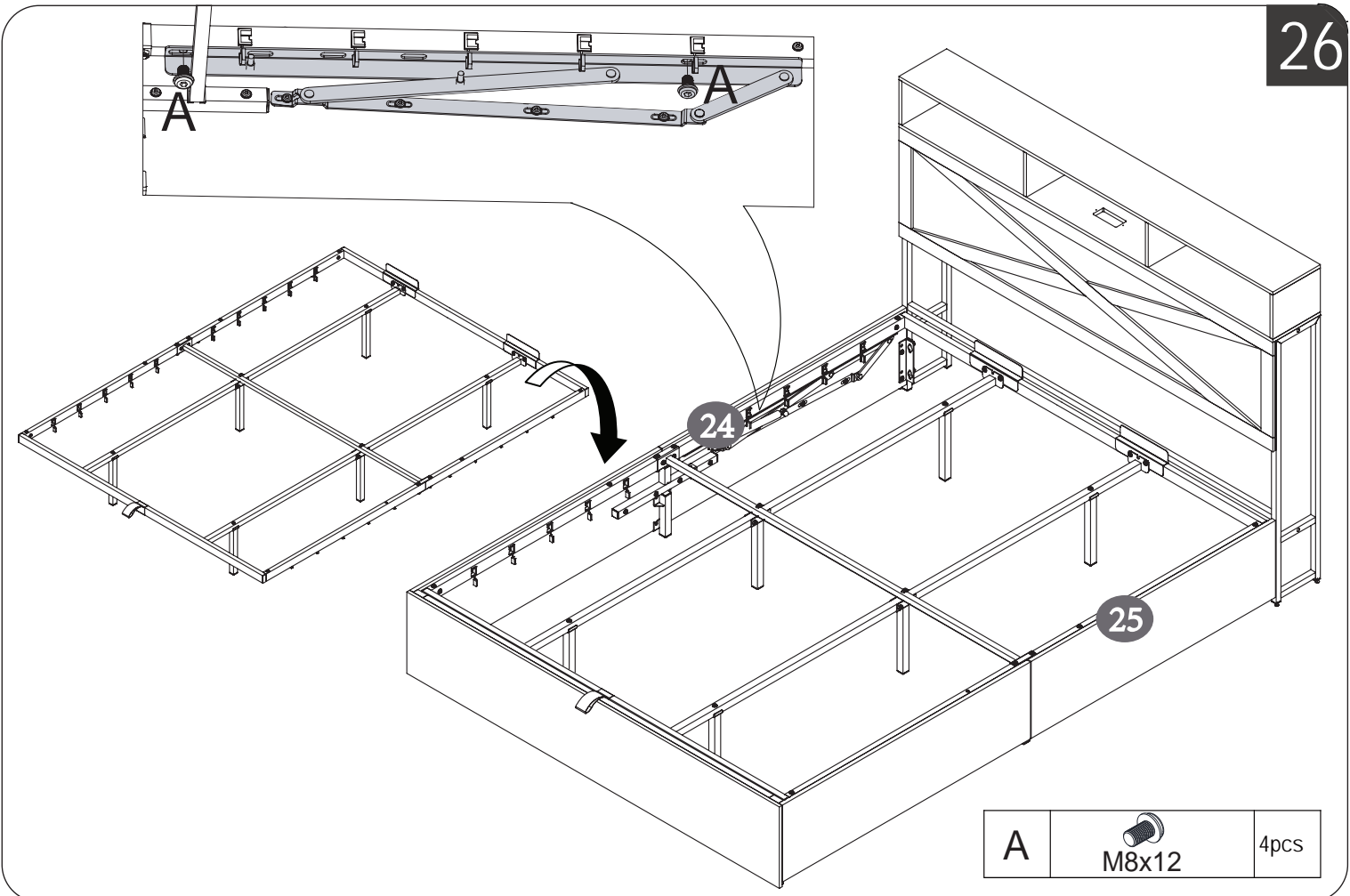
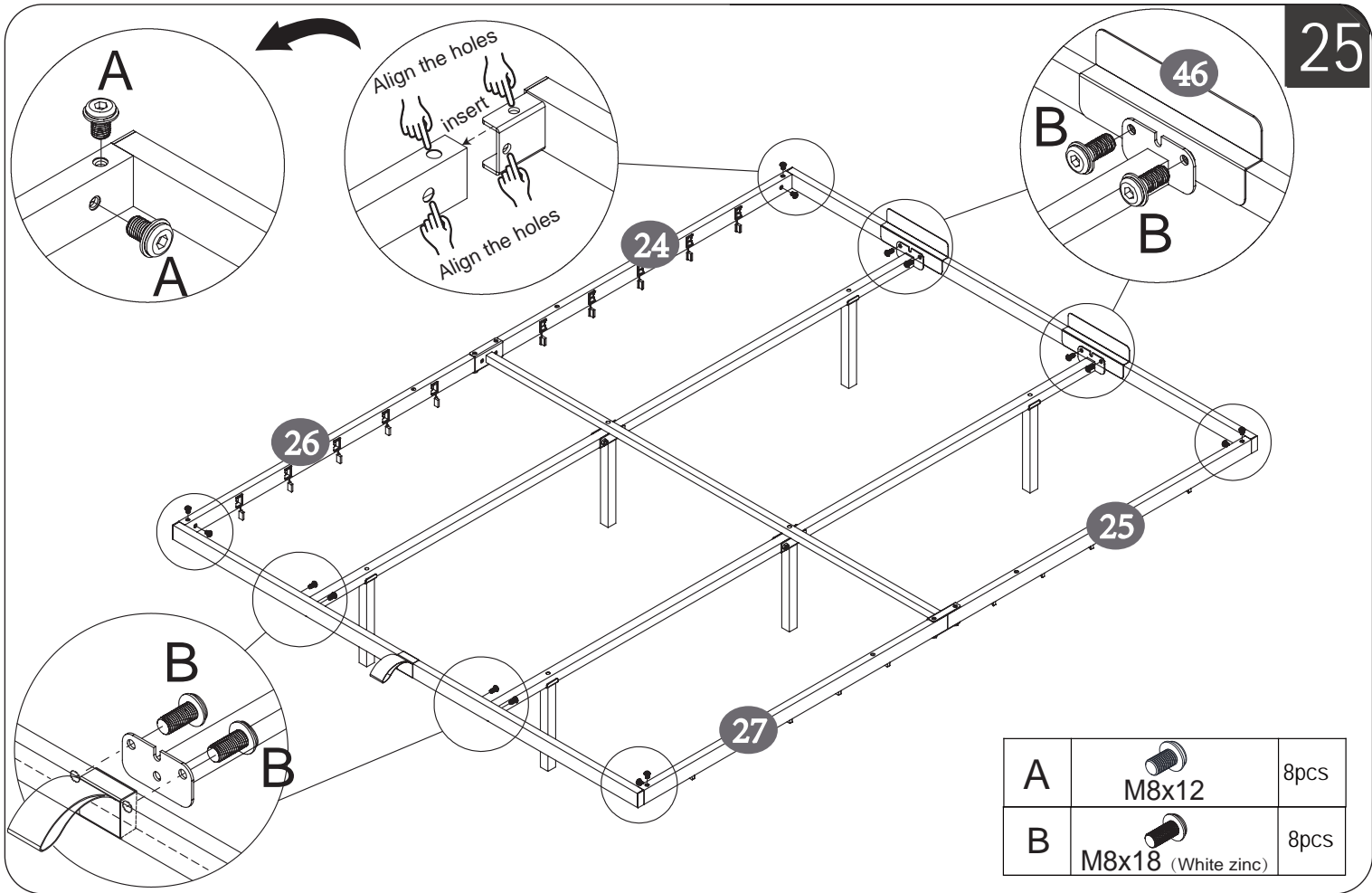

**!** Lift the frame and install part Q3.

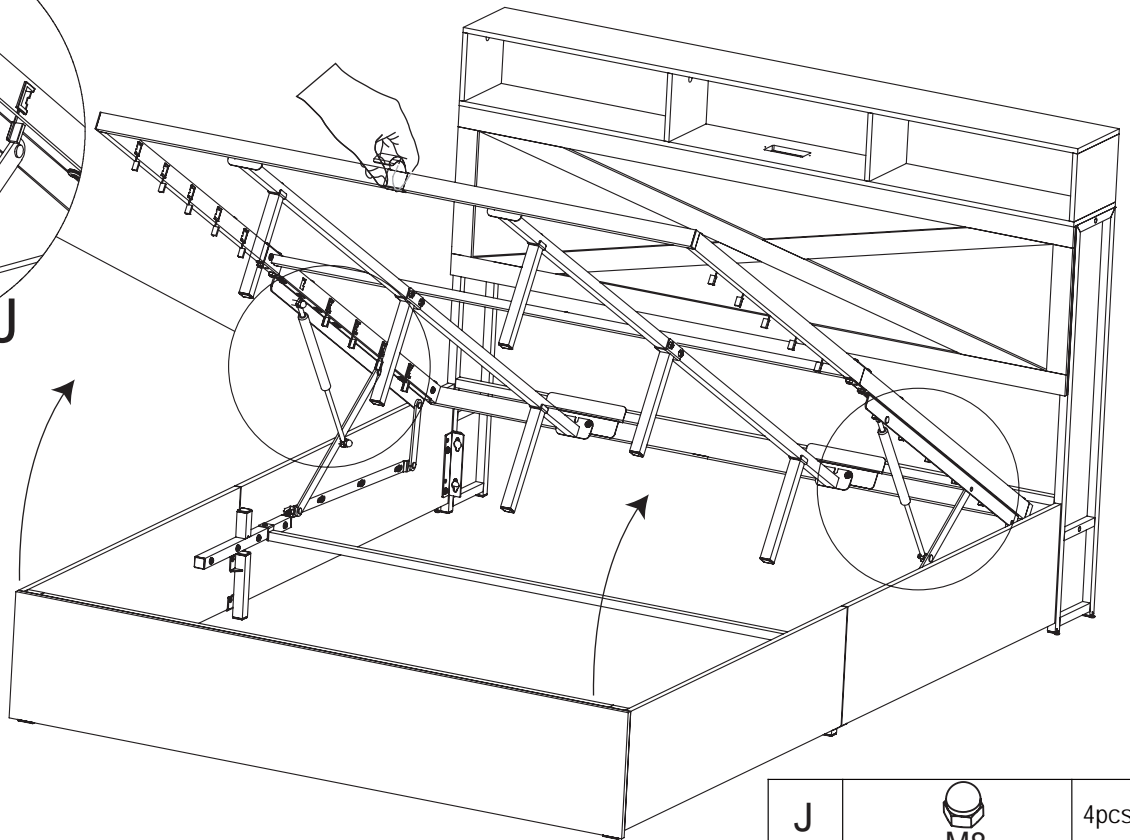
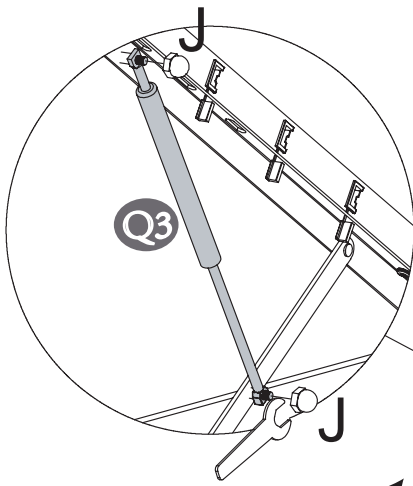

J	 M8	4pcs
---	---	------

**!** Please push the fastener block c firmly to ensure a secure installation.

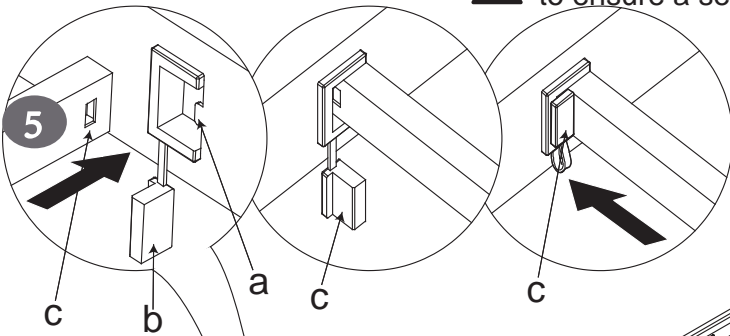

**!** Ensure that the raised part a on the mounting openings is inserted into the socket b on part 5, and then push in the fastener block c to secure it.

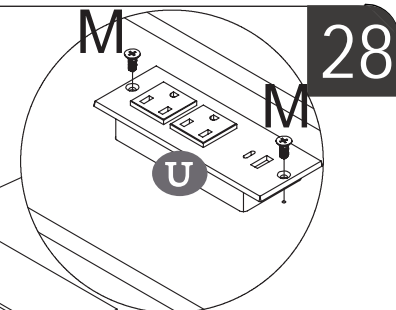
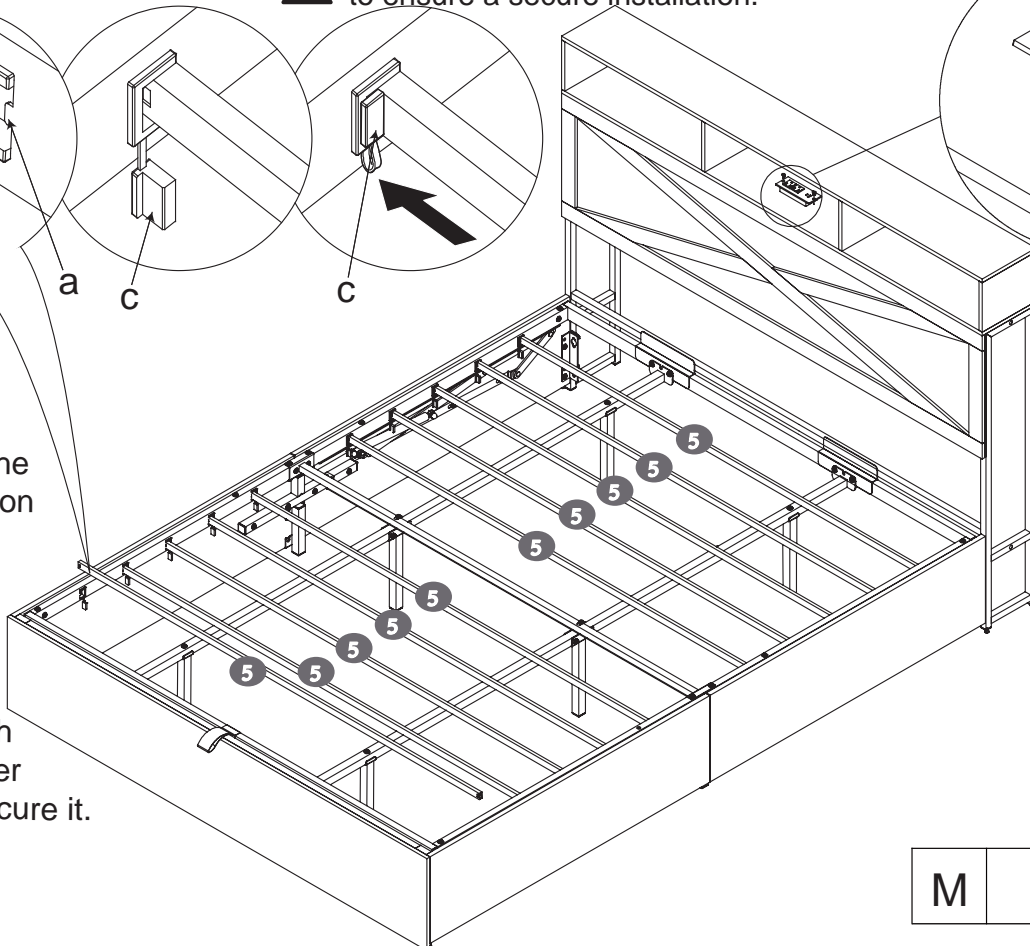

M	 ST4.2x12	2pcs
---	---	------

2X

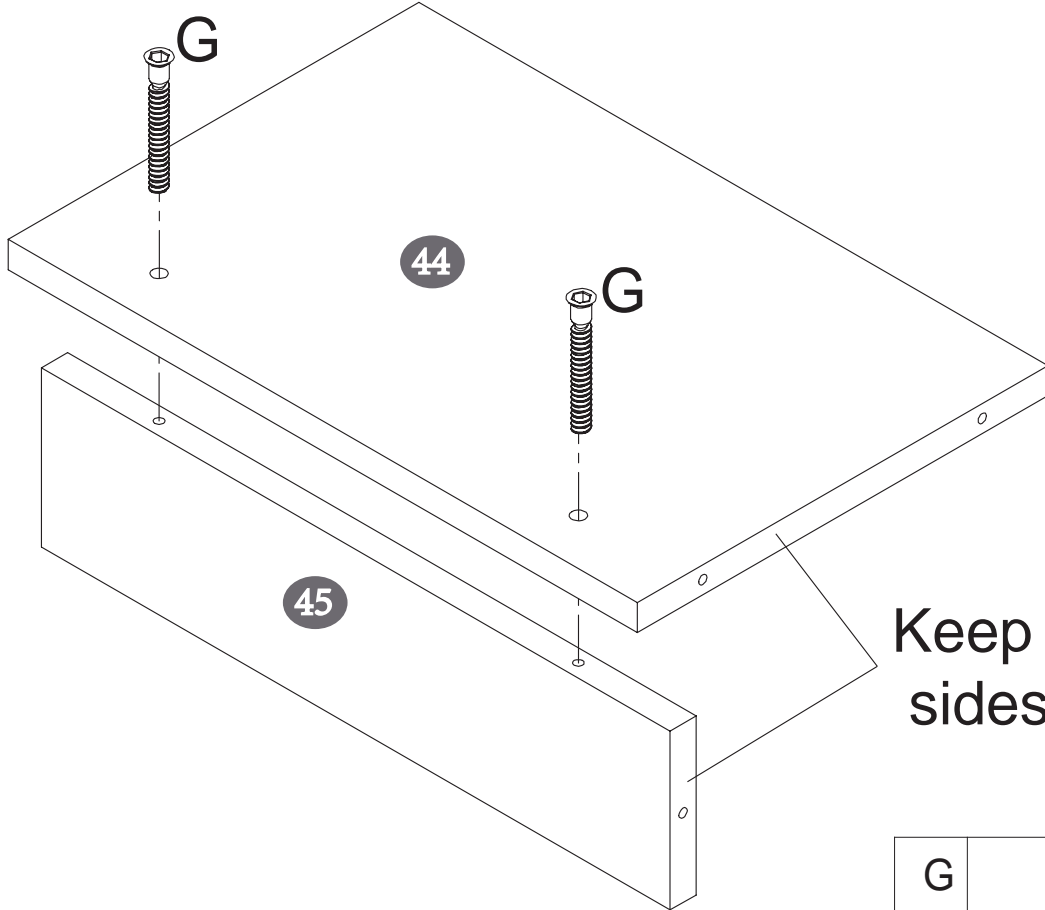

Keep the two sides flush

G	 M5x40	4pcs
---	--	------

2X

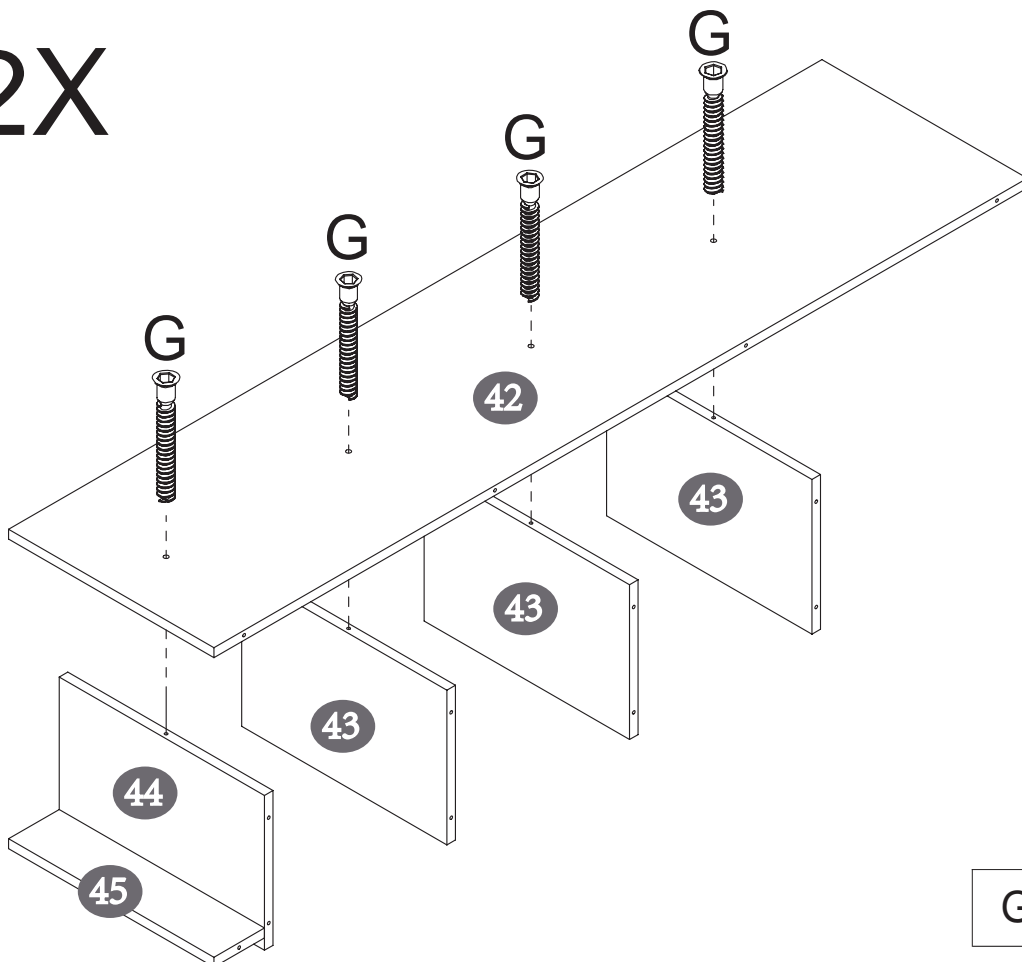

G	 M5x40	8pcs
---	--	------

31

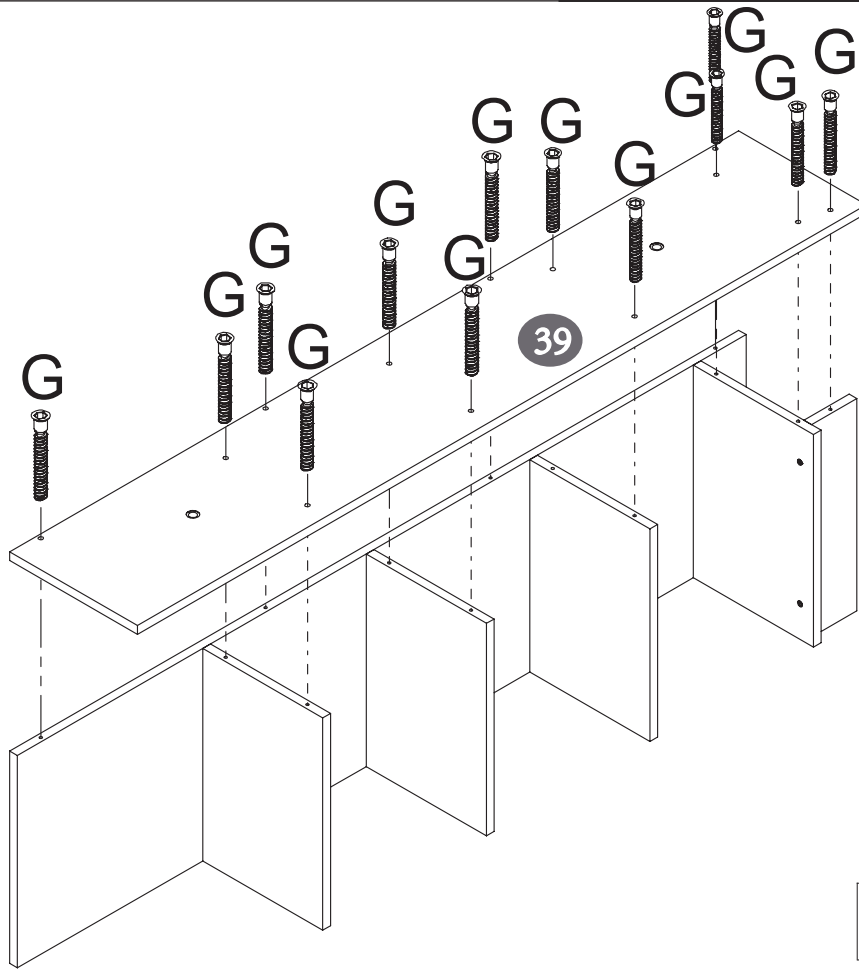

G		13pcs
---	---	-------

32

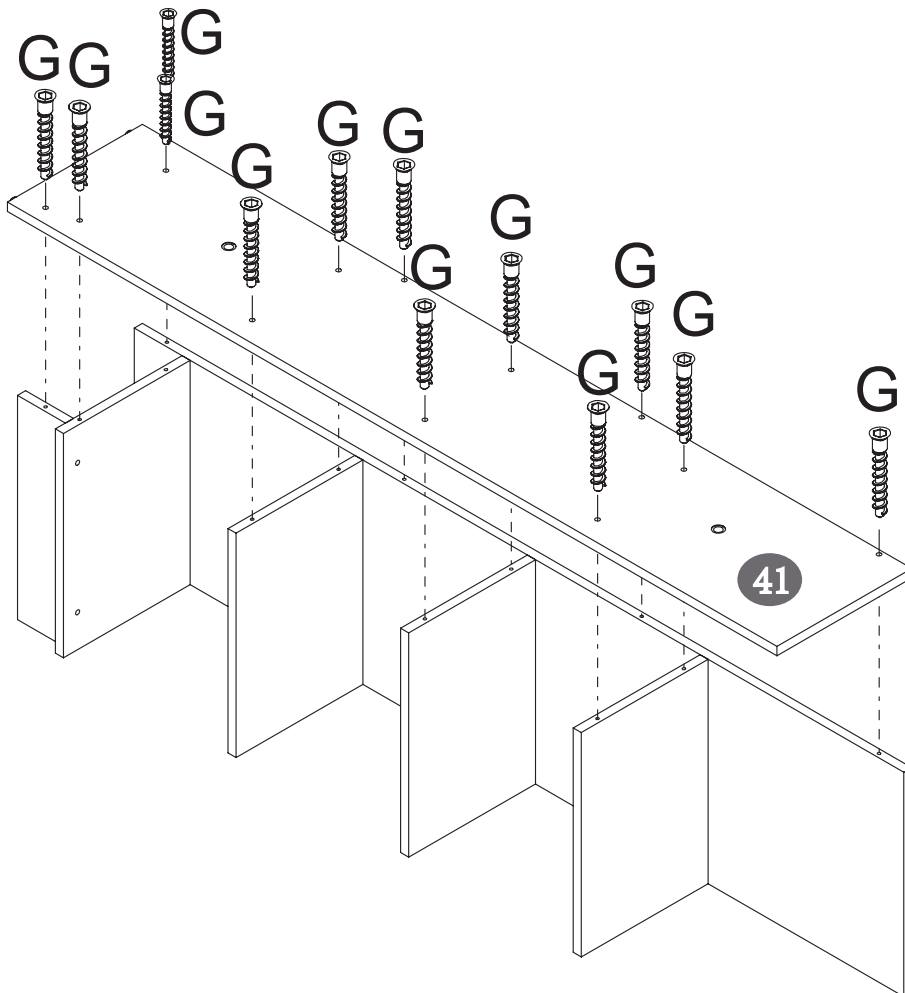

G		13pcs
---	---	-------

# ASSEMBLY INSTRUCTIONS

33

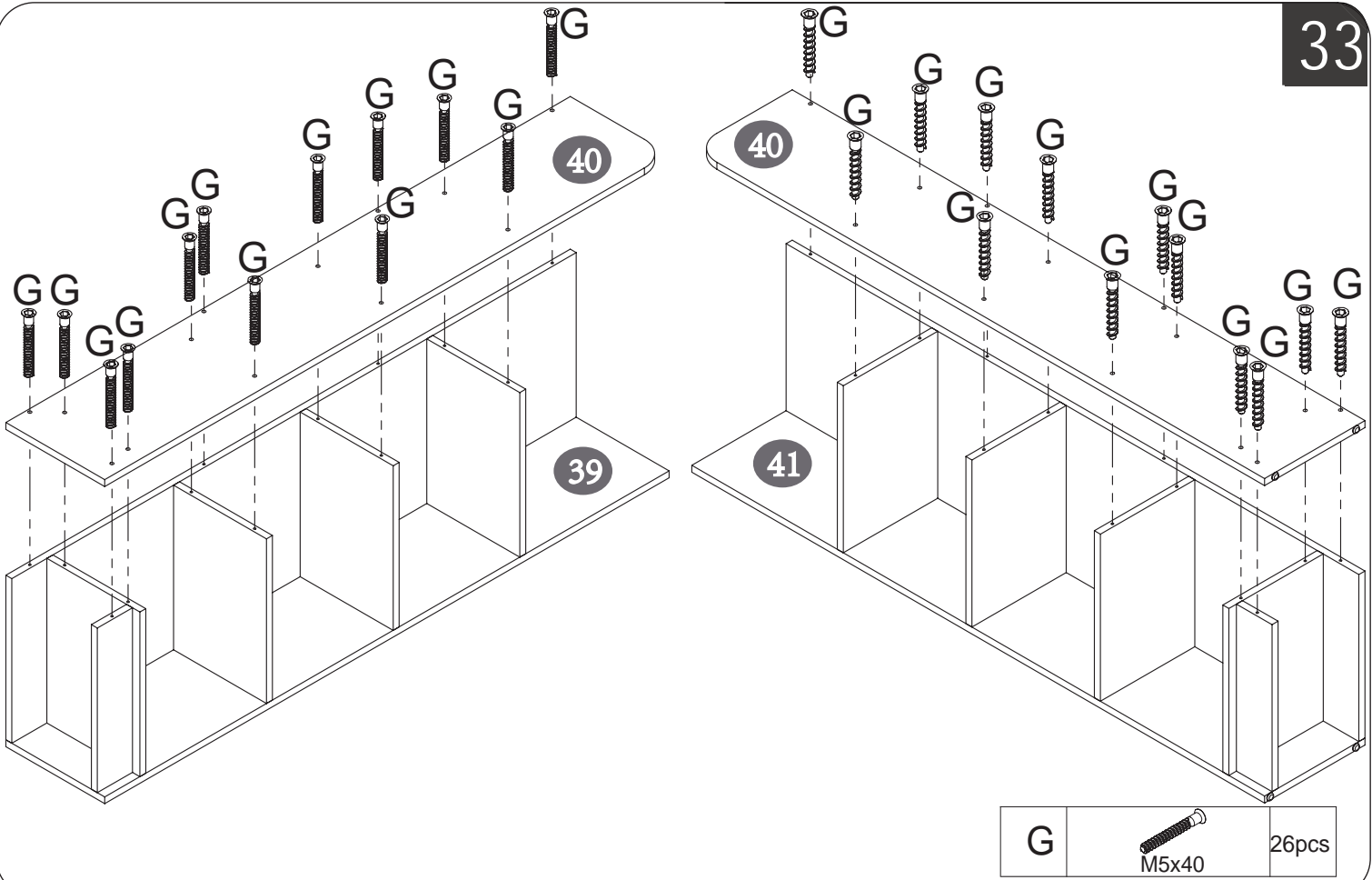

G		26pcs
	M5x40	

34

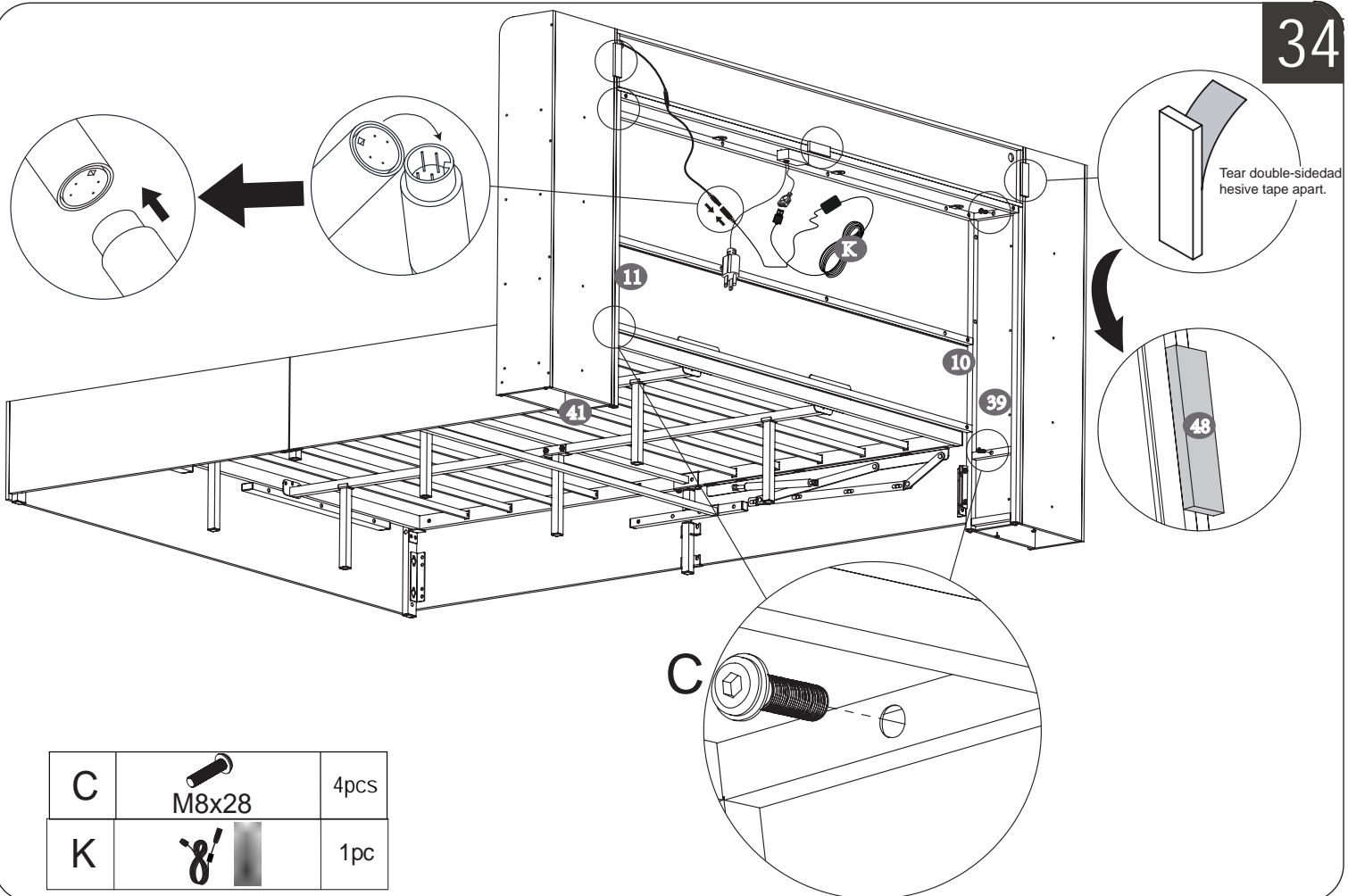

C		4pcs
K		1pc



If you do not wish to use the storage cabinets on either side of the headboard, you can remove them by unscrewing the screws.

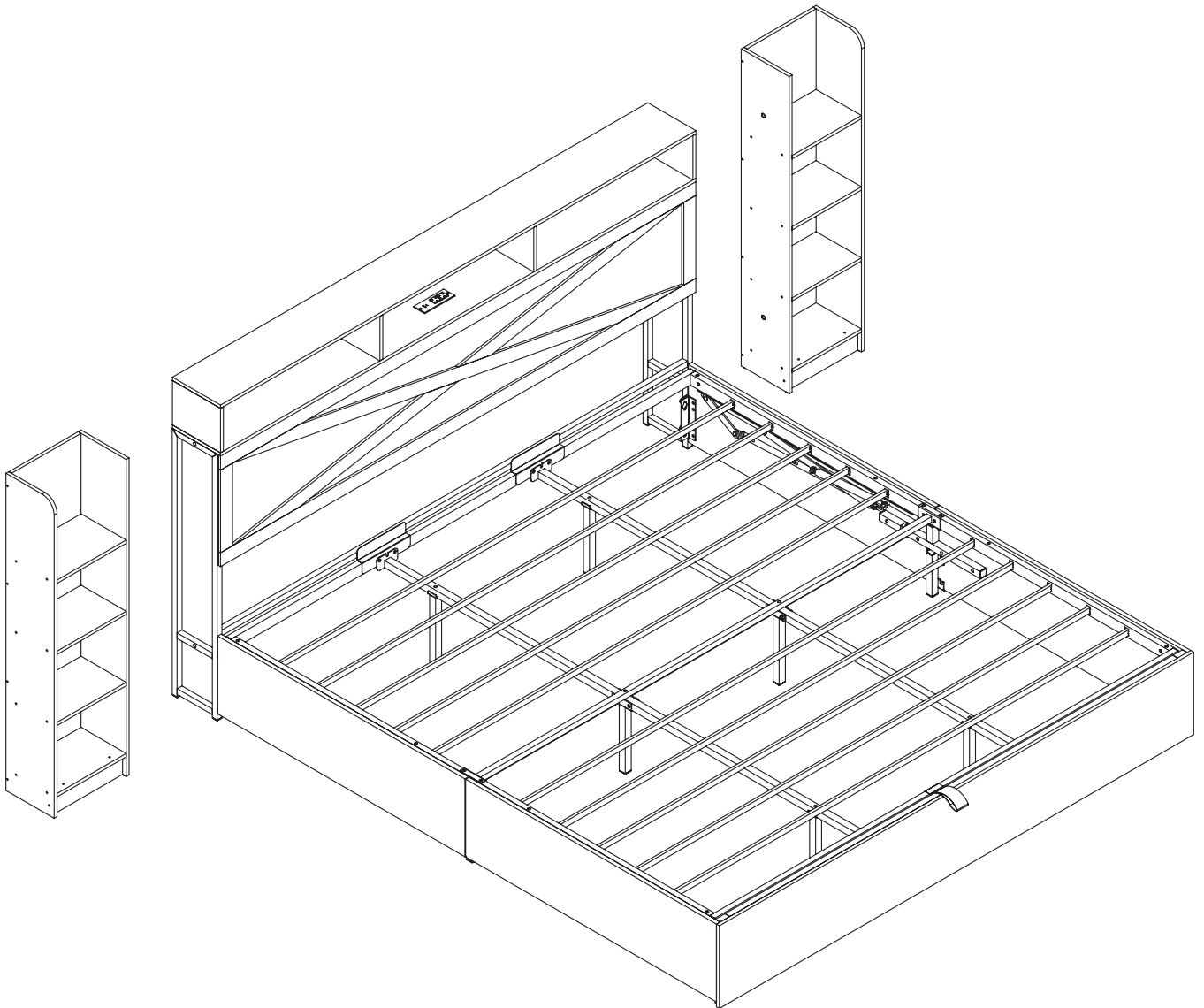

⚠ Make sure the assembly holes are aligned.  
TIGHTEN ALL THE SCREWS COMPLETELY.



Installation Complete

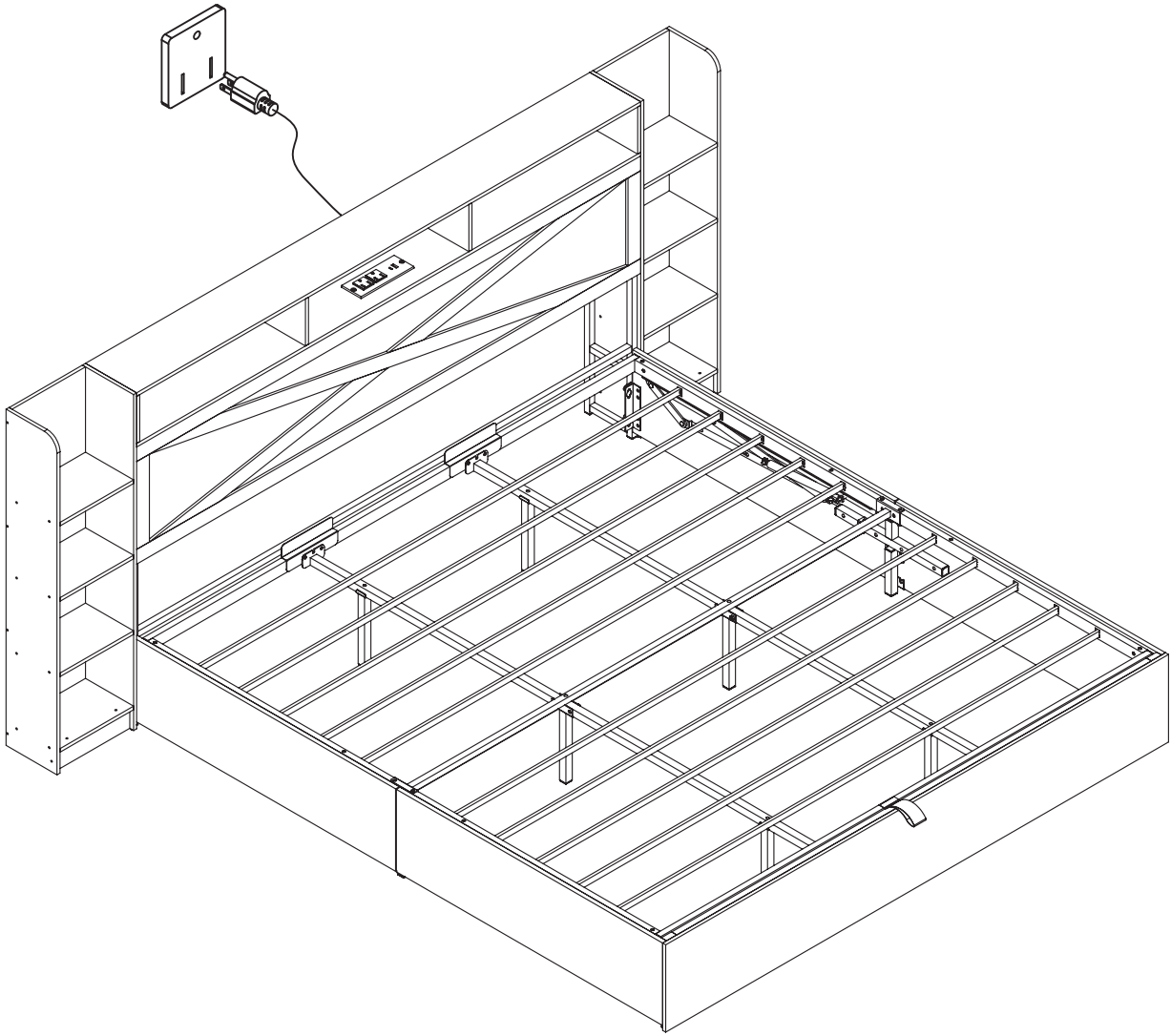

⚠ Make sure the assembly holes are aligned.  
TIGHTEN ALL THE SCREWS COMPLETELY.



Installation Complete